

BULTRITE™ **HANDLERS & ATTACHMENTS**

Scrap Grapples

Four Tine Orange Peel

Builtrite, 4-Tine Orange Peel Grapples are designed with the professional scrap processor in mind to provide maximum durability and low maintenance, reducing your downtime. Key features include:

- Low upper head profile allows more vertical reach for higher stacking.
- Wide openings allow for cleaning out corners of truck bodies and rail cars.
- High tensile steel used throughout. AR 500, wear resistant steel used on all spade tips.
- Oversized, hardened cylinder and pivot pins with bushings.
- Feed lines are directed upward in combination with a hose protection shield.
- High pressure cylinders.
- Bolt-on cylinder shrouds for maximum protection and ease of maintenance.
- 360° continuous rotation, with heavy duty motor, bearing and hydraulic collector (swivel). Motor does not require a case drain line.
- Easily accessible, yet well protected grease zerks.
- Made in U.S.A.

Options Include:

- Rigid or free spinning rotation.
- 3 spade configurations available: Narrow, Mid and Full Spades.

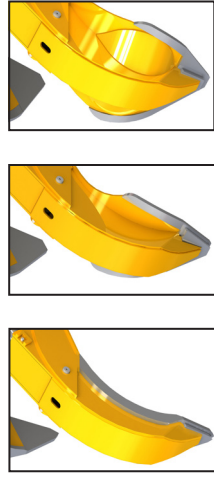

If you're looking for the toughest, most durable grapple on the market, look no further...make it a **Builtrite**.

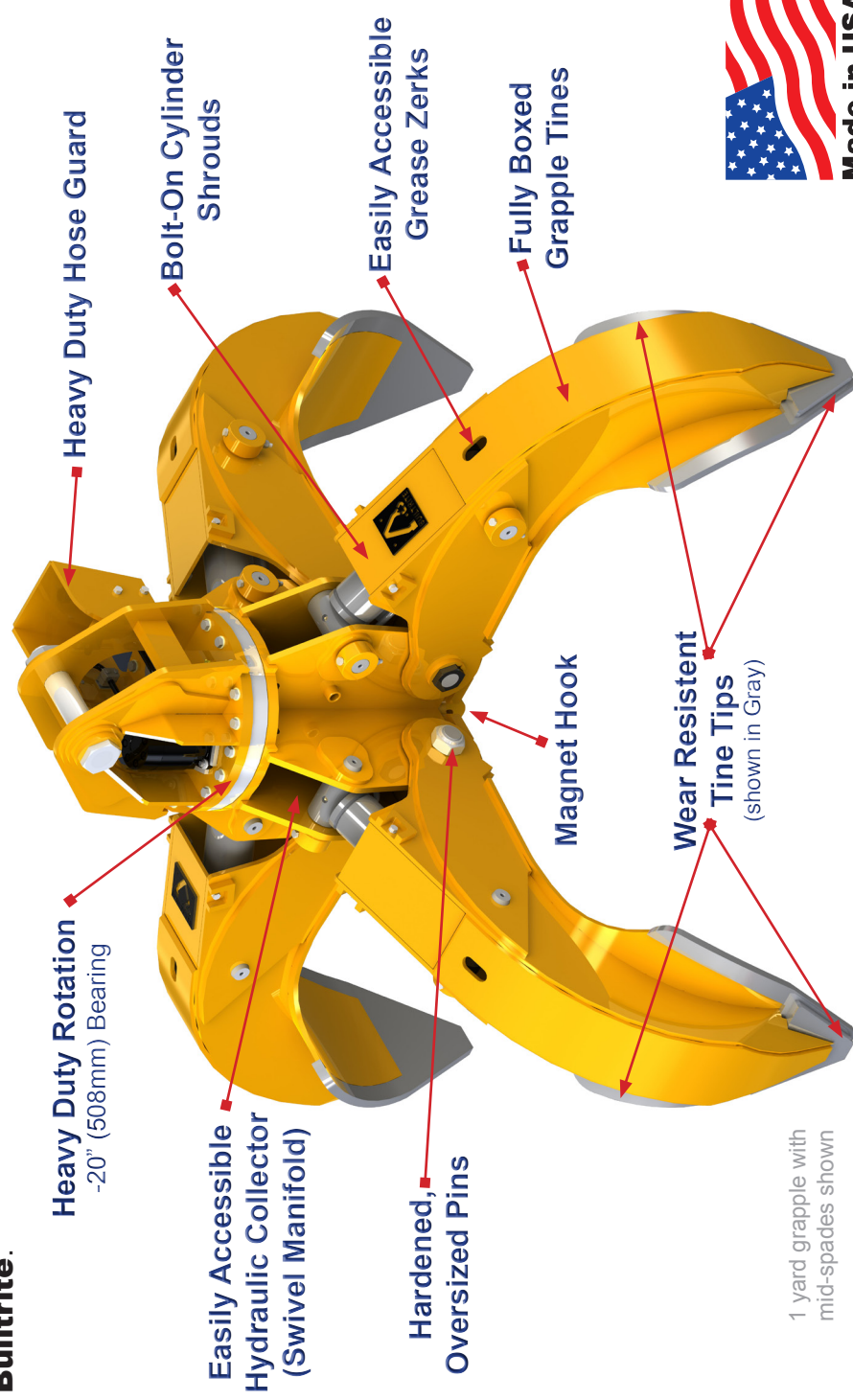

1 yard grapple with mid-spades shown



Builtrite 4TSG-100, Orange Peel Grapple Specifications

Model	Volume @ Full Close		Volume @ 60% Close (approx.)		Weight		Opening (A)		Overall Width (B)		Depth @ Full Open (C)		Height @ Full Open (D)		Inside Width @ Full Close (E)		Outside Width @ Full Close (F)		Height @ Full Close (G)	
	Yd. ³	M ³	Yd. ³	M ³	Lbs.	Kg.	in.	mm	in.	mm	in.	mm	in.	mm	in.	mm	in.	mm	in.	mm
4TSG-25	.25	.2	.375	.3	1,300	590	54	1,372	60	1,524	20.5	521	52	1,321	23	584	38.5	978	59.5	1,499
4TSG-50	.50	.4	.75	.6	3,150	1,429	75	1,905	88	2,235	23	584	68	1,727	33	838	58	1,473	80	2,032
4TSG-75	.75	.6	1.3	1.0	3,400	1,542	86	2,184	98	2,489	26	660	70	1,778	37.5	953	59.5	1,511	79	2,007
4TSG-100	1.0	.8	1.5	1.15	4,300	1,954	93	2,362	104	2,642	30.5	775	72	1,829	40	1,016	62.25	1,581	89	2,260
4TSG-125	1.25	1.0	1.9	1.5	4,900	2,227	104	2,642	115	2,921	30	762	73.5	1,867	46	1,168	71	1,803	94	2,388
4TSG 150	1.5	1.2	2.25	1.75	5,800	2,631	113	2,870	124	3,150	32.5	826	76	1,930	48	1,219	71.5	1,816	95	2,413
4TSG-200	2.0	1.5	3.0	2.3	6,400	2,909	123	3,124	131	3,327	33	838	78	1,981	53	1,346	78.5	1,994	102.5	2,667

Note: We measure our grapple capacity when the grapple is fully closed, unlike most of our competitors who measure their average payload capacities. For comparison purposes, please refer to the 3rd column to find our average payload capacity.

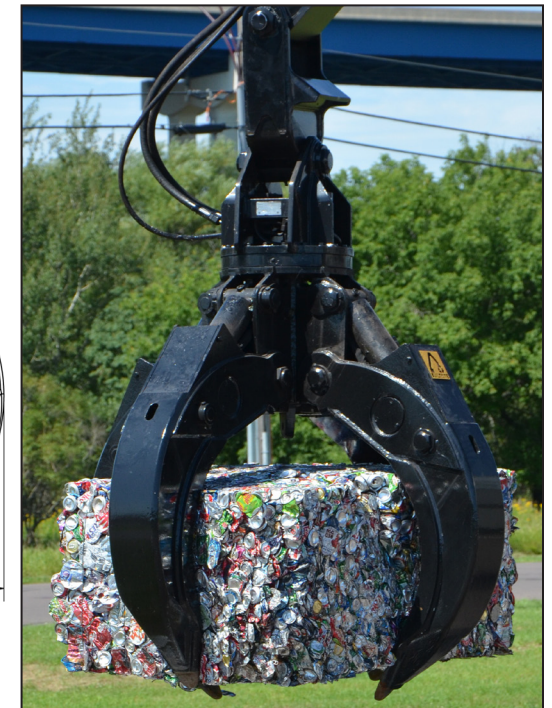
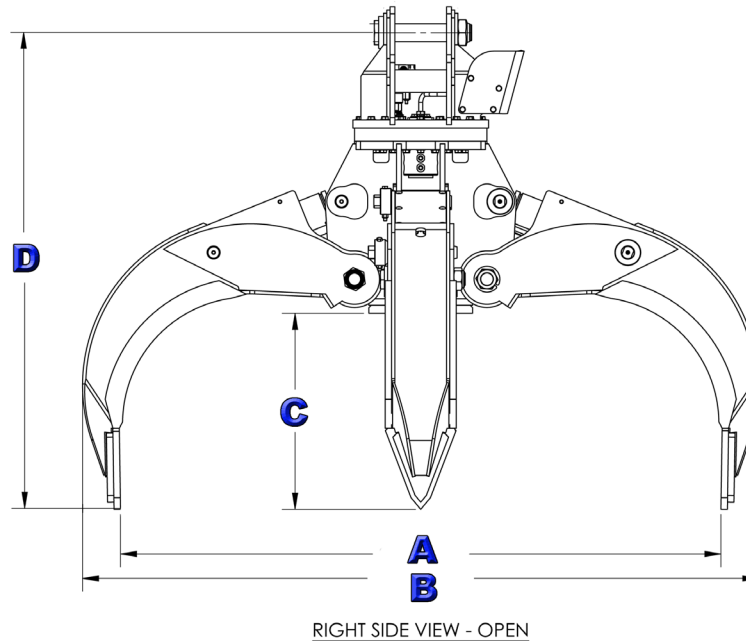
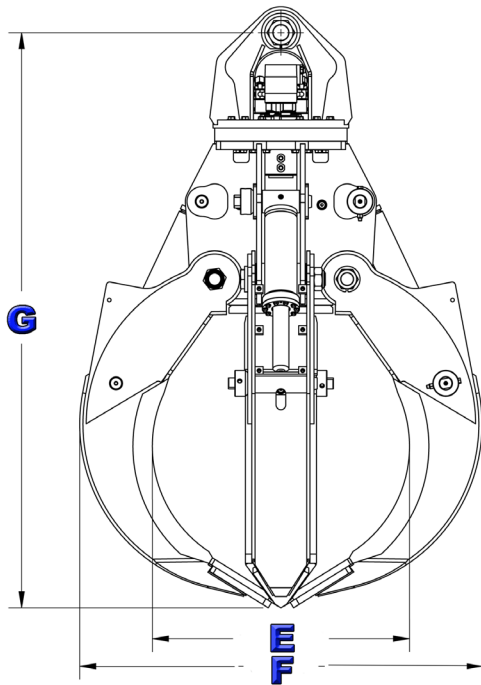

NORTHSHORE MANUFACTURING RESERVES THE RIGHT TO CHANGE SPECIFICATIONS AND PRICES WITHOUT NOTICE IN ORDER TO FOLLOW ITS POLICY OF CONSTANTLY STRIVING TO MANUFACTURE A BETTER PRODUCT WITHOUT INCURRING ANY LIABILITY TO PROVIDE THESE NEW FEATURES ON ANY UNITS PREVIOUSLY MANUFACTURED.

Northshore Manufacturing, Inc.

530 Recycle Center Drive, Two Harbors, Minnesota, U.S.A. 55616

Web: www.builtritehandlers.com E-Mail: info@builtritehandlers.com Phone: 218-834-5555 Fax: 218-834-5556

