

MATERIAL HANDLER

ECO
MODE
READY



Specifications

Standard Machine Weight	101,500 lbs 46 t
Engine Output	255 hp 190 kW
Reach	Up to 59 ft 18 m

Features

- ▶ Fuel saving ECO & ECO+ operating modes enhance flexibility while reducing operating costs
- ▶ Powerful, fuel efficient 255 hp | 190 kW engine matched with hydraulic functions delivers loading cycles with speed and precision while reducing emissions in compliance with Tier 4 interim standards
- ▶ Dedicated slewing circuit for enhanced operating efficiency
- ▶ Hydraulic oil cooler with temperature controlled fan speed is arranged separately from engine cooling systems to optimize performance
- ▶ High resolution, color display with a combination of text and symbols delivers operator comfort and convenience allowing easy monitoring of operating data and conditions

WORKS FOR YOU.™

SPECIFICATIONS

ENGINE

Manufacturer and model	Deutz TCD 7.8 L6 4V
Configuration	6-cylinder inline
Engine control	EMR IV
Type	4-stroke diesel, common rail direct injection, turbocharger, controlled exhaust gas recirculation, diesel particulate filter with automatic regeneration
Engine output power	255 hp 190 kW
Nominal speed	2000 rpm
Displacement	476 in ³ 7.8 L
Cooling system	Coolant / charge air cooling with fan speed control system; optional reversing function
Emission standard	EPA Tier 4 interim / Stage IIIB
Air filter design	Two-stage filter with safety cartridge and pre-separator with discharge valve
Fuel tank capacity	172 gal 653 L
Operating Modes:	
Power Mode	Optimal power and speed for heavy duty applications
ECO Mode	Fuel consumption reduced for medium duty applications
ECO+ Mode	Fuel consumption optimized for light duty applications

ELECTRICAL SYSTEM

Alternator	28 V / 100 A
Operating voltage	24 V
Battery	2 x 12 V / 110 Ah / 750 A (in accordance with EN)
Lighting set	2 x H3 headlamps, turn indicators and tail lights
Generator	30 kW DC generator with controls and insulation monitoring, driven by V-belt direct from diesel engine

TRAVEL DRIVE

Hydrostatic travel drive via infinitely variable axial piston motor with directly mounted travel brake valve, two-speed power shift gear, 4-wheel drive	
Maximum speed, 1st gear	3.1 mph 5 kph
Maximum speed, 2nd gear	9.3 mph 15 kph
Gradeability	30% max
Turning radius	26 ft 8 m

SWING SYSTEM

Swing gear	Internally toothed double-row ball ring gear
Drive	3-stage planetary gear with integrated multi-disc brake
Upper carriage swing speed	Infinitely variable from 0 - 6 rpm
Swing brake	Electrically operated

BRAKE SYSTEM

Service Brake	Hydraulic single circuit braking system acting on all four wheel pairs
Parking Brake	Electrically operated disc brake at transmission, acting on both axles



ELECTRIC DRIVE

Electric drive machine options are available in a variety of stationary or semi-mobile configurations tailored according to customer requirements

HYDRAULIC SYSTEM

REXROTH mobile hydraulic system with load limit control and fuel-saving power demand control; closed swing circuit; hose rupture valves with regeneration on the lift and stick cylinders for efficient work. Hydraulic oil filter elements integrated in the tank; maintenance interval up to 3,000 operating hours

Maximum Pump Capacity	2 x 74 g/min 280 L/min & 37 g/min 140 L/min for swing operation
Maximum Operating Pressure	4,641/5,221 psi 320/360 bar
Hydraulic Oil Tank	141 gal 535 L

UNDERCARRIAGE

Front axle	Planetary drive axle with integrated drum brake, rigidly mounted, max. steering angle 27°
Rear axle	Oscillating planetary drive rear axle with integrated drum brake and selectable oscillating axle lock
Stabilizers	4-point stabilizers
Tires	Solid rubber, 8-ply 12.00 - 24

OPERATOR'S CAB

Elastically supported, infinitely variable hydraulically elevatable with max. eye level of 20 ft | 6.1 m; independent forward movement of up to 7 ft | 2.2 m; Sound-deadened; heat-insulated windows for optimum view; windshield with pull-down sunblind that slides under the cab roof; viewing window on cab roof; sliding window in cab door; height and tilt-adjustable steering column

Heating Infinitely variable hot water heating adjustable defroster nozzles

Operator's Seat: Air-cushioned comfort seat with integrated headrest, safety belt and lumbar support, seat heating with integrated A/C function optional. Seat position, seat inclination and seat cushion multi-adjustable in line with position of armrests and pilot control units, allowing comfortable operation

Monitoring Ergonomic, glare-free instrument layout, multi-function display; automatic monitoring; warning and storage of deviating operating conditions, e.g. filter pressure monitoring with warning indicator or shutdown of pilot controls, warning or shutdown of pilot controls when exceeding maximum hydraulic fluid temperature, diesel particulate filter indicator, rear-view camera

Air conditioning Automatic

Noise level $L_{W(A)} = 104 \text{ dB(A)}$ (guaranteed) in accordance with directive 2000/14 EC

Vibrations: Weighted r.m.s. value of acceleration of upper limbs is below 8.2 f/s^2 | 2.5 m/s^2 .

Weighted r.m.s. value of acceleration for seat area and feet is below 1.6 f/s^2 | 0.5 m/s^2 .

EQUIPMENT

MHL360 E

UNDERCARRIAGE SERIES OPTION

2-speed power-shift transmission	•
4-point stabilizers	•
4-point stabilizers, individually controllable	•
Stabilizer cylinders with integrated two-way check valves	•
All-wheel drive	•
Piston rod protection on stabilizer cylinders	•
Stabilizer plates 20 in x 26 in 510 mm x 665 mm	•
Rear axle oscillating lock	•
Blade in addition to 4-point stabilizers	•
Special paint	•
Drum brakes	•
Tool box	•

UPPERCARRIAGE SERIES OPTION

Electric refuelling pump	•
Lighting protection	•
Maintenance hood, actuated by gas strut, with mechanical locking device	•
Lockable cleaning access openings on radiators	•
Separate radiator system for ambient temperatures up to 122° F 50°C	•
Separate oil cooler with temperature-controlled fan drive	•
Automatic central lubrication system	•
Backup alarm	•
Special paint	•
Quick-drain valve for fuel tank (delivered in tool box)	•
Quick-drain valve on hydraulic oil tank	•
Quick-drain valve on radiator	•
Quick-drain valve on engine oil-pan	•

EQUIPMENT SERIES OPTION

H3 headlights	•
H3 light, mounted on left side of stick	•
Close proximity range limiter for stick	•
Coolant and hydraulic oil level monitoring system	•
Hose rupture protection for lifting cylinders	•
Hose rupture protection for stick cylinders	•
Joystick steering	•
Lubrication of the grab suspension by central lubrication system	•
Overload warning device	•
XENON lights on boom and stick	•
XENON lights on cabin roof	•

ENGINE SERIES OPTION

Turbocharger	•
Charge air cooling	•
Direct electronic fuel injection/ Common Rail	•
Interface for engine diagnosis	•
System controlled fan drive with fan speed monitoring	•

CAB SERIES OPTION

Lift-up skylight in cabin roof	•
Air cushioned operator's seat with headrest, safety belt and lumbar-support	•
Protective grating for cabin, front and top	•
Height and forward adjustable cabin system	•
Air conditioning	•
Steering column, height and tilt adjustable	•
Multi-functional color display	•
Bulletproof glass, front and top	•
Fire extinguisher, dry powder	•
Flashing beacon	•
Sliding window in cab door	•
Safety glass	•
Seat heating	•
Radio / CD Player	•
Windshield washer system	•

ATTACHMENTS SERIES OPTION

Open-tine grapple	•
Half-closed grapple	•
Mag grapple combination	•
Magnet plate	•
Scrap shear	•
Clamshell bucket	•
Log heel	•
Log grapple	•
Pipe handler	•
Load hook	•

WORKS FOR YOU.™

DIMENSIONS

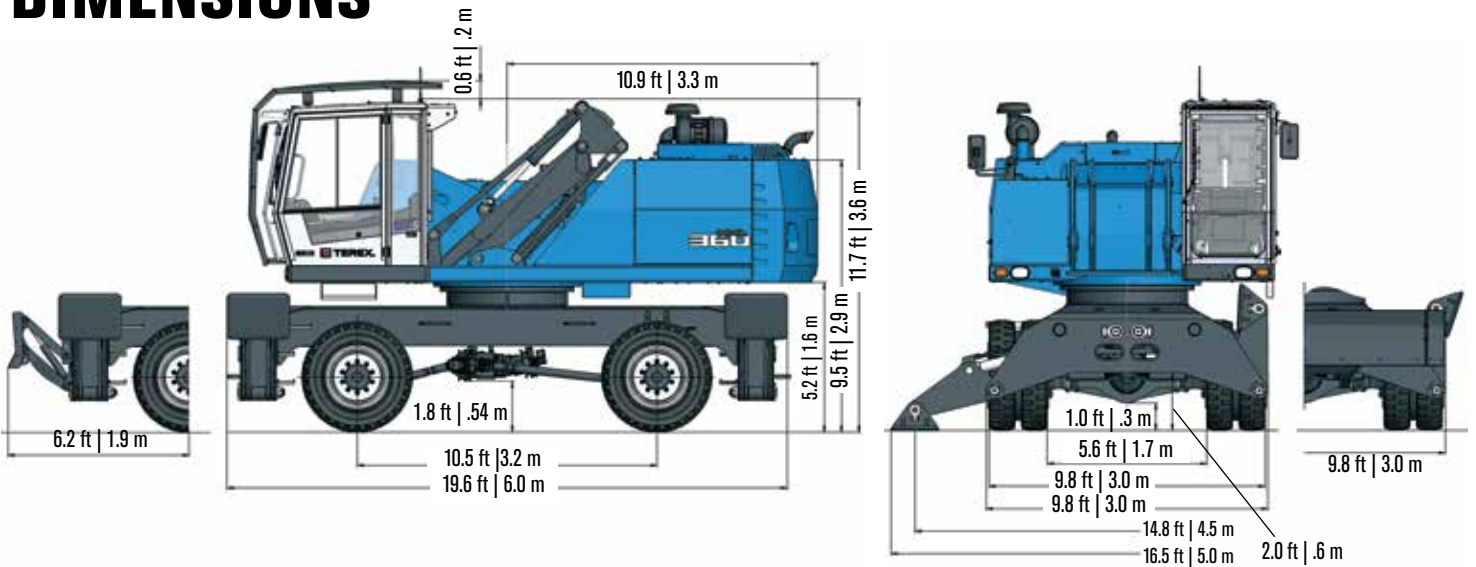

TRANSPORT DIMENSIONS

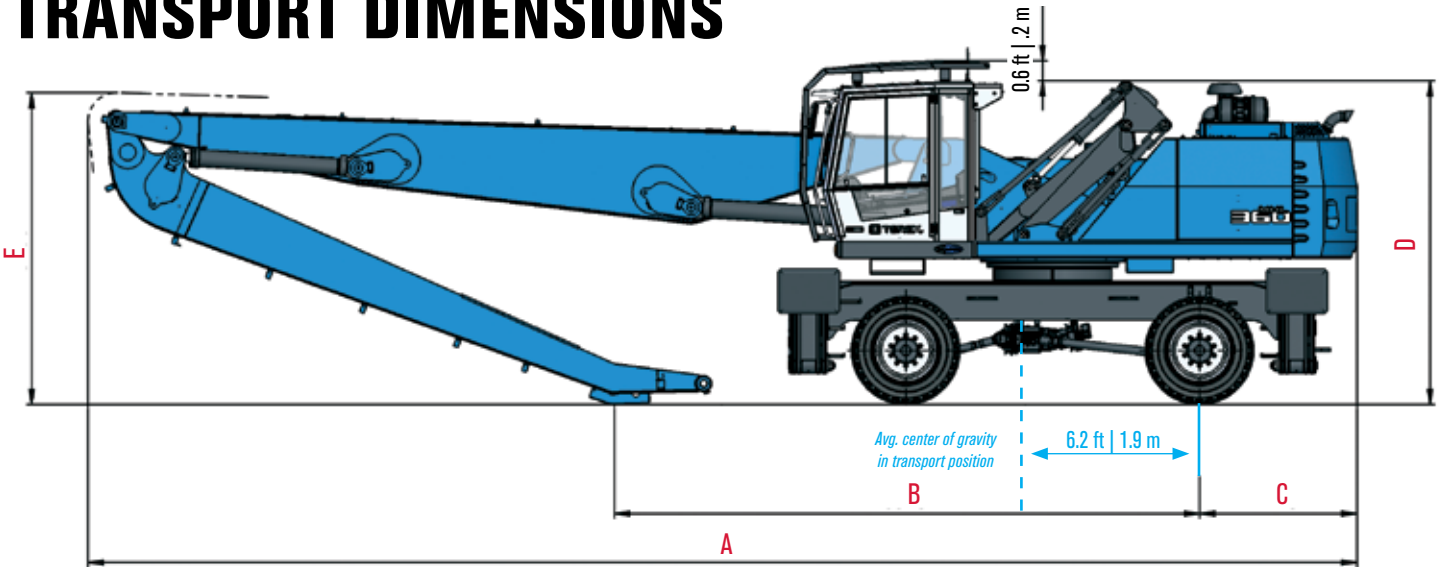

Dimensions

Reach 54 ft | 16.5 m

Reach 59 ft | 18 m

Reach 59 ft | 18m
with cranked boom

	Reach 54 ft 16.5 m	Reach 59 ft 18 m	Reach 59 ft 18m with cranked boom
A	45.4 ft 13.8 m	48.0 ft 14.6 m	47.9 ft 14.6 m
B	20.9 ft 6.3 m	21.0 ft 6.4 m	19.4 ft 5.9 m
C	5.6 ft 1.7 m	5.6 ft 1.7 m	5.6 ft 1.7 m
D	11.7 ft 12.3 ft 3.5 m / 3.7 m	11.7 ft 12.3 ft 3.5 m / 3.7 m	11.7 ft 12.3 ft 3.5 m / 3.7 m
E	11.2 ft 3.4 m	12.1 ft 3.6 m	12.3 ft 3.7 m

* with a protective mesh for the cab roof

LOADING EQUIPMENT MHL360 E

Configuration

Reach 54 ft | 16.5 m

Reach 59 ft | 18 m

Reach 59 ft | 18 m
with cranked boom

Straight boom 29.2 ft 8.9 m	■		
Straight boom 31.8 ft 9.7 m		■	
Cranked boom 31.8 ft 9.7 m			■
Dipperstick 23.0 ft 7.0 m	■		
Dipperstick 25.6 ft 7.8 m		■	■

WORKING RANGES AND LIFTING CAPACITIES **MHL360 E**

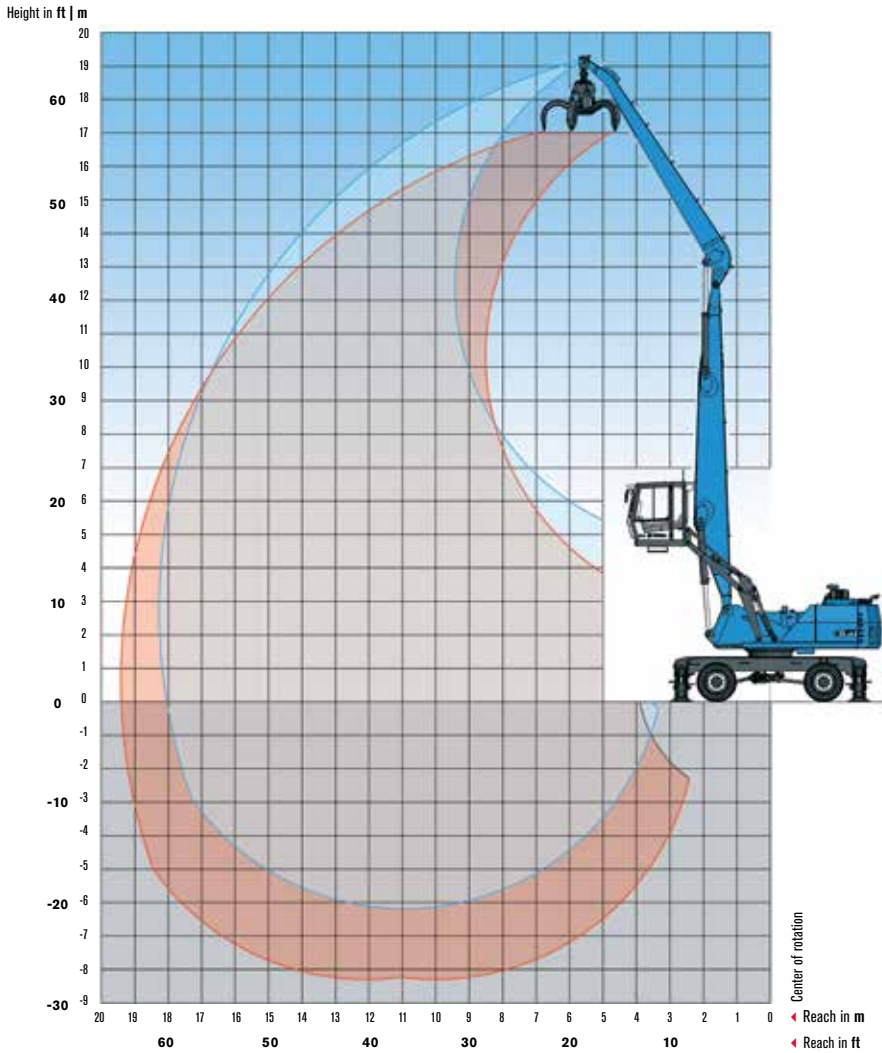

Reach 59 ft | 18 m

Work equipment:
Box-type boom 31.8 ft | 9.7 m
Dipperstick 25.6 ft | 7.8 m

Attachment options:



HEIGHT ft	HEIGHT m	REACH ft	19.7	24.6	29.5	34.4	39.4	44.3	49.2	54.1	59.0
		REACH m	6	7.5	9	10.5	12	13.5	15	16.5	18
49.2	15				19,401* 8.8*	17,417* 7.9*	13,889* 6.3*				
44.3	13.5					16,976* 7.7*	15,432* 7.0*	13,007* 5.9*			
39.4	12					16,976* 7.7*	15,212* 6.9*	13,889* 6.3*	11,244* 5.1*		
34.4	10.5					16,976* 7.7*	15,212* 6.9*	13,889* 6.3*	11,905 5.4		
29.5	9				19,842* 9.0*	17,417* 7.9*	15,432* 7.0*	13,889* 6.3*	11,905 5.4	9,921 4.5	
24.6	7.5				20,503* 9.3*	17,857* 8.1*	15,873* 7.2*	14,110* 6.4*	11,684 5.3	9,921 4.5	
19.7	6			26,015* 11.8*	21,605* 9.8*	18,519* 8.4*	16,094* 7.3*	13,669 6.2	11,464 5.2	9,700 4.4	
14.8	4.5	48,502* 22.0*	36,376* 16.5*	27,778* 12.6*	22,708* 10.3*	18,960* 8.6*	16,094 7.3	13,228 6.0	11,244 5.1	9,700 4.4	8,157 3.7
9.8	3		39,242* 17.8*	29,321* 13.3*	23,369* 10.6*	18,960 8.6	15,432 7.0	13,007 5.9	11,023 5.0	9,480 4.3	8,157 3.7
4.9	1.5		20,062* 9.1*	29,101* 13.2*	22,487 10.2	18,078 8.2	14,771 6.7	12,566 5.7	10,582 4.8	9,259 4.2	8,157* 3.7*
0	0		15,212* 6.9*	27,778 12.6	21,385 9.7	17,417 7.9	14,330 6.5	12,125 5.5	10,362 4.7	9,039 4.1	7,275* 3.3*
-4.9	-1.5		15,212* 6.9*	26,676* 12.1*	20,723 9.4	16,755 7.6	14,110 6.4	11,905 5.4	10,362 4.7	8,598* 3.9*	
-9.8	-3		16,535* 7.5*	23,589* 10.7*	19,621* 8.9*	16,535* 7.5*	13,669* 6.2*	11,684* 5.3*	9,480* 4.3*	7,055* 3.2*	
-14.8	-4.5			19,401* 8.8*	16,755* 7.6*	14,110* 6.4*	11,905* 5.4*	9,700* 4.4*	7,496* 3.4*		
-19.7	-6					11,023* 5.0*	9,039* 4.1*				

Capacity values are stated in pounds | metric tons. The pump pressure is 5,221 psi | 360 bar. The values, in accordance with ISO 10567, represent 75% of the static tipping load or 87% of the hydraulic lifting force (marked *). Values apply to 4-pt supported slewing operations over 360 degrees on a firm and level surface.

The weight of the attached hoisting equipment (coupler, grapple, magnet, clamshell, load hook etc.) must be deducted from the capacity values in accordance with CE guidelines, hose-rupture protection valves on the lift cylinders and an overload warning device are required for crane operations.

WORKS FOR YOU.™

MHL360 E

Reach 54 ft | 16.5 m

Work equipment:
 Box-type boom 29.2 ft | 8.9 m
 Dipperstick 23 ft | 7 m

Attachment options:

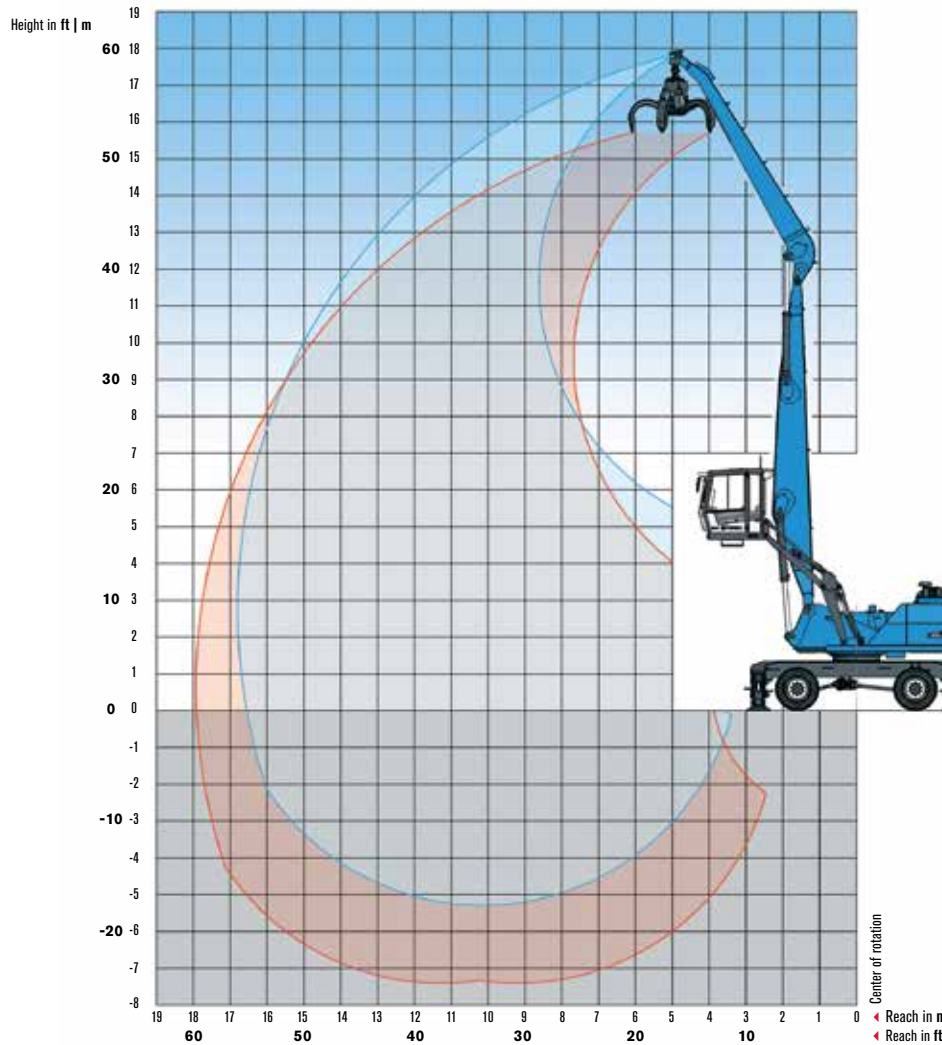

HEIGHT ft	HEIGHT m	REACH ft 14.8	19.7	24.6	29.5	34.4	39.4	44.3	49.2	54.1
		REACH m 4.5	6	7.5	9	10.5	12	13.5	15	16.5
49.2	15				18,519* 8.4*	12,787* 5.8*				
44.3	13.5				20,503* 9.3*	18,298* 8.3*	12,787* 5.8*			
39.4	12				20,283* 9.2*	18,078* 8.2*	16,535* 7.5*	11,023* 5.0*		
34.4	10.5				20,283* 9.2*	18,078* 8.2*	16,314* 7.4*	14,330 6.5		
29.5	9				20,723* 9.4*	18,298* 8.3*	16,535* 7.5*	14,110 6.4	11,684 5.3	
24.6	7.5			24,692* 11.2*	21,385* 9.7*	18,739* 8.5*	16,755* 7.6*	14,110 6.4	11,684 5.3	
19.7	6		32,628* 14.8*	26,896* 12.2*	22,487* 10.2*	19,401* 8.8*	16,755 7.6	13,889 6.3	11,464 5.2	
14.8	4.5	52,911* 24.0*	37,479* 17.0*	28,881* 13.1*	23,589* 10.7*	19,842* 9.0*	16,314 7.4	13,448 6.1	11,464 5.2	9,700 4.4
9.8	3		40,565* 18.4*	30,424* 13.8*	24,030* 10.9*	19,180 8.7	15,653 7.1	13,228 6.0	11,244 5.1	9,700 4.4
4.9	1.5		26,896* 12.2*	29,983 13.6	22,928 10.4	18,519 8.4	15,212 6.9	12,787 5.8	11,023 5.0	9,480 4.3
0	0		20,062* 9.1*	28,660 13.0	22,046 10.0	17,857 8.1	14,771 6.7	12,566 5.7	10,803 4.9	8,378* 3.8*
-4.9	-1.5		19,621* 8.9*	27,778* 12.6*	21,605 9.8	17,417 7.9	14,551 6.6	12,346 5.6	10,141 4.6	
-9.8	-3		21,164* 9.6*	24,030* 10.9*	20,062* 9.1*	16,535* 7.5*	13,669* 6.2*	11,023* 5.0*	7,937* 3.6*	
-14.8	-4.5			19,180* 8.7*	16,314* 7.4*	13,669* 6.2*	11,023* 5.0*			

Capacity values are stated in pounds | metric tons. The pump pressure is 5,221 psi | 360 bar. The values, in accordance with ISO 10567, represent 75% of the static tipping load or 87% of the hydraulic lifting force (marked *). Values apply to 4-pt supported slewing operations over 360 degrees on a firm and level surface.

The weight of the attached hoisting equipment (coupler, grapple, magnet, clamshell, load hook etc.) must be deducted from the capacity values in accordance with CE guidelines, hose-rupture protection valves on the lift cylinders and an overload warning device are required for crane operations.

WORKS FOR YOU.™



TEREX® | FUCHS



Telematics SYSTEM

CONNECTS FOR YOU

The new Terex Fuchs Telematics system available on E series machines* offers a modern solution to help you analyze and optimize the efficiency of your machines. The Terex Fuchs Telematics system records and communicates valuable information on the operating status of each individual machine. Where are the machines? How are they working? Is a service check pending? Take advantage of this advanced software and get a handle on your fleet management with the tool that connects for you.



Mobile		MHL320	MHL331	MHL335	MHL340	MHL345	MHL350	MHL355	MHL360	MHL365	MHL380	MHL385
	TIER 3 TIER 4i [kW]	85/-	114/115	114/115	128/129	128/129	148/160	148/160	186/190	186/190	273/-	273/-
	[hp]	114/-	153/154	153/154	172/173	171/172	199/215	199/216	249/255	249/255	366/-	366/-
	Electric Drive [kW]	100	132	132	132	132	155	155	184	184	279	279
	[hp]	134	177	177	177	177	208	208	246	246	374	374
	[m]	8.2-10.4	8.2-10.4	10.7-12.0	12.2-13.7	12.2-13.7	14.0-16.0	14.0-17.0	16.5-18.0	16.5-19.0	18.5-22.0	18.5-23.0
	[ft]	26.9-34.1	26.9-34.1	35.1-39.4	40.0-45.0	40.0-45.0	45.9-52.5	45.9-55.7	54.1-59.1	54.1-62.3	60.7-72.2	60.6-75.4
	up to [t]	19.0	23.5	25.0	29.0	30.0	35.5	38.0	46.8	55.0	67.0	73.5
	up to [lbs]	41,887	51,809	55,116	63,934	66,139	78,264	83,776	101,413	121,254	147,709	162,039
Crawler		RHL320	RHL331	RHL335	RHL340	RHL345	RHL350	RHL355	RHL360	RHL365	RHL380	RHL385
	up to [t]	24	30.5	30.5	38	40	41.5	48	64.0	65.0	76.0	-
	up to [lbs]	52,911	67,241	67,241	83,776	88,185	91,492	105,822	119,049	143,300	167,551	-

www.terex.com/construction

*Effective production date June 2014

Effective Date: August 2014. Product specifications and prices are subject to change without notice or obligation. The photographs and/or drawings in this document are for illustrative purposes only. Refer to the appropriate Operator's Manual for instructions on the proper use of this equipment. Failure to follow the appropriate Operator's Manual when using our equipment or to otherwise act irresponsibly may result in serious injury or death. The only warranty applicable to our equipment is the standard written warranty applicable to the particular product and sale and Terex makes no other warranty, express or implied. Products and services listed may be trademarks, service marks, or trade names of Terex Corporation and/or its subsidiaries in the USA and other countries. All rights are reserved. © 2014 Terex Construction. Terex, Terex Fuchs and Works For You trademarks owned or licensed by Terex Corporation or its subsidiaries.

Terex Construction 8800 Rostin Road, Southaven, MS 38671 USA
Tel +1 (888) 90-TEREX www.terex.com/construction



TEREX®

WORKS FOR YOU.™

MHL360E 032014 PN 380108