

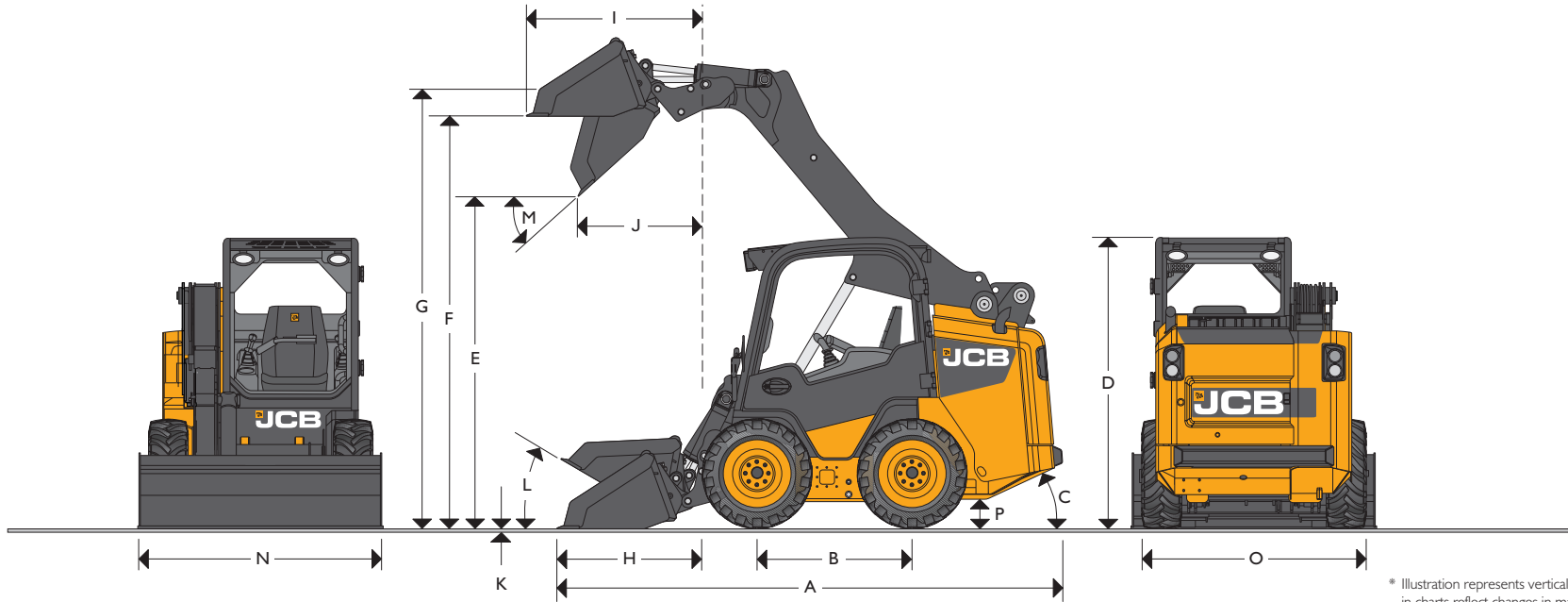

JCB SMALL PLATFORM SKID STEER AND COMPACT TRACK LOADERS

RATED OPERATING CAPACITY: 135 1,350 lb (612 kg) 155 1,550 lb (703 kg) 175 1,750 lb (794 kg) 190 1,900 lb (862 kg) 205 2,050 lb (930 kg)



* Illustration represents vertical lift machine. Specs in charts reflect changes in machines due to lift path.

STATIC DIMENSIONS – 135 / 155 / 175 / 190 / 205

Machine Models	135	155	175	190	205
	ft-in (m)	ft-in (m)	ft-in (m)	ft-in (m)	ft-in (m)
A Overall Length	11-5 (3.49)	11-5 (3.49)	11-7 (3.53)	11-8 (3.56)	11-10 (3.61)
B Wheel Base	3-6 (1.07)	3-6 (1.07)	3-6 (1.07)	3-6 (1.07)	3-6 (1.07)
C Angle of Departure	25°	25°	25°	25°	25°
D Overall Height	6-6 (1.98)	6-6 (1.98)	6-6 (1.98)	6-6 (1.98)	6-6 (1.98)
E Dump Height	7-5 (2.26)	7-5 (2.26)	7-5 (2.26)	7-5 (2.26)	7-5 (2.26)
F Loadover Height	9-4 (2.84)	9-4 (2.84)	9-4 (2.84)	9-4 (2.84)	9-4 (2.84)
G Height to Hinge Pin Fully Raised	9-10 (3.00)	9-10 (3.00)	9-10 (3.00)	9-10 (3.00)	9-10 (3.00)
H Reach @ Ground Level (cutting edge)	3-3 (1.00)	3-3 (1.00)	3-3 (1.00)	3-3 (1.00)	3-3 (1.00)
I Max Reach @ Full Height	3-0 (.91)	3-0 (.91)	3-2 (.97)	3-3 (.99)	3-5 (1.04)
J Reach @ Full Height - Fully Dumped	1-10 (.56)	1-10 (.56)	2-9 (.86)	2-9 (.86)	2-9 (.86)
K Dig Depth (toe plate horizontal) Clearance	in (mm)	-0.4 (-10)	-0.4 (-10)	-0.4 (-10)	-0.4 (-10)
L Rollback @ Ground	degrees	30°	30°	30°	30°

Machine Models	135	155	175	190	205	
	ft-in (m)	ft-in (m)	ft-in (m)	ft-in (m)	ft-in (m)	
M Dump Angle	degrees	42°	42°	42°	42°	
N Bucket Width - Standard	5-0 (1.52)	5-5 (1.68)	5-5 (1.68)	5-8 (1.73)	6-0 (1.83)	
Bucket Width - Optional	4-6 (1.37)	5-0 (1.52)	5-8 (1.73)	6-0 (1.83)	5-8 (1.68)	
O Width Over Tires - Standard	4-11 (1.52)	5-3 (1.60)	5-3 (1.60)	5-3 (1.60)	5-3 (1.60)	
Width Over Tires - Optional	4-5 (1.37)	5-0 (1.52)	5-0 (1.52)	5-0 (1.52)	5-0 (1.52)	
Rated Operating Capacity	lb SAE (kg)	1350 (612.3)	1550 (703.1)	1750 (793.8)	1900 (861.8)	2050 (929.9)
Bucket Capacity - Standard	yd ³ (m ³)	.47 (.36)	.52 (.40)	.52 (.40)	.53 (.41)	.57 (.44)
Turning Radius						
Bucket Corner Radius	6-10 (2.09)	6-10 (2.09)	6-10 (2.09)	6-10 (2.09)	6-10 (2.09)	
Quick Hitch Radius	3-7 (1.10)	3-7 (1.10)	3-9 (1.14)	3-9 (1.14)	3-9 (1.14)	
Rear Chassis Radius	5-5 (1.65)	5-5 (1.65)	5-5 (1.65)	5-5 (1.65)	5-5 (1.65)	
P Ground Clearance	in (mm)	8.3 (210)	8.3 (210)	8.3 (210)	8.3 (210)	8.3 (210)
Lift Path	Radial	Radial	Vertical	Vertical	Vertical	



JCB SMALL PLATFORM SKID STEER AND COMPACT TRACK LOADERS

RATED OPERATING CAPACITY: 150T 1,500 lb (681 kg) 190T 1,900 lb (862 kg) 205T 2,050 lb (930 kg)

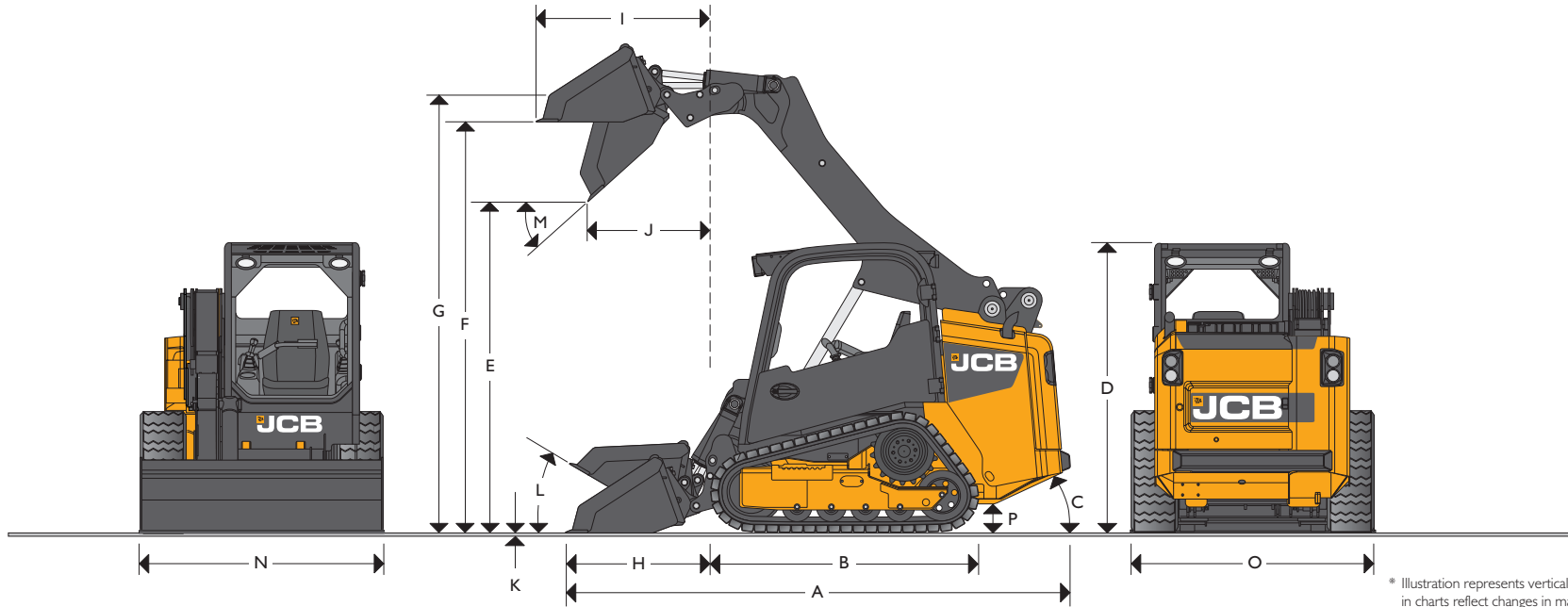

* Illustration represents vertical lift machine. Specs in charts reflect changes in machines due to lift path.

STATIC DIMENSIONS – 150T / 190T / 205T

Machine Models	150T ft-in (m)	190T ft-in (m)	205T ft-in (m)
A Overall Length	11-5 (3.49)	11-7 (3.53)	11-9 (3.58)
B Track Base	5-10 (1.78)	5-10 (1.78)	5-10 (1.78)
C Angle of Departure	27°	27°	27°
D Overall Height	6-7 (2.00)	6-7 (2.00)	6-7 (2.00)
E Dump Height	7-6 (2.29)	7-6 (2.29)	7-6 (2.29)
F Loadover Height	9-4 (2.85)	9-4 (2.85)	9-4 (2.85)
G Height to Hinge Pin Fully Raised	9-11 (3.02)	9-11 (3.02)	9-11 (3.02)
H Reach @ Ground Level	3-7 (1.09)	3-3 (1.00)	3-3 (1.00)
I Max Reach @ Full Height	3-3 (0.99)	4-0 (1.21)	4-0 (1.21)
J Reach @ Full Height - Fully Dumped	2-1 (0.64)	2-9 (0.85)	2-9 (0.85)
K Dig Depth Clearance	-0.4 (-10)	-0.4 (-10)	-0.4 (-10)
L Rollback @ Ground	30°	30°	30°
M Dump Angle	42°	42°	42°

Machine Models	150T ft-in (m)	190T ft-in (m)	205T ft-in (m)
N Bucket Width - Standard	5-8 (1.73)	5-8 (1.73)	6-0 (1.83)
Bucket Width - Optional	5-6 (1.68)	6-0 (1.83)	5-8 (1.73)
O Width Over Tracks - Standard	5-5 (1.65)	5-5 (1.65)	5-5 (1.65)
Width Over Tracks - Optional	5-5 (1.65)	5-5 (1.65)	5-5 (1.65)
Rated Operating Capacity	lb SAE (kg)	1500 (680.4)	1900 (861.8)
Bucket Capacity - Standard	yd ³ (m ³)	.53 (.41)	.53 (.41)
Turning Radius			
Bucket Corner Radius	6-10 (2.09)	6-10 (2.09)	6-10 (2.09)
Quick Hitch Radius	3-9 (1.10)	3-9 (1.14)	3-9 (1.14)
Rear Chassis Radius	5-5 (1.65)	5-5 (1.65)	5-5 (1.65)
P Ground Clearance	in (mm)	9.1 (230)	9.1 (230)
Ground Bearing Pressure*	psi (Kp)	6.75 (46.6)	6.20 (42.6)
Lift Path	Radial	Vertical	Vertical

* with 12.6" wide tracks (320 mm)



JCB LARGE PLATFORM SKID STEER AND COMPACT TRACK LOADERS

RATED OPERATING CAPACITY: 225 2,250 lb (1,021 kg) 260 2,600 lb (1,179 kg) 280 2,800 lb (1,270 kg) 300 3,000 lb (1,361 kg) 330 3,295 lb (1,495 kg)

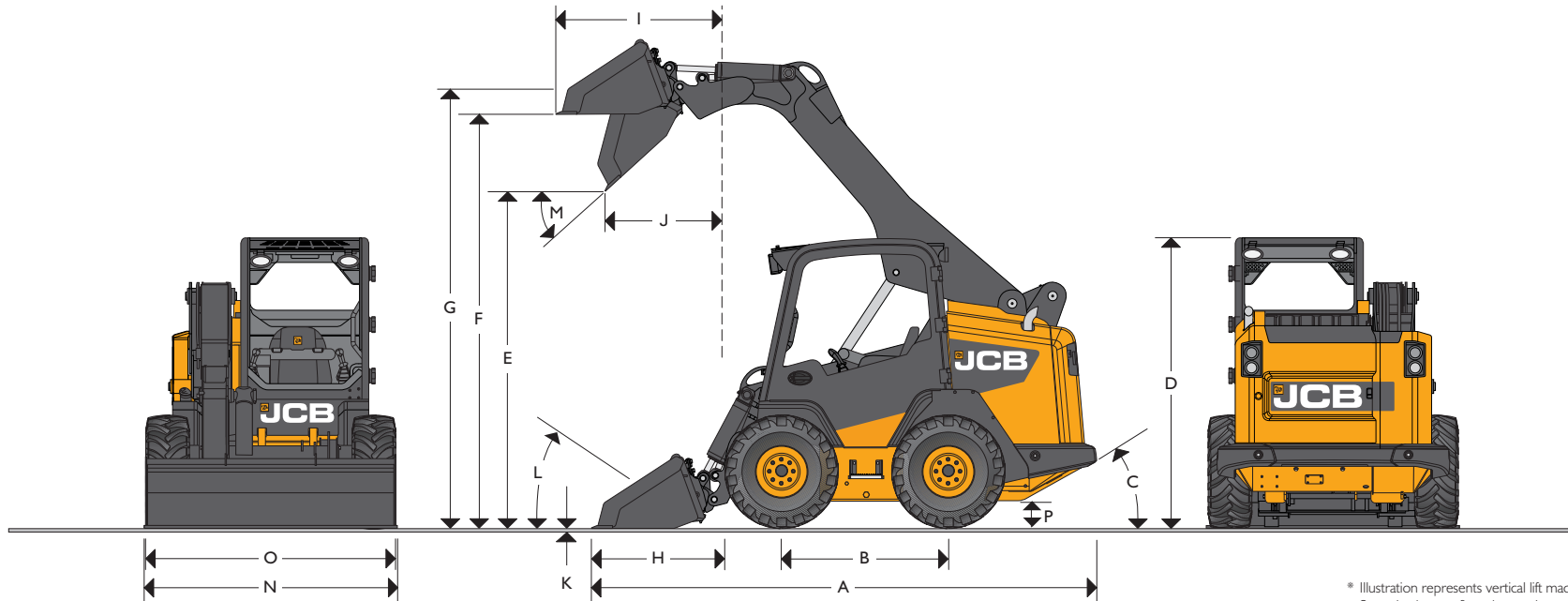

* Illustration represents vertical lift machine.
Specs in charts reflect changes in machines due to lift path.

STATIC DIMENSIONS – 225 / 260 / 280 / 300 / 330

Machine Models	225	260	280	300	330
	ft-in (m)	ft-in (m)	ft-in (m)	ft-in (m)	ft-in (m)
A Overall Length	12-2 (3.69)	12-2 (3.69)	12-4 (3.76)	12-5 (3.78)	12-7 (3.80)
B Wheel Base	4-0 (1.22)	4-0 (1.22)	4-0 (1.22)	4-0 (1.22)	4-0 (1.22)
C Angle of Departure	28.7°	28.7°	28.7°	28.7°	29.1°
D Overall Height	6-10 (2.09)	6-10 (2.09)	6-10 (2.09)	6-10 (2.09)	6-11 (2.11)
E Dump Height	8-1 (2.46)	8-1 (2.46)	8-1 (2.46)	8-1 (2.46)	8-2 (2.49)
F Loadover Height	9-10 (3.02)	9-10 (3.02)	9-10 (3.02)	9-10 (3.02)	10 (3.05)
G Height to Hinge Pin Fully Raised	10-5 (3.175)	10-5 (3.175)	10-5 (3.175)	10-5 (3.175)	10-6 (3.2)
H Reach @ Ground Level	3-2.5 (0.98)	3-2.5 (0.98)	3-2.5 (0.98)	3-5 (1.04)	3-5 (1.04)
I Max Reach @ Full Height	3-2 (.96)	4-0.5 (1.23)	4-0.5 (1.23)	4-0.5 (1.23)	3-11 (1.2)
J Reach @ Full Height - Fully Dumped	1-11 (.59)	2-10 (0.87)	2-10 (0.87)	2-11 (0.90)	2-11 (0.90)
K Dig Depth (toe plate horizontal) Clearance	-3/8 (-10)	-3/8 (-10)	-3/8 (-10)	-3/8 (-10)	0
L Rollback @ Ground	30°	30°	30°	30°	29°

Machine Models	225	260	280	300	330
	ft-in (m)	ft-in (m)	ft-in (m)	ft-in (m)	ft-in (m)
M Dump Angle	42°	42°	42°	42°	42°
N Bucket Width - Standard	6-0 (1.82)	6-0 (1.82)	6-0 (1.82)	6-0 (1.82)	6-6 (1.98)
O Width Over Tires - Standard	6-0 (1.82)	6-0 (1.82)	6-0 (1.82)	6-0 (1.82)	6-2 (1.87)
Width Over Tires - Optional	6-2 (1.87)	6-2 (1.87)	6-2 (1.87)	6-2 (1.87)	6-0 (1.82)
Rated Operating Capacity 50%	2250 (1021)	2600 (1179)	2800 (1270)	3000 (1361)	3295 (1495)
Bucket Capacity - Standard	.62 (.47)	.62 (.47)	.62 (.47)	.67 (.51)	.67 (.51)
Turning Radius					
Bucket Corner Radius	7-3 (2.20)	7-3 (2.20)	7-3 (2.20)	7-3 (2.20)	7-3 (2.20)
Quick Hitch Radius	4-10.5 (1.48)	4-10.5 (1.48)	4-10.5 (1.48)	4-10.5 (1.48)	4-10.5 (1.48)
Rear Chassis Radius	5-9.5 (1.76)	5-9.5 (1.76)	5-9.5 (1.76)	5-9.5 (1.76)	5-9.5 (1.76)
P Ground Clearance	9.4 (238)	9.4 (238)	9.4 (238)	9.4 (238)	9.8 (248)
Lift Path	Radial	Vertical	Vertical	Vertical	Vertical



JCB LARGE PLATFORM SKID STEER AND COMPACT TRACK LOADERS

RATED OPERATING CAPACITY: 225T 2,250 lb (1,021 kg) 260T 2,600 lb (1,179 kg) 300T 3,000 lb (1,361 kg) 320T 3,200 lb (1,452 kg)

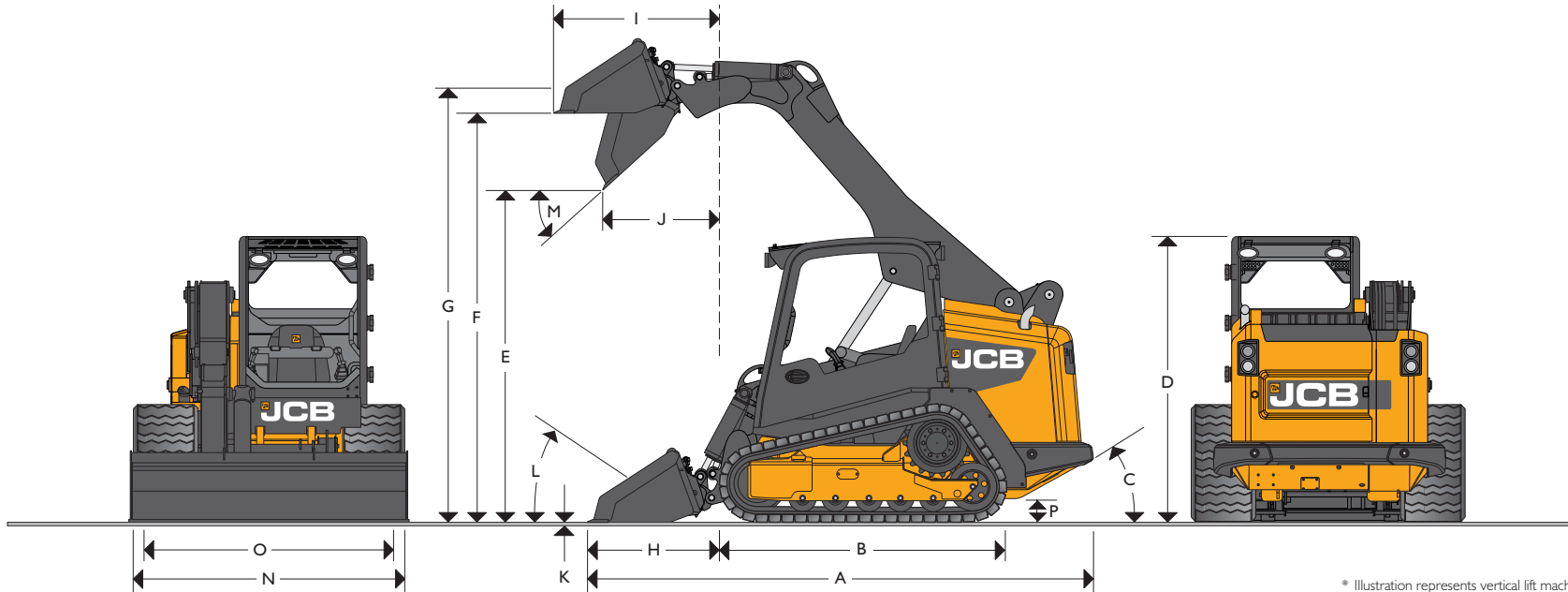

* Illustration represents vertical lift machine.
Specs in charts reflect changes in machines due to lift path.

STATIC DIMENSIONS – 225T / 260T / 300T / 320T

Machine Models		225T	260T	300T	320T
		ft-in (m)	ft-in (m)	ft-in (m)	ft-in (m)
A	Overall Length	12-2 (3.69)	12-2 (3.69)	12-5 (3.78)	12-5 (3.78)
B	Track Base	6-11 (2.1)	6-11 (2.1)	6-11 (2.1)	6-11 (2.1)
C	Angle of Departure	degrees 28.7°	degrees 28.7°	degrees 28.7°	degrees 28.7°
D	Overall Height	6-10 (2.08)	6-10 (2.08)	6-10 (2.08)	6-10 (2.08)
E	Dump Height	7-11 (2.42)	7-11 (2.42)	7-10 (2.39)	7-10 (2.39)
F	Loadover Height	9-10 (2.99)	9-10 (2.99)	9-10 (2.99)	9-10 (2.99)
G	Height to Hinge Pin Fully Raised	10-5 (3.18)	10-5 (3.18)	10-5 (3.18)	10-5 (3.18)
H	Reach @ Ground Level	3-2 (0.96)	3-2 (0.96)	3-5 (1.04)	3-5 (1.04)
I	Max Reach @ Full Height	3-1 (.935)	4 (1.21)	4.3 (1.30)	4.3 (1.30)
J	Reach @ Full Height - Fully Dumped	1-11 (.585)	2-10.5 (0.87)	2-11 (0.90)	2-11 (0.90)
K	Dig Depth Clearance	in (mm) -3/8 (-10)	in (mm) -3/8 (-10)	in (mm) -3/8 (-10)	in (mm) -3/8 (-10)
L	Rollback @ Ground	degrees 30°	degrees 30°	degrees 30°	degrees 30°

Machine Models		225T	260T	300T	320T
		ft-in (m)	ft-in (m)	ft-in (m)	ft-in (m)
M	Dump Angle	degrees 42°	degrees 42°	degrees 42°	degrees 42°
N	Bucket Width - Standard	6-6 (1.98)	6-6 (1.98)	7-0 (2.13)	7-0 (2.13)
O	Width Over Tracks - Standard	6-1 (1.85)	6-6 (1.98)	6-6 (1.98)	6-6 (1.98)
	Rated Operating Capacity 35%	lb (kg) 2250 (1021)	2600 (1179)	3000 (1361)	3200 (1452)
	Rated Operating Capacity 50%	lb (kg) 3214 (1458)	3994 (1812)	4314 (1957)	4573 (2074)
	Bucket Capacity - Standard	yd ³ (m ³) .79 (.59)	.79 (.59)	.84 (.64)	.84 (.64)
Turning Radius					
	Bucket Corner Radius	7-4.5 (2.24)	7-4.5 (2.24)	7-4.5 (2.24)	7-4.5 (2.24)
	Quick Hitch Radius	4-10.5 (1.48)	4-10.5 (1.48)	4-10.5 (1.48)	4-10.5 (1.48)
	Rear Chassis Radius	5.95 (1.76)	5.95 (1.76)	5.95 (1.76)	5.95 (1.76)
P	Ground Clearance	in (mm) 9.8 (248)	9.8 (248)	9.8 (248)	9.8 (248)
	Ground Bearing Pressure*	psi (Kp) 4.36 (30.1)	4.6 (31.7)	4.8 (33.1)	4.9 (33.8)
Lift Path					
		Radial	Vertical	Vertical	Vertical

* with 17.7" wide tracks (450 mm)



HYDRAULIC PERFORMANCE - SMALL PLATFORM

Model	R.O.C. lb (kg)	Tipping Load lb (kg)	Loader Lift lb (kg)	Bucket Tilt lb (kg)
135	1350 (612)	2989 (1356)	3175 (1440)	4012 (1820)
155	1550 (703)	3100 (1406)	3902 (1770)	4012 (1820)
175	1750 (794)	3500 (1587)	3461 (1570)	4718 (2140)
190	1900 (862)	3800 (1723)	3461 (1570)	4718 (2140)
205	2050 (930)	4100 (1859)	3461 (1570)	4718 (2140)
150T	1500 (680)	4334 (1966)	3902 (1770)	4012 (1820)
190T	1900 (862)	5429 (2462)	3461 (1570)	4718 (2140)
205T	2050 (930)	5857 (2656)	3461 (1570)	4718 (2140)

HYDRAULICS - SMALL PLATFORM

In addition to the main hydrostatic drive pumps, there is a dedicated loader and attachments supply pump (auxiliary hydraulics circuit standard on all base models). High flow is optional on all models except the 135.

Pump Flow: 18.5 gpm (70 lpm) @ 2800 rpm engine speed
 Main relief pressure 3335 psi (230 bar)
 HYD HP Low Flow (36.0)*
 HYD HP High Flow (51.4)* *calculated

- Low lever efforts give excellent and easy control of transmission loader and attachments.
- Auxiliary hydraulics are actuated via the right hand controller giving progressive control of oil flow for precise attachment control (left hand controller location on optional 7 way multi-function joysticks).
- Loader arm hydraulic lines under protective steel guard on PowerBoom.
- Canister style, full flow, hydraulic oil filter.
- JCB engine oil for engine and chain case.
- JCB hydraulic oil.
- The optional High Flow circuit provides 26.4 gal/min (100 liters/min) pump flow to the front of the machine for operation of high capacity attachments such as trenchers and cold planers.
- Separate hydraulic pump for transmission charge and hydraulic fan.

CAPACITIES - SMALL PLATFORM

	gal (l)
Hydraulic System (including tank)	11.1 (42)
Fuel Tank	25.9 (98)
Engine Coolant	4.0 (15)
Engine Oil	2.6 (10)
LH Chaincase (wheeled machines only)	2.0 (7.6)
RH Chaincase (wheeled machines only)	2.0 (7.6)

HYDRAULIC PERFORMANCE - LARGE PLATFORM

Model	R.O.C. lb (kg)	Tipping Load lb (kg)	Loader Lift lb (kg)	Bucket Tilt lb (kg)
225	2250 (1021)	4908 (2226)	5884 (2669)	5699 (2585)
260	2600 (1179)	5448 (2471)	5884 (2669)	5699 (2585)
280	2800 (1270)	5608 (2543)	5884 (2669)	5699 (2585)
300	3000 (1361)	6024 (2732)	5809 (2634)	7187 (3260)
330	3295 (1495)	6590 (2989)	5809 (2634)	7187 (3260)
225 T	2250 (1021)	6428 (2915)	5884 (2669)	5699 (2585)
260 T	2600 (1179)	7991 (3624)	5809 (2634)	7187 (3260)
300 T	3000 (1361)	8628 (3913)	5809 (2634)	7187 (3260)
320 T	3200 (1452)	9145 (4148)	5809 (2634)	7187 (3260)

HYDRAULICS - LARGE PLATFORM

In addition to the main hydrostatic drive pumps, there is a dedicated loader and attachments supply pump (auxiliary hydraulics circuit standard on all base models).

Pump Flow: 24 gpm (90 lpm) @ 2200 rpm engine speed
 Main relief pressure 3335 psi (230 bar)
 HYD HP Low Flow (46.7)*
 HYD HP High Flow (64.2)* *calculated

- Low lever efforts give excellent and easy control of transmission loader and attachments.
- Auxiliary hydraulics are actuated via the right hand controller giving progressive control of oil flow for precise attachment control.
- Loader arm hydraulic lines under protective steel guard on PowerBoom.
- Canister style, full flow, hydraulic oil filter.
- JCB engine oil for engine and chain case.
- JCB hydraulic oil.
- The optional High Flow circuit provides 33 gal/min (125 liters/min) pump flow to the front of the machine for operation of high capacity attachments such as trenchers and cold planers.
- Separate hydraulic pump for transmission charge and hydraulic fan.

CAPACITIES - LARGE PLATFORM

	gal (l)
Hydraulic System (including tank)	15.9 (60)
Fuel Tank	27.2 (103)
Engine Coolant	4.1 (15.5)
Engine Oil	3.7 (14)
LH Chaincase (wheeled machines only)	3.1 (11.7)
RH Chaincase (wheeled machines only)	3.1 (11.7)



ENGINE - SMALL PLATFORM

		135	155/175/150T	190/205/190T/205T
Model		Kohler KDI 1903 TCR	Kohler KDI 1903 TCR	Kohler KDI 2504 TCR
Displacement	in ³ (cm ³)	113.5 (1,860)	113.5 (1,860)	151.4 (2,481)
Fuel		Diesel	Diesel	Diesel
Cooling		Liquid	Liquid	Liquid
Aspiration		Turbo	Turbo	Turbo
Gross Power @ 2800 rpm				
SAE J1995	hp (kW)	48 (36)	56 (42)	62 (46)
Gross Torque @ 1200 rpm				
SAE J1995	lb/ft (Nm)	165.9 (225)	165.9 (225)	221.2 (300)
Starter Motor	hp (kW)	2.72 (2)	2.72 (2)	2.72 (2)
Battery	V/Ah	12/109	12/109	12/109
Alternator	amps	80	100	100
Emission Certification		EPA-T4F (EU St3B)	EPA-T4F(EU St3B)	EPA-T4F(EU St3B)
Engine Oil Service Interval Hours		500	500	500
Variable Speed Hydraulically Driven Fan		YES	YES	YES

ENGINE - LARGE PLATFORM

		225/260/280/225T/260T/300/330/300T/320T
Model		EcoMAX TCAE-55
Displacement	in ³ (cm ³)	268 (4399)
Fuel		Diesel
Cooling		Water
Aspiration		Turbo
Gross Power @ 2400 rpm		
SAE J1995	hp (kW)	74 (55)
Gross Torque @ 1200 rpm		
SAE J1995	lb/ft (Nm)	295 (400)
Starter Motor	hp (kW)	5.63 (4.2)
Battery	V/Ah	12 / 109
Alternator	amps	95
Emission Certification		EPA-T4F (EU St3B)
Engine Oil Service Interval Hours		500
Variable Speed Hydraulically Driven Fan		YES

TRANSMISSION - SMALL PLATFORM

A full servo controlled hydrostatic transmission giving zero to maximum speed, both forward and reverse at full power. Independent transmission systems for both the left and right side, controlled through servo controls for both precise and easy operation. Transmission power system maintains full engine power availability maximizing loader and attachment control.

Model	Single Speed	Two Speed
	mph (km/h)	mph (km/h) / mph (km/h)
Travel Speeds 135:	7.5 (12.0)	N/A
Travel Speeds 155/175/190/205:	7.5 (12.0)	5.6 (9.0) / 11.5 (18.5)
Travel Speeds 150T/190T/205T:	6.2 (10.0)	5.6 (9.0) / 7.8 (12.6)

TRANSMISSION - LARGE PLATFORM

A full servo controlled hydrostatic transmission giving zero to maximum speed, both forward and reverse at full power. Independent transmission systems for both the left and right side, controlled through servo controls for both precise and easy operation. Transmission power system maintains full engine power availability maximizing loader and attachment control.

Model	Single Speed	Two Speed
	mph (km/h)	mph (km/h) / mph (km/h)
Travel Speeds 225/260/280/300:	6.8 (10.9)	6.8 (10.9) / 12.4 (20)
Travel Speeds 330:	7.3 (11.7)	7.3 (11.7) / 13.5 (21.7)
Travel Speeds 225T/260T/300T/320T:	5.7 (9.2)	4.8 (7.7) / 7.8 (12.6)

SMALL PLATFORM

TIRES

Standard – 135/155 10 x 16.5 - 8 PR Standard Track Flotation
Standard – 175/190/205 10 x 16.5 x 8 PR Wide Track Flotation
Available Options – Standard Track - Wide Track
 Lifemaster Industrial Pneumatic
 31.5 / 13 x 16.5 Extra Flotation
 Brawler
 Solid Industrial

Flotation tires are fitted for most applications.

*For arduous conditions and hostile environments solid tires are recommended.

TRACKS

All Track Models
 12.6 in (320 mm) traction lug

LARGE PLATFORM

TIRES

Standard – 225/260/280/300 12 x 16.5 - 10 PR
Standard – 330 14 x 17.5 x 10 PR
Available Options – Standard Track - Wide Track
 Lifemaster Industrial Pneumatic
 33 / 15.5 x 16.5 Extra Flotation
 Brawler
 Solid Industrial

Flotation tires are fitted for most applications.

*For arduous conditions and hostile environments solid tires are recommended.

TRACKS

225T/260T
 12.6 in (320 mm) traction lug
 17.7 in (450 mm) traction lug
300T/320T
 17.7 in (450 mm) traction lug



WEIGHT - SMALL PLATFORM

SAE Operating Weight

Fully operational with quickhitch, standard shovel, full fuel tank, open canopy + 165 lb (75 kg) operator:

135	6153 lb (2791 kg)	190	7054 lb (3200 kg)	150T	8137 lb (3691 kg)
155	6355 lb (2883 kg)	205	7297 lb (3310 kg)	190T	8355 lb (3790 kg)
175	6724 lb (3050 kg)			205T	8734 lb (3962 kg)

LIGHTING AND ELECTRICS - SMALL PLATFORM

12 V, negative ground system 1,000 cold cranking amp (CCA) battery

135	80 amp alternator	Cab mounted instrument panel with ignition, fuel gauge, hour meter, and electronic throttle
155 and Above	100 amp alternator	

Also incorporated into the instrument panel, is a warning light cluster which also has audible alarms for:

Low charge pressure	Blocked air filter
Engine water temperature	Engine oil pressure
Hydraulic oil pressure	Alternator

Cab mounted fuse and relay box designed to keep dirt and water out; IP 69 external connections; standard battery isolater.

STANDARD EQUIPMENT - ALL MODELS

Isolation mounted canopy. ROPS and FOPS. Full audible and visual warning systems. Restraint activated safety system. Loader arm safety strut. Centrifugal dry type engine air filter with safety element. Mechanical quickhitch. Electronic hand throttle. Two front and one rear worklight. Emergency lower valve. Fuel gauge. Hydraulic park brake. Standard Flow auxiliary hydraulics. Three way joysticks. Rear service access door. Tilting cab. Static seat in wheeled. Mechanical suspension in tracked. Float. Pod storage area. Cup holder. Power socket. Rear view mirror. Interior light. Battery isolater.

OPERATOR VISIBILITY

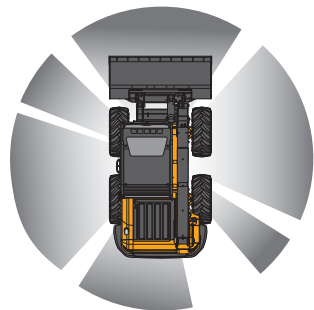

JCB
270° Visibility

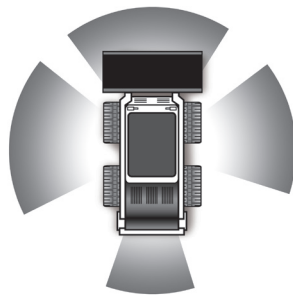

Typical Skid Steer
165° Visibility

- VISIBLE AREAS
- OBSTRUCTED AREAS

JCB's unique PowerBoom design makes our Skid Steer the world's safest and provides unmatched visibility.

WEIGHT - LARGE PLATFORM

SAE Operating Weight

Fully operational with quickhitch, standard shovel, full fuel tank, open canopy + 165 lb (75 kg) operator:

225	7954 lb (3608 kg)	300	9054 lb (4107 kg)	225T	10,216 lb (4634 kg)
260	8232 lb (3734 kg)	330	9354 lb (4243 kg)	260T	10,756 lb (4879 kg)
280	8368 lb (3796 kg)			300T	11,287 lb (5120 kg)
				320T	11,596 lb (5260 kg)

LIGHTING AND ELECTRICS - LARGE PLATFORM

12 V, negative ground system 1,000 cold cranking amp (CCA) battery

95 amp alternator	Cab mounted instrument panel with ignition, fuel gauge, hour meter, and electronic throttle
-------------------	---

Also incorporated into the instrument panel, is a warning light cluster which also has audible alarms for:

Low charge pressure	Blocked air filter
Engine water temperature	Engine oil pressure
Hydraulic oil pressure	Alternator

Cab mounted fuse and relay box designed to keep dirt and water out; IP 69 external connections; standard battery isolater.

OPTIONAL EQUIPMENT - ALL MODELS

Sealed and pressurized cab with heater/defroster. Air conditioning (155 and above). Mechanical and air suspension seats. Road lights. Beacon. Foot throttle. Fire extinguisher. Toolkit. Self leveling. Level 2 FOPS guard. Heavy-duty rear door guard. Front screen guard. High Flow auxiliary hydraulics (155 and above). Spark arrestor. Tooth guard. Powered quickhitch. Smooth Ride System (155 and above). Lexan screen. Radio. Twine cutter (wheeled units only). Three inch seat belt. Creep speed. ISO/H pattern changeover. Fenders. Reversing fan. Pre-cleaner.

OPERATOR ENVIRONMENT

Full ROPS and Level 1 FOPS with optional Level 2 FOPS guard for demolition, full audio and visual warning system. Soundproofing gives noise levels complying with EC regulations. Cab access through side door due to JCB's PowerBoom design.

- Deluxe environment available in either open canopy, cab with heat, or cab with heat and A/C (155 and Above)
- Unequaled all-around visibility.
- Fully adjustable seat.
- Retractable seat belt fitted as standard.
- Drainage cover for easy drainage of cab.
- Full servo control with either standard (3 way) joysticks or optional JCB multi-function (7-way) joysticks.

CONTROLS

JCB servo control (ISO) pattern, provides all drive functions on left and loader function on right joystick. The left hand control pod pivots rearwards, providing unparalleled machine entry / exit.



ATTACHMENTS

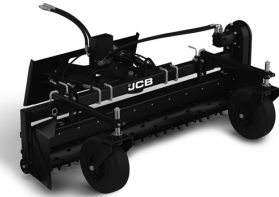
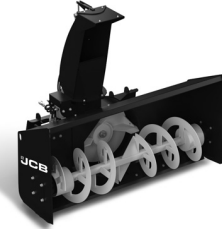

Attachment	Description
Augers	Planetary drive augers are built with fabricated boring heads using 1/2" thick plates with 5/8" carriage bolts and nuts.
Bale Spear	Utilized for picking up and carrying round bales of hay.
Breakers	JCB hammers are among the most efficient available and are perfectly matched to JCB equipment.
Brooms, Sweeper Collector	For general sweeping duties around the job site.
Brooms, Angle	JCB angle brooms cover many applications including site clean-up, landscape and ground maintenance, road work, and repair.
Brush Cutters	For removal of brush and small trees up to 4" in diameter.
Buckets, 6-in-1 Multipurpose	Genuine JCB 6-in-1 buckets are ideal for multiple applications such as digging, loading, dozing, grading, spreading, and grabbing.
Buckets, Dirt / General Purpose	Genuine JCB dirt / general purpose buckets are recommended where maximum breakout performance is required.
Buckets, Landscape	Genuine JCB landscape buckets are ideal when cutting edge visibility is important.
Buckets, Light Material	Genuine JCB light material buckets are specially designed for lower density materials such as snow, mulch, and grain.
Buckets, Snow	High carbon steel bucket with swept top wrap to better contain material.
Cold Planers	The JCB cold planer is a valuable tool for parking lot and street repairs in addition to many other uses.
Dozer Blades	The JCB dozer blade is an attachment that is suited for general grading and land clearing applications.
Forks, Pallet	Pallet forks are used in a variety of general forklift applications such as construction, industrial, and agricultural industries.

Attachment	Description
Forks, Manure	Provides excellent visibility while moving loose hay and manure.
Forestry Cutting Heads	Low profile with patent pending rotor design, rotor operates at 2000 rpm.
Grapples, Brush	Heavy-duty unit with open bottom and sides which allows machine to carry objects longer than unit width.
Grapples, Scrap	Heavy-duty unit with twin ram grapple and ram guard protection.
Rakes, Auto	JCB auto rake is used to groom and finish soil for sod or seed.
Rakes, Landscape Power	JCB landscape rakes are excellent tools for cleaning up debris, maintaining roads, driveways, and finish grading.
Rakes, Landscape Preparators	One solution for general clean-up, rock removal, and soil preparation.
Rock Saws	Available in 48" or 60" diameter for cutting rock and other hard surfaces.
Silage Defacers	Open design allows operator to see bucket face and keeps the attachment clog free.
Snow Blowers	Provides excellent visibility with 25" to 36" shroud opening.
Snow Blades	Available in various widths for removing snow.
Stump Grinders	Provides an environmentally friendly way to safely remove tree stumps.
Tillers	Provides for safe and efficient tilling with choice of 4" or 6" tilling depths.
Tree Spades	Provides safe and efficient removal and planting of trees.
Trenchers	The JCB trencher is useful for trenching footings, burying utilities, installing irrigation systems, etc.
Vibratory Rollers	Used to compact sand, gravel, soils, crushed stone, and other aggregates.



A GLOBAL COMMITMENT TO QUALITY

JCB's total commitment to its products and customers has helped it grow from a one-man business into one of the world's largest manufacturers of backhoe loaders, crawler excavators, wheeled excavators, telescopic handlers, wheeled loaders, dump trucks, rough terrain fork lifts, industrial fork lifts, mini/midi excavators, skid steer loaders and tractors.

By making constant and massive investments in the latest production technology, the JCB factories have become some of the most advanced in the world.

By leading the field in innovative research and design, extensive testing and stringent quality control, JCB machines have become renowned all over the world for performance, value and reliability.

And with an extensive dealer sales and service network in over 150 countries, we aim to deliver the best customer support in the industry.

Through setting the standards by which others are judged, JCB has become one of the world's most impressive success stories.



JCB Headquarters Savannah, 2000 Bamford Blvd, Savannah, GA 31322 Tel: (912) 447-2000 Fax: (912) 447-2299 www.jcb.com

JCB reserves the right to change design, materials and/or specifications without notice. Specifications are applicable to units sold in the United States and Canada. The JCB logo is a registered trademark of J C Bamford Excavators Ltd.