

## Standard Equipment

### ENGINE

- Engine, HINO J05E-UV, Diesel engine with turbocharger and intercooler
- Automatic engine deceleration
- Batteries (2 x 12V - 96Ah)
- Starting motor (24V - 5 kW), 50 amp alternator
- Removable clean-out screen for radiator
- Automatic engine shut-down for low engine oil pressure
- Engine oil pan drain cock
- Double element air cleaner

### CONTROL

- Working mode selector (H-mode, S-mode and ECO-mode)
- Heavy Lift and Power Boost "without time limit"

### SWING SYSTEM & TRAVEL SYSTEM

- Swing rebound prevention system
- Straight propel system
- Two-speed travel with automatic shift down
- Sealed & lubricated track links
- Grease-type track adjusters
- Automatic swing brake

### HYDRAULIC

- Arm regeneration system
- Auto warm up system
- Aluminum hydraulic oil cooler

### MIRRORS & LIGHTS

- Three rearview mirrors and rearview camera
- Two front working lights
- Swing flashers

## Optional Equipment

- Wide range of shoes
- Boom safety valve
- Arm safety valve

### CAB & CONTROL

- Two control levers, pilot-operated
- Horn, electric
- Integrated left-right slide-type control box
- Cab, all-weather sound suppressed type
- Ashtray
- Cigarette lighter
- Cab light (interior)
- Coat hook
- Luggage tray
- Large cup holder
- Detachable two-piece floor mat
- 7-way adjustable suspension seat
- Retractable seatbelt
- Headrest
- Handrails
- Heater and defroster
- Intermittent windshield wiper with double-spray washer
- Skylight
- Top guard
- Tinted safety glass
- Pull-type front window and removable lower front window
- Easy-to-read multi-display monitor
- Automatic air conditioner
- Emergency escape hammer
- Radio, AM/FM Stereo with speakers
- Travel alarm
- Drain pressure switch
- DPF regeneration switch

- Front-guard protective structures
- Additional hydraulic circuit
- Control pattern changer (2-way)

Note: This catalog may contain attachments and optional equipment that are not available in your area. And it may contain photographs of machines with specifications that differ from those of machines sold in your areas. Please consult your nearest KOBELCO distributor for those items you require. Due to our policy of continuous product improvements all designs and specifications are subject to change without advance notice.

Copyright by **KOBELCO CONSTRUCTION MACHINERY CO., LTD.** No part of this catalog may be reproduced in any manner without notice.

## KOBELCO CONSTRUCTION MACHINERY CO., LTD.

17-1, Higashigotanda 2-chome, Shinagawa-ku, Tokyo 141-8626 JAPAN  
Tel: +81 (0) 3-5789-2146 Fax: +81 (0) 3-5789-2135  
[www.kobelco-kenki.co.jp/english\\_index.html](http://www.kobelco-kenki.co.jp/english_index.html)

Inquiries To:

Bulletin No. SK350LC-9-NA-101

2013030000E Printed in USA

# KOBELCO

## Hydraulic Excavators

# SK350 LC

**We Save You Fuel**  
Achieving a Low-Carbon Society

### ■ Bucket Capacity :

1.57 - 2.09 cu.yd. SAE

### ■ Engine Power :

270 hp {201 kW} / 2,100 rpm{min<sup>-1</sup>}  
(ISO9249)

### ■ Operating Weight :

81,800 lbs {37,100 kg}



Complies with the latest exhaust emission regulations



US  
EPA Tier IV



EU (NRM)  
Stage IIIB



Japanese  
Regulations

# The Power Wave of Change

Introducing a new generation of hydraulic excavators that provide the three E's: Enhancement, Economy and Environment!

The refining of each of these "E's", together with the introduction of leading-edge technology that complies with US EPA Tier 4 emission standards provides excavators with even more enhanced environmental performance and fuel efficiency, as well as unparalleled work performance.

The incredible work rate of these excavators is provided by powerful digging strength and a wide digging range. These excavators feature a new engine model with reduced environmental impact and Kobelco's unique technology that reduces pressure-loss resistance.

Kobelco's reliable and well-tested technology has been developed over many years, making it more than capable of satisfying the various demands of today's construction industry.

Continuously creating original value, Kobelco has been able to bring technical marvels into existence through a spirit of perpetual pursuit.



## Enhancement

### Greater Performance Capacity

- Reduced fuel consumption with highly efficient productivity
- New environmental engine with superior fuel efficiency and low fuel consumption hydraulic circuitry
- Powerful arm bucket digging strength and wide digging range

## Economy

### Improved Cost Efficiency

- Adoption of new "ECO-Mode" greatly reduces fuel consumption
- Easy maintenance that reduces upkeep costs
- High structural durability and reliability that retain machine value longer

## Environment

### Features That Go Easy on the Earth

- Compliance with US EPA Tier IV regulations
- Low-noise and low vibration including improvements to sound quality

### Fuel Consumption Rate

(Comparison with Previous Model in S-Mode/Eco-Mode)

- about **25%**

### PM Reduction Rate

- about **88%**

### Digging Volume per Liter of Fuel

(Comparison with Previous Model in S-Mode/Eco-Mode)

+ about **23%**

# More Work with Less Fuel !!

## Top-Class Powerful Digging (SAE J 1179:1990)

- Max. arm crowding force: **37,100 lbs {160kN}**
- Max. arm crowding force with power boost: **39,600 lbs {176kN}**
- Max. bucket digging force: **44,700 lbs {199kN}**
- Max. arm crowding force with power boost: **49,200 lbs {219kN}**

## Great Swing Power, Short Cycle Times

- Swing speed: **10.0 rpm {10.0min<sup>-1</sup>}**

## Powerful Travel

- Drawbar pulling force: **72,200 lbs {321kN}**

## Digging Volume per Liter of Fuel

(Comparison with Previous Model in S-Mode/Eco-Mode)

+ about **23%**

H-Mode : + about **16%**

S-Mode : + about **12%**

## Energy Saving System

### Fuel Consumption Rate

(Comparison with Previous Model in S-Mode/Eco-Mode)

- about **25%**

### Hydraulic Circuit with Reduced Energy Loss

The KOBELCO original hydraulic circuit analysis is used to construct the hydraulic system with extremely reduced energy loss that contains a piping design for small abrasion resistance and the minimum valve resistance.



### ECO-Mode

The ECO-mode is newly provided in this machine. The synergistic effect with the engine, etc. makes this mode possible to significantly reduce fuel consumption. The each mode for each work and circumstance can be selected easily from the switch.

### Each Mode Reduces Fuel Consumption (Comparison with Previous Model)



**H** H-Mode about **16% ↓**  
Suitable for a heavy workload

**S** S-Mode about **11% ↓**  
Suitable for a good balance between workload and fuel consumption

**NEW E** ECO-Mode about **15% ↓**  
Suitable for a severe priority on low fuel consumption at a light workload

## New Eco-Friendly Engine

### PM Reduction Rate

- about **88%**

### Newly Developed Engine

HINO engine establishes reputation on low fuel consumption and its environmental performance. This machine adopts HINO engine and KOBELCO tunes it with the original method. The common knowledge of ecology will be changed by this new type eco-friendly engine.



### PM emissions cut: Limits creation of particulate matter (which results from incomplete combustion of fuel)

■ Common rail system  
High-pressure injection atomizes the fuel, and injection timing is more precise, improving combustion efficiency.

■ VG turbo  
The opening of the exhaust side nozzles in the variable-geometry turbocharger adjusts air intake to maximize combustion efficiency. At low engine speeds the nozzles are closed, then the turbo speed is increased and air intake is boosted. This helps lower fuel consumption.

■ Diesel Particulate Filter (DPF)  
Carbon is built up as soot on the diesel particulate filter and is burned off at high temperature. At low engine speeds the exhaust temperature is too low, and the common rail multiple injection system is then operated to raise the temperature sufficiently to burn off the soot.

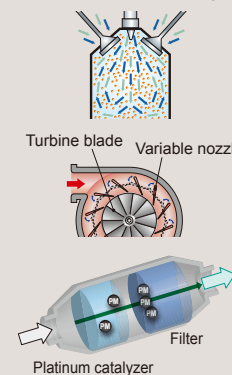

### NOx emissions cut: Reduces nitrogen oxides (created by reaction with oxygen at high temperature)

■ EGR cooler  
While ensuring sufficient oxygen for combustion, cooled emission gases are mixed with the air intake and re-circulated into the engine. Then the oxygen concentration is lowered and the combustion temperature is lowered.

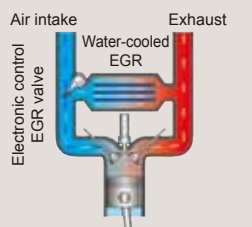

## Color Multi-Display

The easy-to-read liquid crystal color multi-display, which has vivid colors and graphical indications, is provided at the new type console. Not only the each machine information such as fuel consumption and maintenance, but also the picture of the rearward visibility monitoring camera is appeared on the display.



Maintenance Information Display



Fuel Consumption Gauge Display



Camera Display



The instantly understandable analogue gauge for fuel level and engine coolant temperature.

The green lamp lights on at the low fuel consumption operation.

The display can be switched to the fuel consumption / picture of rearward visibility monitoring camera display.

Each switch such as the work mode select switch is gathered here.

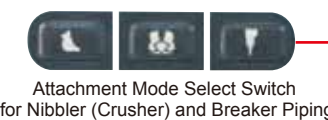

Attachment Mode Select Switch for Nibbler (Crusher) and Breaker Piping

# Designed from the Operator's Point of View

## Comfortability

### Big Cab

The "Big cab" provides a roomy operating space with plenty of legroom, and the door opens wide for entry and exit. As well as giving a wide, open view to the front, the cab has increased window areas on both sides and to the rear, for improved visibility in all directions.



### Excellent Visibility

Taking out the right-side cab support to make a single window has improved visibility to the right.

- Taking out the right-side cab support to make a single window has improved wide visibility.
- The view is not obstructed by the provided rise up wiper when the wiper is not used.
- Safety check is easy with the left and right rearview mirrors, right lower mirror, and rearward visibility monitoring camera.
- The tempered green glass complied with European Standards is adopted.

## Safety

### ROPS Cab

The newly developed, ROPS (Roll-Over -Protective Structure)-compliant cab clears ISO standards(ISO-12117 -2: 2008) and ensures greater safety for the operator should the machine tip over.



● FOPS guard



- Level 2 FOPS Guard (ISO 10262) is equipped as standard.
- To fit vandalism guards, please contact your KOBELCO dealer. (Mounting brackets for vandalism guards)

### Wide-Access Cab Helps Smooth Entry and Exit

Easy entry and exit assured with wider cab entry and safety lock lever integrated with mounting for control levers.



### Comfortable Operating Environment

The inside of the cab is fully equipped for operator comfort. For example, the seat is comfortable when operating the machine and also when relaxing in the cab. The large storage space is provided. All of them are designed with operator comfort as the first priority in mind.



Reclining seat



Double slide seat



Powerful automatic air conditioner



Two-speaker FM/AM radio with station select



Large cup holder



Spacious luggage tray

### Rear View Camera

By the picture of the rearward visibility monitoring camera, safety checks for rearward visibility can be carried out easily. The camera is provided as a standard specification and the operation visibility is complied with ISO standards. The picture of it is appeared on the color multi-display.



### Safety Features That Take Various Scenarios into Consideration



● Firewall separates the pump compartment from the engine



● Swing flashers / rear working lights



● Hammer for emergency exit

- Hand rails are complied with European Standards
- Thermal guard prevents contact with hot components during engine inspections
- Travel alarm
- Retractable seatbelt requires no manual adjustment

# The Value and Quality of Sturdy Construction!



## Attachment and Body Structure Designed for High Strength

The forged and cast steel materials are applied to the attachment stress concentration part on the arm and boom. This is one of the securing high stress measures applied to this machine in various ways. Also the body structure such as the bottom of the upper frame and the side deck are designed for high strength to secure reliable high durability.

## Quality of Durability

The high quality urethane paint is applied to the machine body to keep the machine body beautiful for a long time. The bolt up handrail is attached to the cab for an easy repair and the high durability surface material is used on the operator's seat inside the cab.



## 500 Hours Cycle of Attachment Lubrication

The self lubrication bushings are used at the attachment pins and the bushings with high abrasion resistant property are used at the pins around the bucket. The lubrication cycle of the lubrication points around the bucket is 250 hours and that of other lubrication points is 500 hours.



## New-Design Fuel Filter Catches 95% of Dust and Impurities

The large-capacity fuel filter is designed specifically for common rail engines. With an increased filtering performance to 2-micron precision, this high-grade filter catches 95% of all dust particles and other impurities in the fuel.



## Long-Life Hydraulic Oil Reduces Replacement Costs

The long-life hydraulic oil features a base oil with excellent demulsification, with optimized wear-resistant additives and antioxidants that help to boost the service life to 5,000 hours and greatly reduce the number of changes necessary.

Long-life hydraulic oil  
**5,000** hours

## Highly Durable Super-fine Filter

The high-capacity hydraulic oil filter incorporates glass fiber with superior cleaning power and durability. With a replacement cycle of 1,000 hours and a construction that allows replacement of the filter element only, it is both highly effective and highly economical.



Super-fine filter

## Double-Element Air Cleaner as Standard

The large-capacity element features a double-filter structure that keeps the engine running clean even in dusty environments.

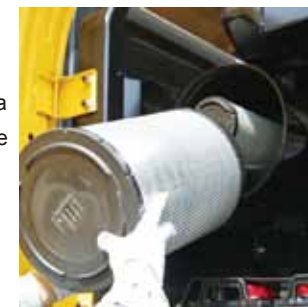

## Emergency Acceleration (Dial) Permits Continued Operation in the Unlikely Event of Malfunction



If unexpected trouble is experienced with the ITCS mechatronic control system, the machine can still be operated using the emergency acceleration system. Digging modes are also automatically relayed to an emergency system so that digging can continue temporarily until a service person arrives to repair the primary system.

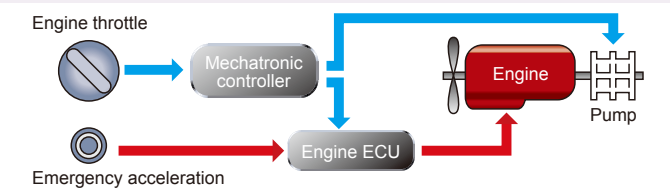

## Newly designed MCU



New MCU Conventional MCU

- Vertical alignment and sealed cover gives better protection from water and dust
- Integration in base plate boosts assembly quality
- Reliable fixture to base plate

## Countermeasures Against Electrical System Failure

All elements of the electrical system, including controller, have been designed for enhanced reliability.

# Fast, Accurate and Low-Cost Maintenance



## Machine Information Display Function Is Essential for Accurate Maintenance

- When necessary, only the maintenance required item is displayed by the maintenance information display function.
- Malfunction at the electrical system is detected and displayed in the early stage by the self-diagnostic function.
- The machine condition can be easily checked by the service diagnosis function.
- Malfunction including irregular and transient one can be checked by the trouble history record function.



- Engine Oil Exchange
- Fuel Filter Exchange
- Hydraulic Oil Filter Exchange
- Hydraulic Oil Exchange

## Maintenance from the Ground with Comfortable Working Posture

The components and parts those are subjected to be checked in daily inspection and periodic maintenance are provided at the accessible positions from the ground. This machine is designed with easy inspection and maintenance in mind.



Air Cleaner (double element)



Fuel Filter (with built-in water separator)



Engine Oil Filter



Handrails



Three Steps

## Safety Maintenance from the Machine

The steps to the machine upper surface become three steps and the handrail complied with ISO standards is adopted. These are provided for safety maintenance from the machine.

## Easy-to-Access Inside Cab Helps Easy Inspection



Fuse Box



DPF Manual Regeneration Switch



Hour Meter



Air Conditioner Filter

## Easy-to-Clean Parts Shorten the Cleaning Time



Crawler Frame



Floor Mat



Fuel Drain Valve

## Total Support for Machines with Network Speed and Accuracy

Our "Machine Operation Management System" allows you to use the Internet to manage information from your office for machines operating in all areas. Be prepared for any problems with strategic information and cost management. This provides a wide range of support for your business operations.

### Direct Access to Operational Status

#### Location Data

Accurate location data can be obtained even from sites where communications are difficult.

#### Operating Hours

A comparison of operating times of machines at multiple locations shows which locations are busier and more profitable. Operating hours on site can be accurately recorded, for running time calculations needed for rental machines, etc.

#### Fuel Consumption Data

Data on fuel consumption and idling times can be used to indicate improvements in fuel consumption.

#### Graph of Work Content

The graph shows how working hours are divided among different operating categories, including digging, idling, traveling, and optional operations (N&B).



### Maintenance Data and Warning Alerts

#### Machine Maintenance Data

Provides maintenance status of separate machines operating at multiple sites. Maintenance data is also relayed to KOBELCO service personnel, for more efficient planning of periodic servicing.

### Security System

#### Engine Start Alarm

The system can be set an alarm if the machine is operated outside the designated time.

#### Area Alarm

It can be set an alarm if the machine is moved out of its designated area to another location.

## Engine

Model	HINO J08E-UV
<b>Type:</b>	Direct injection, water-cooled, 4-cycle diesel engine with turbocharger, intercooler (Complies with EU (NRMM) Stage IIIB, EPA Tier IV, and act on regulation, etc. of emission from non- road special motor vehicles (Japan))
<b>No. of cylinders:</b>	6
<b>Bore and stroke:</b>	4.41" (112 mm) x 5.12" (130 mm)
<b>Displacement:</b>	469 cu.in (7.684 L)
<b>Rated power output:</b>	286hp {213 kW} / 2,100 rpm {min <sup>-1</sup> } (ISO 14396) 270hp {201 kW} / 2,100 rpm {min <sup>-1</sup> } (ISO 9249)
<b>Max. torque:</b>	750 lb-ft {1,017 N·m} / 1,600 rpm {min <sup>-1</sup> } (ISO 14396) 736 lb-ft {998 N·m} / 1,600 rpm {min <sup>-1</sup> } (ISO 9249)

## Hydraulic System

Pump	
<b>Type:</b>	Two variable displacement pumps + 1 gear pump
<b>Max. discharge flow:</b>	2 x 77.7 U.S.gph {2 x 294 L/min}, 1 x 5.3 U.S.gph {1 x 20 L/min}
Relief valve setting	
<b>Boom, arm and bucket:</b>	4,970 psi {34.3 Mpa}
<b>Power Boost:</b>	5,480 psi {37.8 Mpa}
<b>Travel circuit:</b>	4,970 psi {34.3 Mpa}
<b>Swing circuit:</b>	4,210 psi {29.0 Mpa}
<b>Control circuit:</b>	725 psi {5.0 Mpa}
<b>Pilot control pump:</b>	Gear type
<b>Main control valves:</b>	8-spool
<b>Oil cooler:</b>	Air cooled type

## Swing System

<b>Swing motor:</b>	Axial piston motor
<b>Brake:</b>	Hydraulic; locking automatically when the swing Control lever is in neutral position
<b>Parking brake:</b>	Hydraulic disc brake
<b>Swing speed:</b>	10.0 rpm {min <sup>-1</sup> }
<b>Tail swing radius:</b>	11'6" {3,500 mm}
<b>Min. front swing radius:</b>	14'4" {4,370 mm}

## Attachments

Backhoe bucket and arm combination

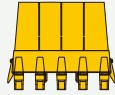
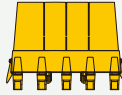
Use	Backhoe bucket			
				
<b>Bucket capacity</b>	<b>SAE heaped</b> cu.yd.{m <sup>3</sup> }	1.57 {1.2}	1.83 {1.40}	2.09 {1.60}
	<b>SAE Struck</b> cu.yd.{m <sup>3</sup> }	1.10 {0.84}	1.31 {1.00}	1.57 {1.20}
<b>Opening width</b>	<b>With side cutter</b> inches {mm}	49 {1,240}	56 {1,420}	62 {1,570}
	<b>Without side cutter</b> inches {mm}	44 {1,110}	55 {1,390}	57 {1,450}
<b>No. of bucket teeth</b>	4	5	5	
<b>Bucket weight</b> lbs {kg}	2,050 {930}	2,380 {1,080}	2,510 {1,140}	
<b>Combinations</b>	<b>8'6" {2.6 m} short arm</b>	○	○	⊙
	<b>10'10" {3.3 m} standard arm</b>	○	⊙	△
	<b>13'7" {4.15 m} long arm</b>	○	△	×

○ Standard ○ Recommended △ Loading only × Not recommended

## Travel System

<b>Travel motors:</b>	2 x axial-piston, two-step motors
<b>Travel brakes:</b>	Hydraulic disc brake
<b>Parking brakes:</b>	Oil disc brake per motor
<b>Travel shoes:</b>	48 each side
<b>Travel speed:</b>	3.5 / 2.0 mph {5.6 / 3.3 km/h}
<b>Drawbar pulling force:</b>	72,200 lbs {321 kN} (SAE J 1309)
<b>Gradeability:</b>	70 % {35°}
<b>Ground clearance:</b>	19.7" (500 mm)

## Cab & Control

Cab	
All-weather, sound-suppressed steel cab mounted on the silicon-sealed viscous mounts and equipped with a heavy, insulated floor mat.	
Control	
Two hand levers and two foot pedals for travel	
Two hand levers for excavating and swing	
Electric rotary-type engine throttle	

## Boom, Arm & Bucket

<b>Boom cylinder:</b>	5.5" {140 mm} x 5'1" {1,550 mm}
<b>Arm cylinder:</b>	6.7" {170 mm} x 5'10" {1,788 mm}
<b>Bucket cylinder:</b>	5.9" {150 mm} x 3'11" {1,193 mm}

## Refilling Capacities & Lubrications

<b>Fuel tank:</b>	153.2 U.S.gal {580 L}
<b>Cooling system:</b>	7.6 U.S.gal {28.9 L}
<b>Engine oil:</b>	7.5 U.S.gal {28.5 L}
<b>Travel reduction gear:</b>	2 x 2.5 U.S.gal {2 x 9.5 L}
<b>Swing reduction gear:</b>	2.0 U.S.gal {7.4 L}
<b>Hydraulic oil tank:</b>	64.7 U.S.gal {245 L} tank oil level 109.1 U.S.gal {413 L} hydraulic system

## Working Ranges

Unit: ft-in {m}

Range	Boom	21'4" {6.50m}		
		Short 8'6" {2.6 m}	Standard 10'10" {3.30 m}	Long 13'7" {4.15 m}
<b>a- Max. digging reach</b>		34'10" {10.61}	36'11" {11.26}	39'3" {11.97}
<b>b- Max. digging reach at ground level</b>		34'1" {10.40}	36'3" {11.06}	38'8" {11.79}
<b>c- Max. digging depth</b>		22'6" {6.86}	24'10" {7.56}	27'7" {8.41}
<b>d- Max. digging height</b>		33'8" {10.26}	34'9" {10.58}	35'1" {10.70}
<b>e- Max. dumping clearance</b>		23'2" {7.06}	24'2" {7.37}	24'8" {7.53}
<b>f- Min. dumping clearance</b>		10'11" {3.32}	8'7" {2.62}	5'10" {1.77}
<b>g- Max. vertical wall digging depth</b>		19'2" {5.84}	21'8" {6.61}	23'5" {7.15}
<b>h- Min. swing radius</b>		14'7" {4.45}	14'4" {4.37}	14'6" {4.43}
<b>i- Horizontal digging stroke at ground level</b>		21'11" {6.67}	19'1" {5.82}	27'2" {8.27}
<b>j- Digging depth for 8 feet flat bottom</b>		13'10" {4.21}	24'3" {7.40}	28'8" {7.21}
<b>Bucket capacity SAE heaped cu.yd.{m<sup>3</sup>}</b>		2.09 {1.60}	1.83 {1.40}	1.57 {1.20}

## Digging Force

Unit: lbs {kN}

Arm length	21'4" {6.50m}			
	Short 8'6" {2.6 m}	Standard 10'10" {3.30 m}	Long 13'7" {4.15 m}	
<b>Bucket digging force</b>	SAE	44,700 {199} 49,200 {219}*	44,700 {199} 49,200 {219}*	44,500 {198} 49,000 {218}*
	ISO	49,700 {221} 54,900 {244}	49,900 {222} 54,900 {244}*	49,700 {221} 54,600 {243}*
<b>Arm crowding force</b>	SAE	44,500 {198} 49,000 {218}*	37,100 {160} 39,600 {176}*	30,800 {137} 33,700 {150}*
	ISO	46,100 {205} 50,600 {225}*	37,100 {165} 40,700 {181}*	31,500 {140} 34,600 {154}*

\* Power Boost engaged.

## Dimensions

Arm length	Short 8'6" {2.6 m}	Standard 10'10" {3.30m}	Long 13'7" {4.15 m}
<b>A Overall length</b>	37'1" {11,300}	36'9" {11,200}	36'9" {11,200}
<b>B Overall height (to top of boom)</b>	11'11" {3,640}	11'3" {3,420}	11'9" {3,590}
<b>C Overall width</b>	11'1" {3,390}		
<b>D Overall height (to top of cab)</b>	10'6" {3,210}		
<b>E Ground clearance of rear end*</b>	3'11" {1,190}		
<b>F Ground clearance*</b>	19.7" {500}		

Unit: ft-in{mm}

<b>G Tail swing radius</b>	11'6" {3,500}
<b>G' Distance from center of swing to rear end</b>	11'6" {3,500}
<b>H Tumbler distance</b>	13'3" {4,050}
<b>I Overall length of crawler</b>	16'3" {4,960}
<b>J Track gauge</b>	8'6" {2,590}
<b>K Shoe width</b>	23.6" {600} / 27.6" {700} / 31.5" {800} / 35.4" {900}
<b>L Overall width of upperstructure</b>	9'9" {2,980}

\* Without including height of shoe lug

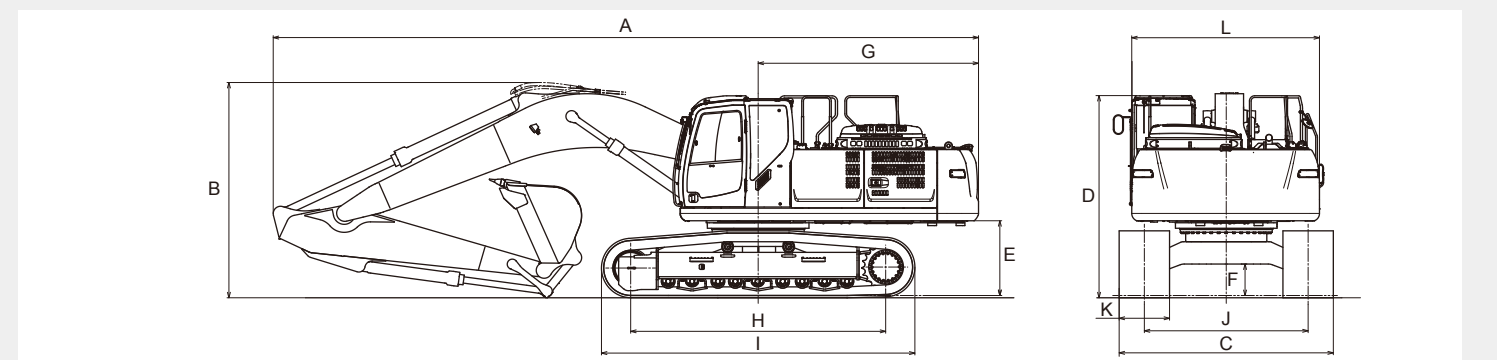

## Operating Weight & Ground Pressure

In standard trim, with standard boom, 10'10" {3.30m} arm, and 1.83 cu.yd. {0.83m<sup>3</sup>} SAE heaped bucket

Shaped	Triple grouser shoes (even height)			
<b>Shoe width</b> ft-in{mm}	23.6" {600}	27.6" {700}	31.5" {800}	35.4" {900}
<b>Overall width of crawler</b> ft-in{mm}	10'6" {3,190}	10'10" {3,290}	11'1" {3,390}	11'5" {3,490}
<b>Ground pressure</b> psi {kPa}	9.7 {67}	8.4 {58}	7.5 {52}	6.7 {46}
<b>Operating weight</b> lbs {kg}	78,500 {35,600}	80,000 {36,300}	80,900 {36,700}	81,800 {37,100}

## Lifting Capacities

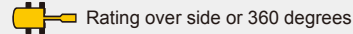
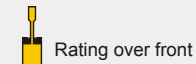
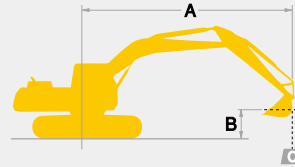

A – Reach from swing centerline for bucket hook  
 B – Bucket hook height above/below ground  
 C – Lifting capacities in kilograms

SK350LC		Standard Arm: 10'10" {3.30m} Bucket: 1.83cu.yd. {1.40m <sup>3</sup> } SAE heaped 2,380lbs {1,080kg} Shoe: 31'5" {800mm}														
B	A	5' {1.5m}		10' {3.0m}		15' {4.6m}		20' {6.1m}		25' {7.6m}		30' {9.1m}		At Max. Reach		Radius
		Rating over front	Rating over side or 360 degrees	Rating over front	Rating over side or 360 degrees	Rating over front	Rating over side or 360 degrees	Rating over front	Rating over side or 360 degrees	Rating over front	Rating over side or 360 degrees	Rating over front	Rating over side or 360 degrees	Rating over front	Rating over side or 360 degrees	
25' {7.6m}	lb(kg)															
20' {6.1m}	lb(kg)															
15' {4.6m}	lb(kg)															
10' {3.0m}	lb(kg)															
5' {1.5m}	lb(kg)															
G.L.	lb(kg)															
-5' {-1.5m}	lb(kg)															
-10' {-3.0m}	lb(kg)															
-15' {-4.6m}	lb(kg)															
-20' {-6.1m}	lb(kg)															

SK350LC		Standard Arm: 10'10" {3.30m} Bucket: 1.83cu.yd. {1.40m <sup>3</sup> } SAE heaped 2,380lbs {1,080kg} Shoe: 31'5" {800mm} <b>HEAVY LIFT</b>														
B	A	5' {1.5m}		10' {3.0m}		15' {4.6m}		20' {6.1m}		25' {7.6m}		30' {9.1m}		At Max. Reach		Radius
		Rating over front	Rating over side or 360 degrees	Rating over front	Rating over side or 360 degrees	Rating over front	Rating over side or 360 degrees	Rating over front	Rating over side or 360 degrees	Rating over front	Rating over side or 360 degrees	Rating over front	Rating over side or 360 degrees	Rating over front	Rating over side or 360 degrees	
25' {7.6m}	lb(kg)															
20' {6.1m}	lb(kg)															
15' {4.6m}	lb(kg)															
10' {3.0m}	lb(kg)															
5' {1.5m}	lb(kg)															
G.L.	lb(kg)															
-5' {-1.5m}	lb(kg)															
-10' {-3.0m}	lb(kg)															
-15' {-4.6m}	lb(kg)															
-20' {-6.1m}	lb(kg)															

SK350LC		Short Arm: 8'6" {2.60m} Bucket: 2.09 cu.yd. {1.60 m <sup>3</sup> } SAE heaped 2,510lbs {1,140kg} Shoe: 31'5" {800 mm}										
B	A	10' {3.0m}		15' {4.6m}		20' {6.1m}		25' {7.6m}		At Max. Reach		Radius
		Rating over front	Rating over side or 360 degrees	Rating over front	Rating over side or 360 degrees	Rating over front	Rating over side or 360 degrees	Rating over front	Rating over side or 360 degrees	Rating over front	Rating over side or 360 degrees	
25' {7.6m}	lb(kg)											
20' {6.1m}	lb(kg)											
15' {4.6m}	lb(kg)											
10' {3.0m}	lb(kg)											
5' {1.5m}	lb(kg)											
G.L.	lb(kg)											
-5' {-1.5m}	lb(kg)											
-10' {-3.0m}	lb(kg)											
-15' {-4.6m}	lb(kg)											

SK350LC		Short Arm: 8'6" {2.60m} Bucket: 2.09 cu.yd. {1.60 m <sup>3</sup> } SAE heaped 2,510lbs {1,140kg} Shoe: 31'5" {800 mm} <b>HEAVY LIFT</b>										
B	A	10' {3.0m}		15' {4.6m}		20' {6.1m}		25' {7.6m}		At Max. Reach		Radius
		Rating over front	Rating over side or 360 degrees	Rating over front	Rating over side or 360 degrees	Rating over front	Rating over side or 360 degrees	Rating over front	Rating over side or 360 degrees	Rating over front	Rating over side or 360 degrees	
25' {7.6m}	lb(kg)											
20' {6.1m}	lb(kg)											
15' {4.6m}	lb(kg)											
10' {3.0m}	lb(kg)											
5' {1.5m}	lb(kg)											
G.L.	lb(kg)											
-5' {-1.5m}	lb(kg)											
-10' {-3.0m}	lb(kg)											
-15' {-4.6m}	lb(kg)											

SK350LC		Long Arm: 13'7" {4.15m} Bucket: 1.57 cu.yd. {1.20m <sup>3</sup> } SAE heaped 2,050lbs {930kg} Shoe: 31'5" {800mm}														
B	A	5' {1.5m}		10' {3.0m}		15' {4.6m}		20' {6.1m}		25' {7.6m}		30' {9.1m}		At Max. Reach		Radius
		Rating over front	Rating over side or 360 degrees	Rating over front	Rating over side or 360 degrees	Rating over front	Rating over side or 360 degrees	Rating over front	Rating over side or 360 degrees	Rating over front	Rating over side or 360 degrees	Rating over front	Rating over side or 360 degrees	Rating over front	Rating over side or 360 degrees	
25' {7.6m}	lb(kg)															
20' {6.1m}	lb(kg)															
15' {4.6m}	lb(kg)															
10' {3.0m}	lb(kg)															
5' {1.5m}	lb(kg)															
G.L.	lb(kg)															
-5' {-1.5m}	lb(kg)															
-10' {-3.0m}	lb(kg)															
-15' {-4.6m}	lb(kg)															
-20' {-6.1m}	lb(kg)															

SK350LC		Long Arm: 13'7" {4.15m} Bucket: 1.57 cu.yd. {1.20m <sup>3</sup> } SAE heaped 2,050lbs {930kg} Shoe: 31'5" {800mm} <b>HEAVY LIFT</b>														
B	A	5' {1.5m}		10' {3.0m}		15' {4.6m}		20' {6.1m}		25' {7.6m}		30' {9.1m}		At Max. Reach		Radius
		Rating over front	Rating over side or 360 degrees	Rating over front	Rating over side or 360 degrees	Rating over front	Rating over side or 360 degrees	Rating over front	Rating over side or 360 degrees	Rating over front	Rating over side or 360 degrees	Rating over front	Rating over side or 360 degrees	Rating over front	Rating over side or 360 degrees	
25' {7.6m}	lb(kg)															
20' {6.1m}	lb(kg)															
15' {4.6m}	lb(kg)															
10' {3.0m}	lb(kg)															
5' {1.5m}	lb(kg)															
G.L.	lb(kg)															
-5' {-1.5m}	lb(kg)															
-10' {-3.0m}	lb(kg)															
-15' {-4.6m}	lb(kg)															
-20' {-6.1m}	lb(kg)															

### Notes:

- Do not attempt to lift or hold any load that is greater than these lift capacities at their specified lift point radius and heights. Weight of all accessories must be deducted from the above lift capacities.
- Lift capacities are based on machine standing on level, firm, and uniform ground. User must make allowance for job conditions such as soft or uneven ground, out of level conditions, side loads, sudden stopping of loads, hazardous conditions, experience of personnel, etc.
- Bucket lift hook is defined as lift point.
- The above lifting capacities are in compliance with SAE J/ISO 10567. They do not exceed 87 % of hydraulic lifting capacity or 75 % of tipping load. Lifting capacities marked with an asterisk (\*) are limited by hydraulic capacity rather than tipping load.
- Operator should be fully acquainted with the Operator's and Maintenance Instructions before operating this machine. Rules for safe operation of equipment should be adhered to at all times.
- Lift capacities apply to only machines as originally manufactured and normally equipped by KOBELCO CONSTRUCTION MACHINERY CO., LTD.