

REVISIONS				
ZONE	REV.	DESCRIPTION	DATE	APPROVED

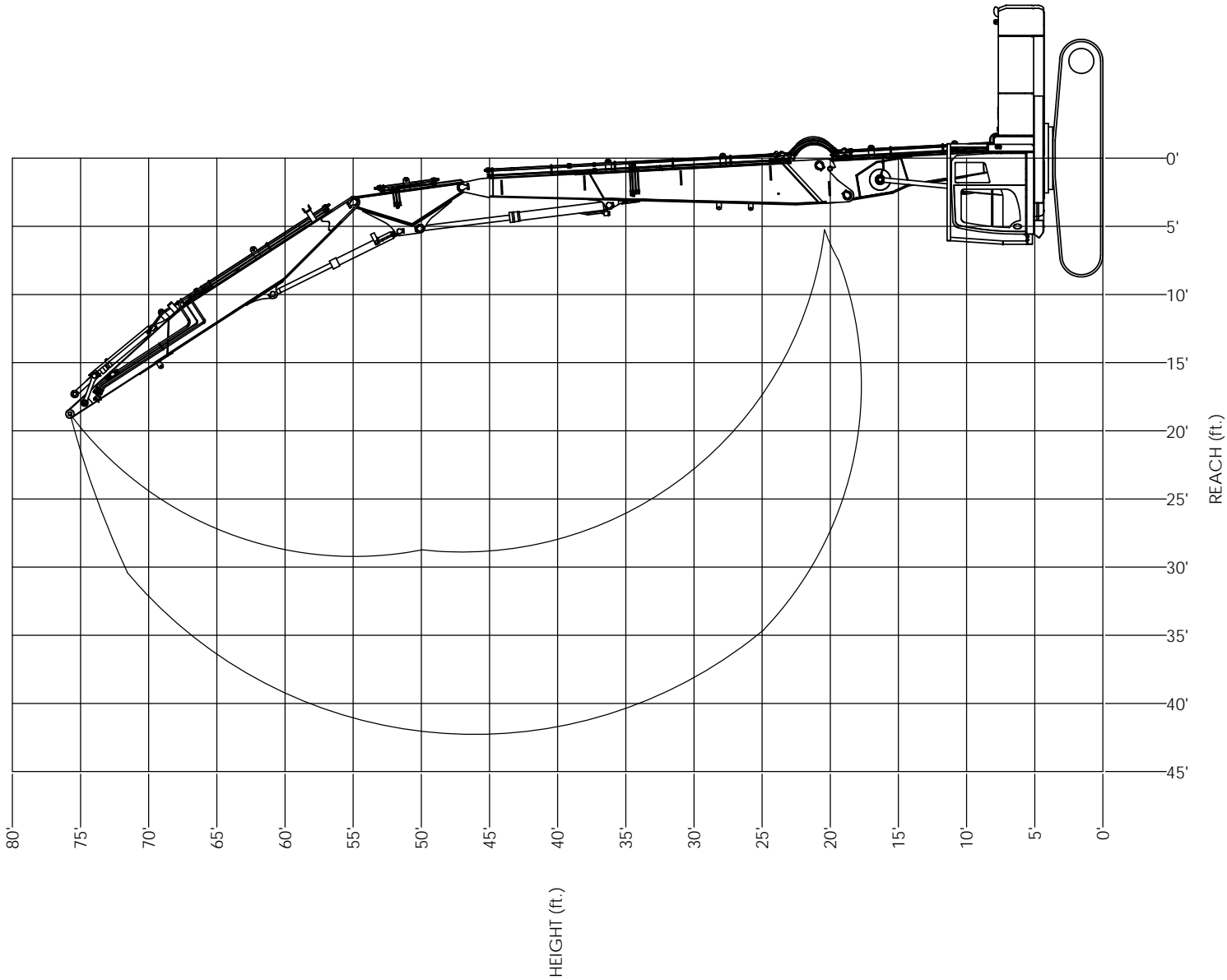

Based on SAE Standard No. J1097

MATERIAL:		



4805 SCOOPY LANE NW  
CARROLL, OHIO 43112  
740-654-5304

*The Cutting Edge of Customer Service*

PROFESSIONAL AND CONFIDENTIAL  
THE INFORMATION CONTAINED HEREIN  
DRAWING IS THE SOLE PROPERTY OF  
COMPANY WRENCH. ANY REPRODUCTION  
WITHOUT THE WRITTEN PERMISSION OF  
COMPANY WRENCH IS PROHIBITED.

UNLESS OTHERWISE SPECIFIED  
DIMENSIONS FOR DIMENSIONS ARE  
AS FOLLOWS:  
DECIMAL: .0001"  
FRACTIONAL: 1/16"  
ANGULAR: .1°  
WEIGHT:  

TITLE:	PC390LC-10 75' RANGE
SCALE: 1:45	SIZE: D
DWG./PART NO.	OM11026-3
SHEET 1 OF 1	



**WARNING:** DO NOT OPERATE MACHINE OVER SIDE. OPERATE OVER FRONT ONLY WITH DRIVES TO THE REAR OF THE MACHINE.

Lift capacities calculated at attachment pivot point on stick (lbs).  
No attachment on stick. Attachment weight must be subtracted.

REACH								HEIGHT
45'	40'	35'	30'	25'	20'	15'	10'	
					* 18,707			75'
			* 11,138	* 14,311				70'
		* 8,966	* 11,089					65'
		* 8,934	* 11,360					60'
	* 7,307	* 8,882	* 11,433					55'
	* 7,275	* 8,847	* 11,371					50'
	* 7,237	* 8,796	* 11,198					45'
	* 7,193	* 8,745	* 10,958					40'
	* 7,140	* 8,706	* 10,735					35'
		* 8,658	* 10,661	* 13,436				30'
			* 10,599	* 13,357	* 17,415			25'
				* 13,184	* 17,327	* 24,264	* 38,380	20'
					* 16,697			15'
					* 15,485			10'
					* 10,925			5'
					* 8,869			0'

The following notes pertain to this machine equipped with 35.5" wide track pads:

1. Do not attempt to lift or hold any load that exceeds these rated values.
2. When working, the boom must be in the fully upright position. Maximum forward tilt of boom is 10 degrees.
3. Machine must never be operated over the side.
4. The operator should be fully acquainted with machine operation before operating the machine.
5. Lifting capacities assume a machine standing on level, firm and uniform supporting surface. Operator must make allowance for job conditions such as soft or uneven ground, out of level conditions, side loads, sudden stopping of loads, hazardous conditions, inexperienced personnel, etc.
6. The above theoretical ratings are based on calculations derived from standard O.E.M. lift charts based on SAE standard No. J1097. They do not exceed 87% of hydraulic lifting capacity or 75% of tipping capacity. Rated loads marked with an asterisk (\*) are limited by hydraulic lifting capacity.
7. When traveling the machine in either forward or reverse directions to the job site (more than 20 feet), with the boom straight over the front or rear of the machine, the boom should be positioned such that the tip of the tool is approximately 5 feet above the ground, with the mid link fully retracted, and the outer arm and tool perpendicular to the ground. Travel control should be set to low speed and engine RPM at mid range. At the job site, with the boom in the working position (drive sprockets to the rear, boom over the front), the machine may be moved up to 20 feet forward or reverse, travel at low speed setting, engine RPM at mid range, in order to move into the working position, provided ground is firm and level.
8. When swinging the machine 360 degrees, the boom should be in the fully upright position, with the mid link fully retracted, and the outer arm and tool perpendicular to the ground.
9. When shutting down the machine for a period of time, the mid link should be fully retracted, and the boom lowered to rest the outer arm on the ground, with the outer arm and tool positioned parallel to the ground.
10. Do not boom down with tool on the ground and front fully retracted, doing so may cause damage to machine.