

STANLEY®



MSD2250 MOBILE SHEAR

The **MSD2250 Mobile Shear** was designed to address the smaller excavators, targeting carriers in the 55,000 to 100,000 lb weight range. The 2250R is designed to fit smaller, lighter excavators to save fuel and operating costs. This shear is ideal for demolition contractors where transport weight is critical, and for applications needing more piercing and cutting power.

Proven Reversed MSD Cylinder Technology with Speed Valve

- Protects the cylinder rod from being damaged.
- Enables the reduced stick height design increasing visibility and reduces weight.

Heavy Duty Fabricated Tubes

- Reduces stick deflection and "buckling" of the shear stick.

Dual Guide Pucks

- Prevents upper jaw deflection increasing durability and life expectancy of the shear.

Patented Reversible Saber Tip

- Allows for the piercing tip blade to be rotated reducing the cost of ownership.

Shorter Primary Blade

- Increases power at the tip for more piercing ability and at the apex for more cutting power.

Patented Wraparound Blades

- The replaceable blades reduce welding and maintenance time.

Heavy Duty Pivot Components and Wraps

- The heavy duty components contribute to the durability and long life expectancy of the LaBounty Shears.

Heavy Duty Rotation Group

- Allows for placing the smaller shear on a heavier duty carrier without damage to the critical rotation components.
- 360 degree powered rotation.

MSD 2250R

25 m / 75 ft

(Optional Saber Guard wear plating available.)

Additional Features

- Available with rotation (MSD2250R) or without rotation (MSD2250)

Model	(1) Excavator Weight 2nd Member lbs / m tons	(1) Excavator Weight 3rd Member lbs / m tons	(2) MSD Weight lbs / kg	Jaw Opening in / mm	Jaw Depth in / mm	(3) Reach ft / m
MSD2250R	55,000 / 25	110,000 / 50	12,500 / 5,670	30 / 762	30 / 762	11' 9 / 3.6
MSD2250	44,000 / 20	88,000 / 40	10,500 / 4,800	30 / 762	30 / 762	8 / 2.4

(1) Carrier weight recommendation is based on standard published weights and boom and / or arm lengths. All applications must be approved by Stanley LaBounty prior to sale. Boom stick configuration and quick couplers may greatly impact carrier size requirements.

(2) Attachment weights can vary +/- 5%, depending upon mounting bracket configuration.

(3) Reach figures indicate the typical distance from the boom / arm pivot of the base machine to the tip of the shear. Actual reach will vary depending upon the excavator boom / arm combination. Where reach is critical to a particular application, please contact Stanley LaBounty



STANLEY

LaBounty

COMPANY CONFIDENTIAL: INFORMATION HEREIN IS PROPRIETARY INFORMATION OF STANLEY HYDRAULIC TOOLS - LABOUNTY. ANY USE, DISCLOSURE OR DUPLICATION THEREOF IS PROHIBITED UNLESS AUTHORIZED.

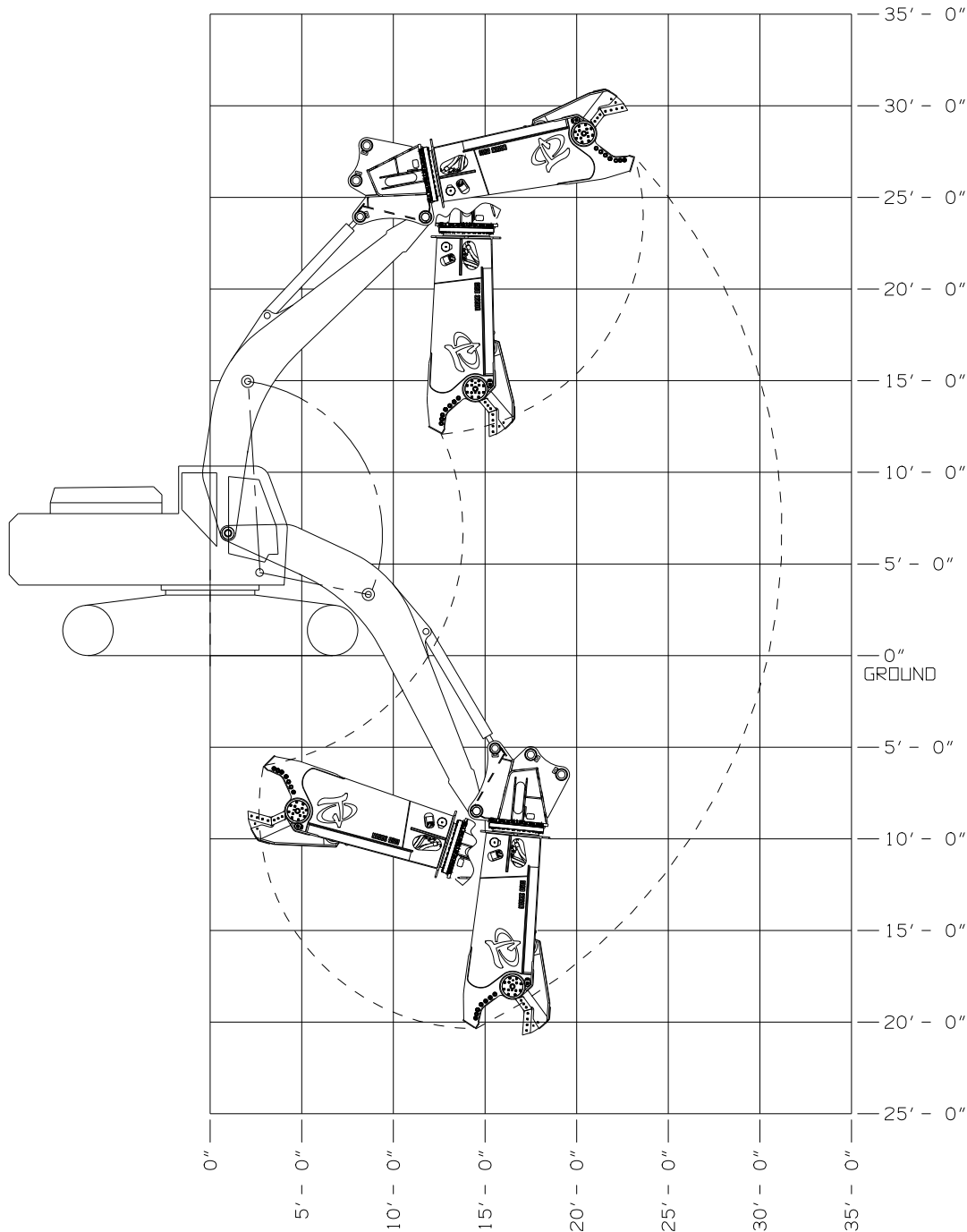

SN622160 ON A KOBELCO SK300LC-10
(MSD 2250R W/ 221140 DUAL MULTI HEAD)