



Safety, Operation & Maintenance Manual

Grapples

STANLEY



CE

INTELLECTUAL PROPERTY – PATENT INFORMATION

This product is covered by one or more of the following patents.

U.S. PATENT NUMBERS:

5,474,242	7,240,869
5,531,007	7,487,930
5,992,023	7,578,461
7,322,273	7,832,130
8,146,256	8,104,384

EPO Patent Numbers

435,702
737,107
1,682,299
1,789,225

PREFACE

This manual contains information for the safe and proper operation and maintenance of the grapple attachment. Read the entire manual before the initial start-up of the attachment. It is important to know the correct operating procedures of the attachment and all safety precautions to prevent the possibility of property damage and personal injury.

The LaBounty attachment has been designed and manufactured with high quality materials and care in workmanship. The instructions in this manual have been prepared to ensure that, when followed properly, the attachment will provide efficient and reliable service. Continuing product development and improvement may have caused changes in the attachment that are not reflected in this manual. If a question arises regarding the operation or maintenance of the attachment, contact a LaBounty dealer for the most current information available.

TABLE OF CONTENTS

Section 1 Introduction

Introduction	1-2
Safety Summary	1-3
Decals.....	1-5

Section 2 About the Attachment

Attachment Description.....	2-2
Attachment Features	2-2
Attachment Terms	2-3
Attachment Glossary	2-4

Section 3 Installation

Grapple Mounting Instructions	3-2
Grapple Removal Instructions.....	3-4
Grapple Storage	3-4

Section 4 Operation

Before You Start	4-2
First Things First	4-2
Safety Devices You'll Need	4-2
General Rules for Safe Operation	4-3
Attachment Controls	4-4
Getting the Feel of the Attachment.....	4-5
The Feathering Technique	4-5
Grapple Operating Tips	4-6
Rear Mounting Pad Position	4-7
Front Mounting Pad Position	4-7

Section 5 Grapple Maintenance

Maintenance Safety Procedures.....	5-2
General Rules for Maintenance	5-2
Periodic Service Schedule.....	5-3
Daily Inspection Checklist.....	5-4
Attachment Lubrication	5-5
Grapple Tine Tip Replacement	5-6
Grouser Bar Replacement Kits	5-7
Wear Plate Service Kit	5-8
Grapple Build Up and Hardsurfacing.....	5-9

SECTION 1 INTRODUCTION

Introduction 1-2
Understand Signal Words 1-2
Safety Summary 1-3
Attachment Decals 1-4

GRAPPLES

INTRODUCTION

Your safety and the safety of others is a direct result of how you operate and maintain your equipment. Read and understand this manual and other safety information provided with the base machine and be sure that you understand all controls and operating instructions before attempting to operate this equipment. Failure to follow the safety precautions can result in personal injury, death or property damage.

Carefully read all safety messages in this manual and on your equipment safety signs. Keep safety signs in good condition; replace missing or damaged safety signs.

Because LaBounty cannot foresee all hazardous circumstances, the precautions listed in this manual and on the equipment are not all-inclusive. If a procedure, method, tool or part is not specifically recommended by LaBounty, determine whether it is safe for you and others, and that the equipment will not be damaged or made unsafe as a result of your decision to implement it.

The basic rules are summarized in this section of the manual. They also appear throughout the manual along with additional specific rules for safety and operation.

UNDERSTAND SIGNAL WORDS

When you see the following symbols and signal words on your equipment or in this manual, be alert to the potential for personal injury or equipment or property damage. Follow recommended precautions and safe operating practices.



Indicates immediate hazards that WILL result in severe personal injury or death.



Indicates hazards or unsafe practices that CAN result in severe personal injury or death.



Indicates hazards or unsafe practices that could result in personal injury.

NOTICE

Indicates notes of importance to a procedure or part.

SAFETY SUMMARY

DANGER

If the attachment is not functioning properly, you must shut the machine down and follow proper lockout, tag, and repair procedures.

DANGER

Ensure that the cab is equipped with the proper safety guards for LaBounty applications. In addition, it is required that the cab be equipped with an approved Falling Object Protection Structure (FOPS) when processing materials. The FOPS must meet the requirements of SAE standard J1356. A transparent shatter-resistant shield covering the front of the cab is also required. Contact your base machine equipment dealer or manufacturer for more information on the availability of FOPS. **Lack of proper FOPS may result in injury or death.**

DANGER

DO NOT process or handle material with the attachment over the operator's cab.

DANGER

DO NOT attempt to shear brittle materials such as axles and railroad rail. Brittle material breaks or shatters instead of shearing. The material being processed could become a projectile and cause injury or death. **DO NOT** process any material in any position that may propel it toward operator, other workers, buildings or equipment.

DANGER

DO NOT close the attachment on a structure and reverse the excavator in an attempt to pull down material.

DANGER

Clear all persons and equipment from the area of operation and machine movement. **NEVER** move loads over people or equipment. When viewing the operation of the attachment, maintain a safe distance of at least 75 feet (22.9 meters).

DANGER

NEVER approach power lines with any part of the machine. Keep clear at a minimum of 15 feet (5 meters).

DANGER

Avoid tipping. The attachment will alter the lift capacities of the base machine. **DO NOT** overload the excavator or serious injury could result. Lift capacities will vary if the base machine is not on level ground. Carry loads in recommended positions for maximum stability. Use the recommended excavator counterweight. Use short slings and lift the load only as high as necessary.

DANGER

DO NOT allow riders on the machine.

DANGER

NEVER remove any pins unless the attachment is on the ground and blocked up or serious injury or death could result. Metal chips or debris may fly when a connecting pin is struck. Use a brass drift when striking pins and always wear protective clothing and proper eye protection. Pins may fly when struck with force to drive them in or out. Keep people clear when removing or installing pins.

DANGER

NEVER operate equipment without the original equipment safety guards in place. If the cab glass is missing or damaged, check with your dealer or manufacturer for proper replacement.

GRAPPLES

SAFETY SUMMARY CONTINUED

⚠ WARNING

Under no circumstances should any modifications be made to LaBounty equipment without factory authorization.

⚠ WARNING

ALWAYS lower the boom to the ground before leaving the cab. If it is necessary to work on an attachment off the ground, securely support the machine and attachment. **DO NOT** support the machine on cinder blocks, hollow tiles, or props that may crumble under continuous load. **DO NOT** rely on a cylinder to hold the attachment in the air. **DO NOT** work under a machine that is supported only by a jack.

⚠ WARNING

DO NOT let hot hydraulic oil get in contact with the skin as it could cause severe burns. Wear adequate protective clothing and safety equipment. **DO NOT** tamper with any hydraulic line or component while it is pressurized. Escaping fluid under pressure can penetrate the skin, causing serious injury. Relieve pressure before unhooking hydraulic or other lines. **See Figure 1-3.** Tighten all connections before applying pressure. Keep hands and body away from pinholes and nozzles which eject fluids under high pressure. Use a piece of cardboard to search for leaks. If **ANY** fluid is injected into the skin, seek immediate medical assistance.

⚠ CAUTION

DO NOT weld on any structural member unless specifically authorized by LaBounty. Any unauthorized welding or welding procedures may result in personal injury.

⚠ CAUTION

ALWAYS wear close-fitting clothing and safety equipment appropriate to the job. Safety equipment should be worn at all times when viewing, operating, or maintaining the attachment to prevent injury. Safety equipment includes eye protection, hard hat, steel toe shoes, gloves, and hearing protection.

⚠ CAUTION

Keep clear of all potential pinch points, including the moving upper jaw, cylinder connections, bucket linkages or other moving parts.

⚠ CAUTION

Before operating the attachment, read and observe all safety instructions in the Operation and Maintenance sections of this manual. If you are unfamiliar with any operation or maintenance procedure, seek instruction before proceeding.

ATTACHMENT DECALS**STANLEY**

**STANLEY LABOUNTY BRAND DECALS
(REPLACEMENT DECALS AVAILABLE UPON REQUEST)
FIGURE 1-1**

SAFETY FIRST

**Read the Safety, Operation and
Maintenance Manual before
operating or servicing the equipment.
Keep the manual with the attachment
so it is available for reference.**

**SAFETY FIRST DECAL PART NUMBER 503590
(INCLUDED WITH MANUALS)
FIGURE 1-2**

GRAPPLES

ATTACHMENT DECALS CONTINUED



GREASE DECAL
PART NUMBER 116338
FIGURE 1-3



SAFE VIEWING DISTANCE DECAL
PART NUMBER 116389
FIGURE 1-4



SAFETY DECAL
PART NUMBER 503647
FIGURE 1-5

STANLEY



1538 Highway 2
Two Harbors, MN 55616
tel: 1-800-522-5059
fax: 218-834-3879
www.stanleyhydraulics.com

Made in the U.S.A. with Global Materials

Attachment Model:

Serial Number:

Year of Manufacture:

Weight:

MODEL/SERIAL NUMBER PLATE
PART NUMBER 511045
FIGURE 1-6

U.S. PATENT NUMBERS

5,474,242
5,531,007
5,992,023
7,322,273
8,146,256

EPO PATENT NUMBERS

435,702
737,107
1,682,299
1,789,225

STANLEY LABOUNTY

1538 Highway 2
Two Harbors, MN 55616

1-800-522-5059

www.stanleyhydraulic.com

FOREIGN PATENTS AND OTHER PATENTS PENDING

STANLEY



116404

PATENT PLATE
PART NUMBER 116404
FIGURE 1-7

SECTION 2 ABOUT THE ATTACHMENT

Model Description2-2
Features.....2-2
Attachment Terms..... 2-3
Attachment Glossary 2-4



GRAPPLES

MODEL DESCRIPTION

Since LaBounty introduced the Contractor's Grapple, many changes have taken place. A wide selection of models and sizes are now available—product refinements have altered the look and performance of LaBounty grapples.

Contractor's grapples are available in two basic models—HDR and TW with sizes ranging for base machines from 25,000 to 240,000 pounds (11,000 to 109,000 kg) and openings from 88 to 150 inches (2.2 to 3.8 meters).

HDR Grapples are designed for versatility. With a two tine upper (movable) jaw and a three tine lower (stationary) jaw, they are unequalled in demolition, scrap recycling, rip-rap, land clearing, log and pipe handling and quarry applications. For scrap handling applications, pointed tine tips are available to provide better penetration into the scrap pile.

TW Grapples feature a four tine upper (movable) jaw and a five tine lower (stationary) jaw. They are designed to handle waste, refuse, and large volumes of loose materials.

FEATURES

- Patented design combines highest payload-to-dead-weight ratio allowing handling and lifting more material.
- Replaceable wear parts for easy maintenance.
- Installs in as little as 15 minutes.
- Factory upgrading and rebuilding services available for extended life
- High-tensile, abrasion-resistant steel construction assures long, uninterrupted service—even in the harshest conditions.

HDR GRAPPLE

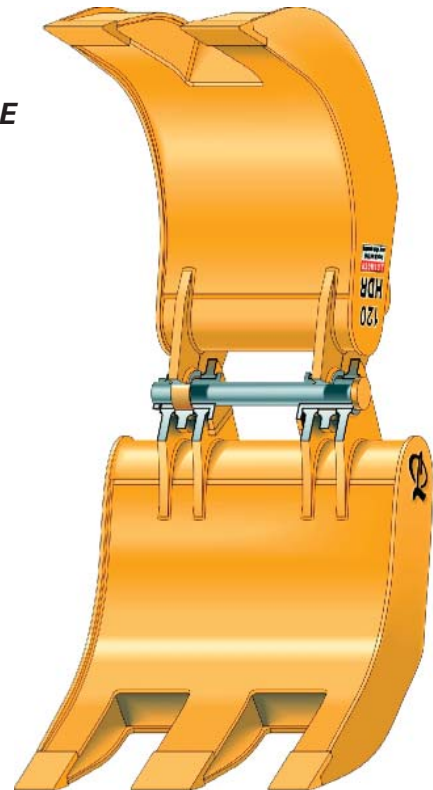

TW GRAPPLE



ATTACHMENT TERMS

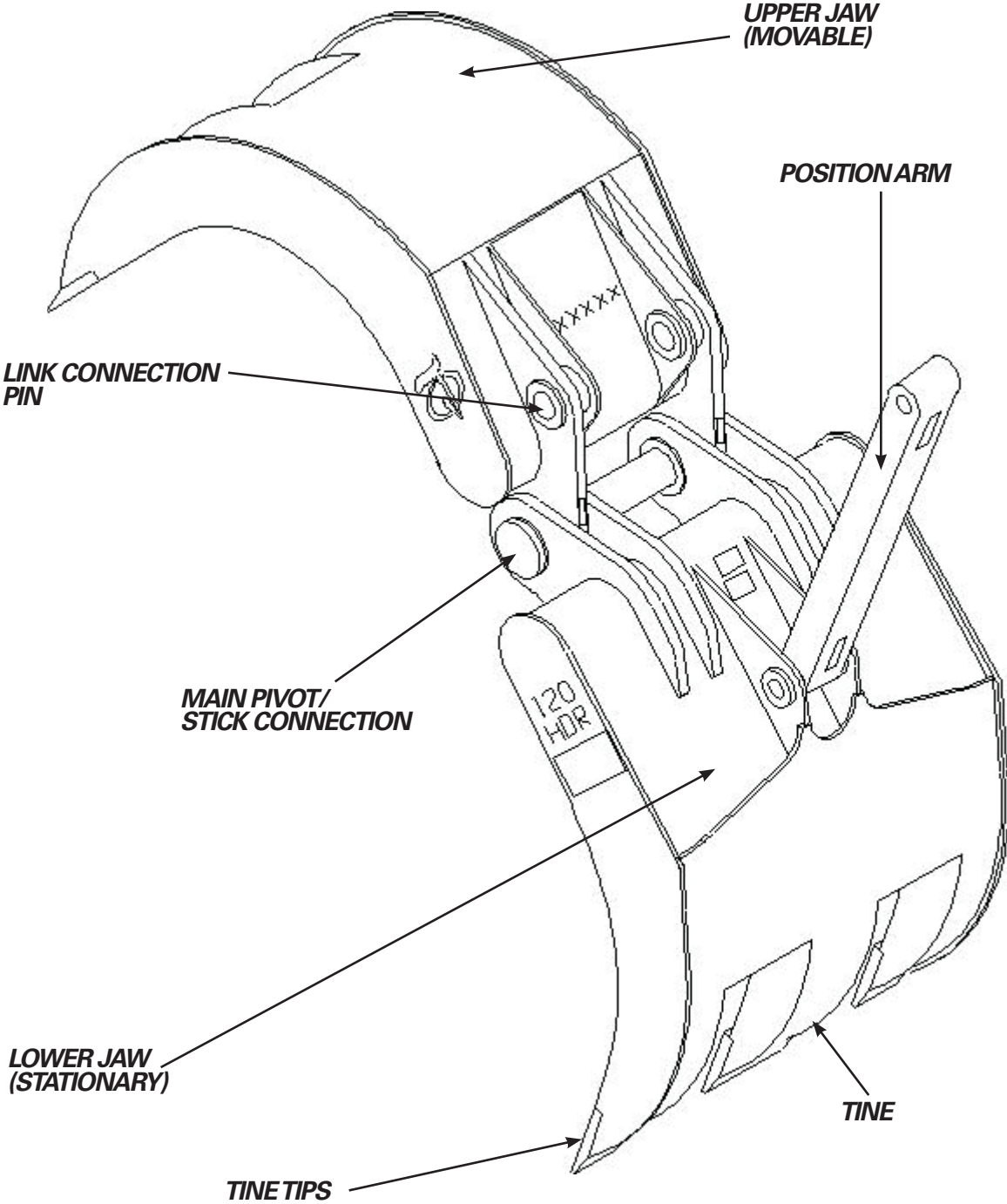

ATTACHMENT GLOSSARY

Build Up	Welding process where worn off parent material is replaced with new metal. A very important maintenance procedure to extend the life of the grapple.
Guide Link	Part of the excavator bucket linkage that pins at one end to the excavator stick and pins at the other end to the bucket cylinder and the power link.
Hardsurface	Welding process for protecting the parent material of the grapple. The hardsurface acts as a wear surface.
Link Pin	The pin that connects the upper jaw of the grapple to the power link of the excavator.
Lower Jaw	The lower half of the grapple that is pinned to the stick at the main pivot and is held stationary by the position arm.
Main Pin	The pin that connects the upper and lower jaws to the excavator stick tip. The main pin is a part of the main pivot.
Main Pivot	Close tolerance area that contains the main pin, spools, and bearings.
Mounting Pad	A bracket welded to the bottom of the excavator stick at a specific location. The position arm pins between the mounting pad and the grapple to hold the lower jaw stationary. The mounting pad properly positions the lower jaw and distributes stresses evenly through the stick during grapple operation.
Position Arm	A structural member pinned between the lower jaw and the mounting pad to support the lower jaw and hold it stationary.
Power Link	Part of the excavator bucket linkage that pins at one end to the upper jaw of the grapple and pins at the other end to the guide link and bucket cylinder.
Spool	A flanged tube that holds the two jaws together and creates a pivot for the upper jaw. There are two spools in the main pivot of a grapple.
Tines	The multiple “fingers” of the grapple used to pick and hold material. The lower jaw has one more tine than the upper jaw.
Tine Tips	The ends of the tines on the grapple. The tips can be built-up and hardsurfaced or replaced when they are worn.
Upper Jaw	The movable, upper half of the grapple that turns on the main pivot and is connected to the power link of the excavator.

SECTION 3 INSTALLATION

Grapple Mounting Instructions3-2
Grapple Removal Instructions..... 3-4
Grapple Storage 3-4



GRAPPLES

GRAPPLE MOUNTING INSTRUCTIONS

It is recommended that the mounting pad not be welded to the excavator stick until the grapple is installed. Mount the grapple as follows:

1. Pin the grapple at the main pivot to the excavator stick as shown in figure 3-1.

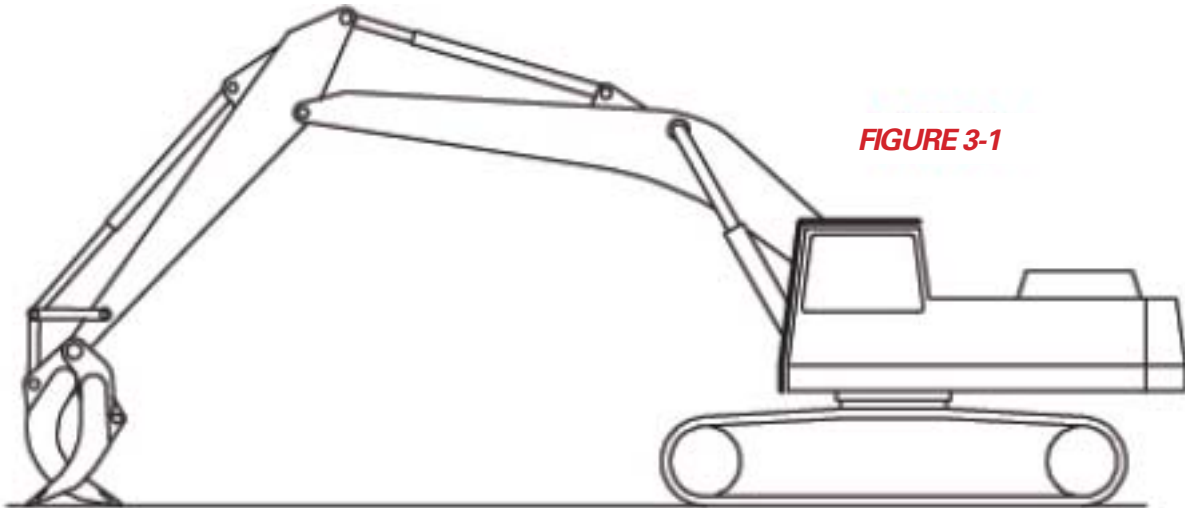

2. Pin the power link to the upper jaw of the grapple.
3. Curl the excavator stick and extend the bucket cylinder to position the lower jaw as shown in figure 3-2.
4. Place the mounting pad on the bottom of the excavator stick. Connect the position arm to mounting bracket at the center hole. Make sure the grease fittings on the position arm will be accessible.
5. Connect the position arm to the lower grapple jaw.
6. Position the mounting pad along the bottom of the stick to obtain the proper distance from the main pin to the center hole of the mounting pad. This distance is shown in the Parts Catalog.

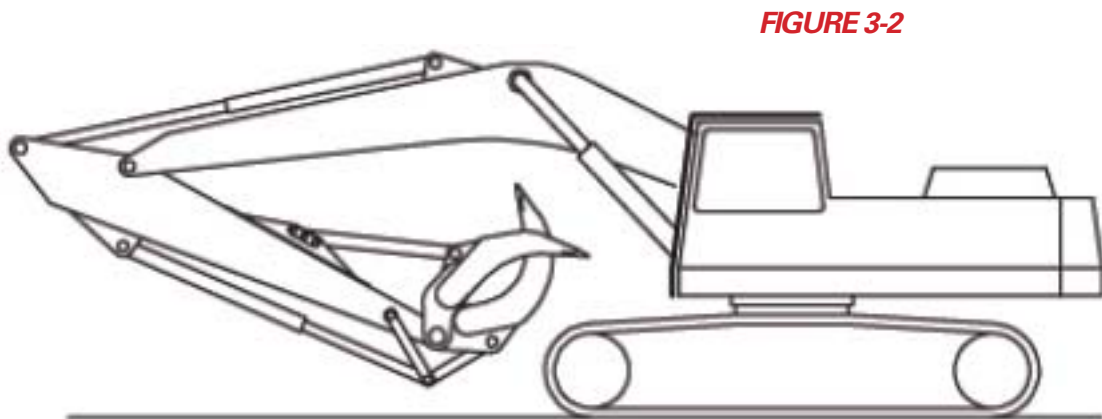

GRAPPLE MOUNTING INSTRUCTIONS continued

7. Weld the bracket in position using E7018 low hydrogen welding rod. Make 1/2" (12.7 mm) fillet welds 3" (76 mm) long, 6" (150 mm) on center (see figure 3-3). Run out welds 1 1/2" (40 mm) on ends and grind to taper in both the side view as shown in side weld detail (figure 3-4) and in top view weld detail (figure 3-5).

NOTICE

Under no circumstances should the mounting pad be welded around the ends—this could lead to cracking on the bottom of the stick (or arm) weldment of the excavator (see figure 3-3).

NOTICE

If the grapple is equipped with a custom mounting pad, refer to the Parts Catalog for mounting instructions. If further information is needed, please contact your LaBounty dealer or the LaBounty Customer Service Department.

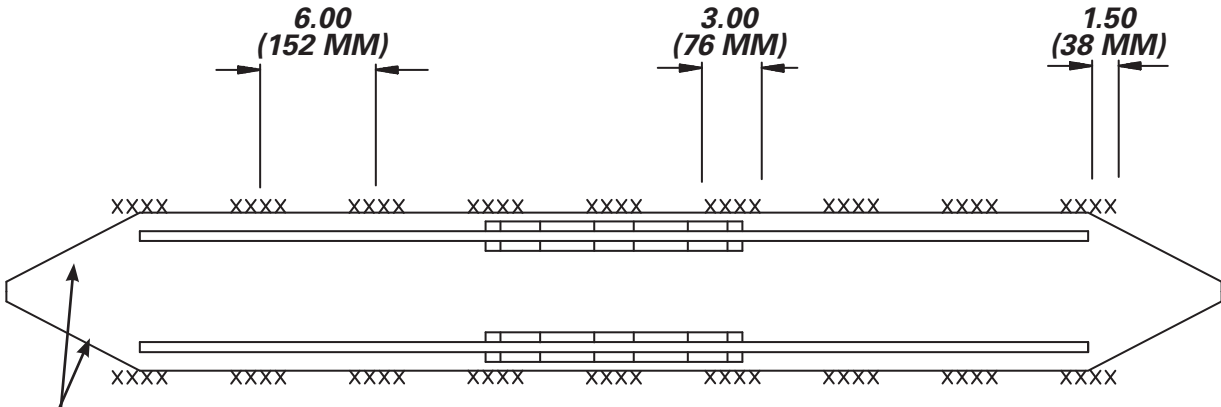

DO NOT WELD AROUND ENDS

FIGURE 3-3

RUN OUT WELDS, GRIND WELD TO TAPER (SEE WELD DETAILS BELOW)



SIDE VIEW WELD DETAIL

FIGURE 3-4



TOP VIEW WELD DETAIL

FIGURE 3-5

GRAPPLES

GRAPPLE REMOVAL INSTRUCTIONS

1. Fully close the grapple and place it on a solid level surface in the position shown in figure 3-6.
2. Support the position arm while removing the pin from the mounting pad then lower the position arm to the ground.
3. Remove the pin from linkage connection.
4. Remove the pin from the main pivot. Carefully raise the excavator stick away from the grapple.

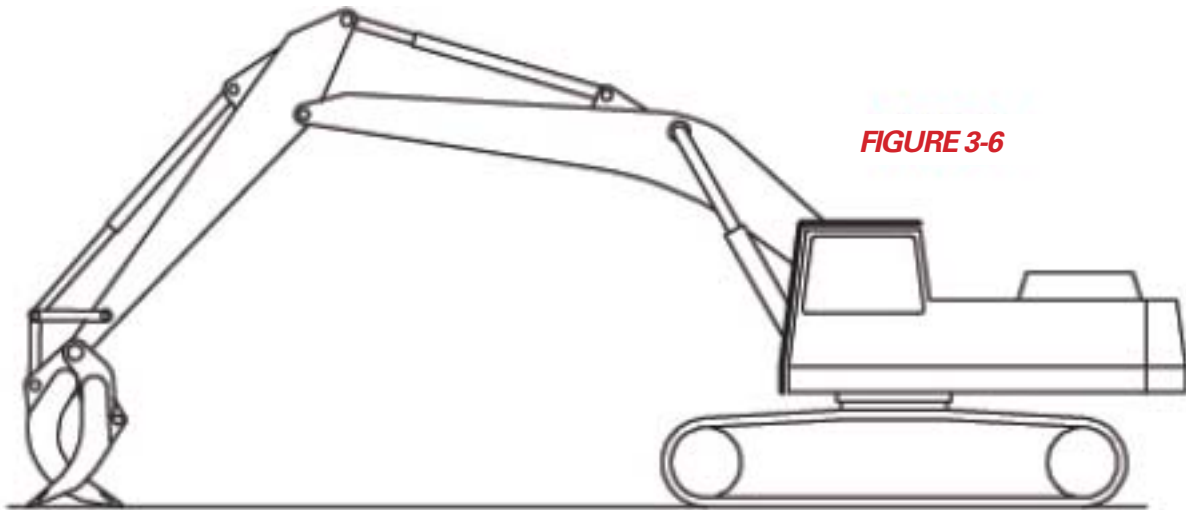

GRAPPLE STORAGE INSTRUCTIONS

1. Place the attachment on a solid level surface.
2. Apply a coating of grease to the bores, pins, and any other exposed, unpainted surfaces.
3. Replace all pins in their bores to prevent misplacing them.
4. Grease at all locations (refer to the lubrication instructions in the maintenance section of this manual).

SECTION 4 OPERATION

Before You Start	4-2
First Things First	4-2
Safety Devices You'll Need	4-2
General Rules for Safe Operation	4-3
Attachment Controls	4-4
Getting the Feel of the Attachment.....	4-5
The Feathering Technique	4-5
Grapple Operating Tips	4-6
Rear Mounting Pad Positions.....	4-7
Front Mounting Pad Position	4-7



GRAPPLES

BEFORE YOU START

KNOW YOUR SAFETY PROGRAM

1. Read and understand the safety section of this manual and the base machine manual.
2. Know the employer's safety rules for your job. Consult your foreman for specific instructions and safety equipment required.
3. Learn the traffic rules at the work site.
4. Know the hand signals used on the job and who is responsible for signaling. Take signals from only ONE person.



KNOW YOUR EQUIPMENT

- Learn the location and function of all controls. Test all controls to ensure proper operation. If any malfunctions are found, shut the machine down and report the malfunction for repair.
- Be familiar with the safety devices on the machine, indicators, warning devices and caution instructions. They will alert you to conditions that may make it hazardous to continue operating.
- Wear proper protective clothing including hard hat, safety shoes, ear protectors, reflective clothing, safety goggles and work gloves. Loose clothing can get caught in machinery and cause injury. Wrist watches, rings and other accessories can be dangerous, as well.
- Know the clearances in the work area.

FIRST THINGS FIRST

1. Ensure all safe viewing distance decals are installed and legible; contact LaBounty for replacements as required.
2. Have a DAILY Safety Dialog with all those with whom you work. Inform them of any out-of-the-ordinary work that may be planned for the day. Remind them of the safe working distance.
3. Clear the area; inspect. **ALWAYS** look out for others. In any work area, people constitute a serious safety hazard. Before operating, walk completely around the machine to be sure there are no workers next to, under or on it. Warn nearby workers that you are starting up; **DO NOT** start up until they are out of danger.
4. Each day before starting, visually inspect the machine by walking around it entirely; check the location of cables, gas lines, and water mains before any operations. Make sure work site footing has sufficient strength to firmly support the machine. When working close to an excavation, position machine with the propel motors at the rear.
5. Once started, keep bystanders clear, especially before moving the boom, swinging the upper structure, or traveling. **ALWAYS** be alert for bystanders in or near the operating area.

SAFETY DEVICES YOU'LL NEED

Seat belts
Canopies
Falling Objects Protective Structures (FOPS)
Shields and guards
Safety decals
Visual or audible warning devices
Flags and flares
Barricades
Signs and other markings
Warning lights

GENERAL RULES FOR SAFE OPERATION

1. Read the Operator's Manual for the excavator that the grapple is on. Know the control levers and their functions. Also note **ALL** safety devices on the machine and ensure that they are working properly.
2. **KNOW** the capacity of the excavator and its attachments. **DO NOT** overload the machine or serious injury could result.
3. It is required that a Falling Objects Protection Structure be installed surrounding the excavator cab for all material handling applications.
4. **DO NOT** use attachment for anything except what it is intended for or warranty will be voided.
5. **DO NOT** operate a poorly maintained or damaged grapple. Inspect and lubricate the grapple daily.
6. **ALWAYS** maintain a safe operating distance between any material suspended and held by the attachment and the cab of the machine.
7. **NEVER** leave a load suspended in the air, pass it over people, occupied vehicles or buildings or serious injury could result.
8. **ALWAYS** keep a watchful eye on exposed parts, such as the position arm, so as to not damage them when working in confined spaces.
9. **ALWAYS** maintain at least 15 feet (5 meters) between the attachment and any nearby power lines or serious injury could occur.
10. When leaving the machine for any reason, **ALWAYS** lower the grapple to the ground.
11. **DO NOT** close the attachment on a structure and reverse the excavator in an attempt to pull down material.
12. **AVOID** collision of the boom or attachment, especially when working with limited visibility or inside buildings. Know the height and reach of the processor during operation, travel and swinging upper structure.

13. **AVOID** contacting machine with the attachment or any material held by it.

14. Use machine swing for positioning only. **DO NOT** use the attachment as a jack hammer or wrecking ball.

15. **AVOID** contact between boom arm or attachment and overhead obstacles when you operate, move or haul the machine.

16. The attachment is not a dozer. **DO NOT** position the lower (stationary) jaw of the grapple on the ground and travel forward.

WARNING

Determine the control for each movement of the processor before attempting to operate. Practice the machine movements as described in "Getting the Feel of the Attachment" on page 3-6.

GRAPPLES

ATTACHMENT CONTROLS

The Stanley LaBounty grapple replaces the bucket of an excavator and operates with the same controls—no additional hydraulics are required. The bucket dump control opens the processor and the bucket curl control closes the attachment (see figures 4-1 and 4-2, below).

BUCKET CURL OUT = GRAPPLE OPEN

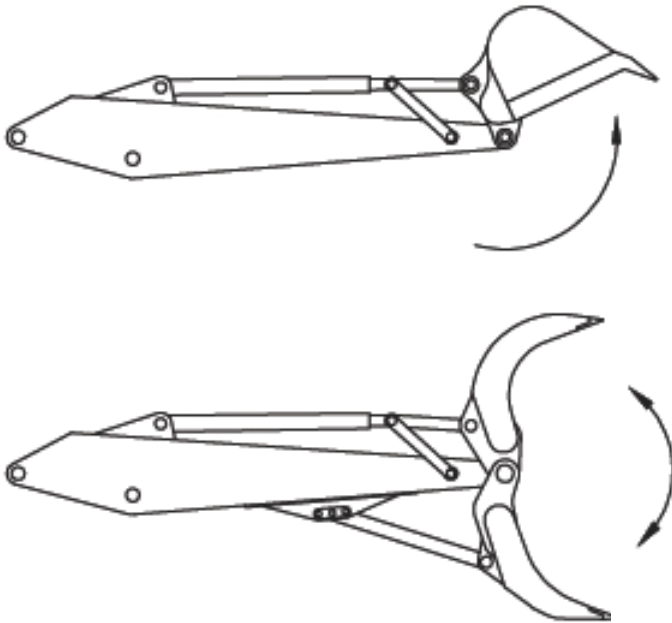

FIGURE 4-1

BUCKET CURL IN = GRAPPLE CLOSED

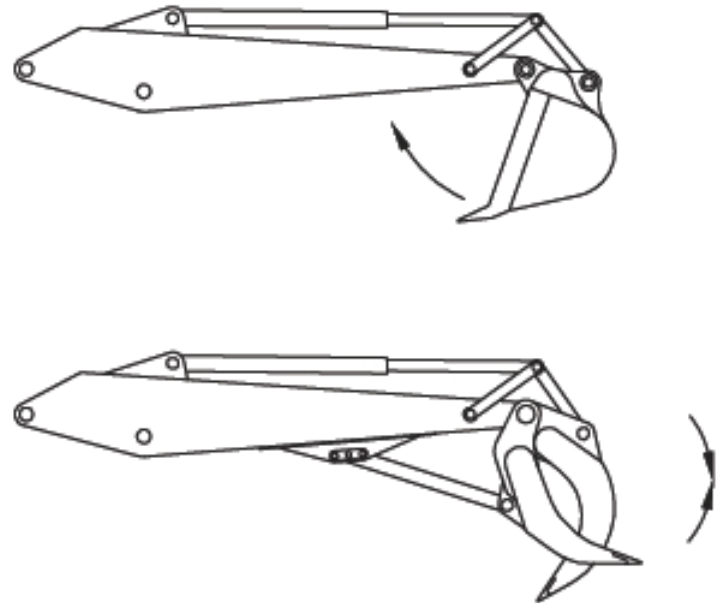

FIGURE 4-2

GETTING THE FEEL OF THE ATTACHMENT

Every part of any machine has a slightly different “operating feel”—an individual machine response to the movement of the controls. Before starting the first job with a new machine, it is suggested that the operator find an open spot on firm, level ground that is free of obstructions such as trees, buildings and other equipment—and safely away from other people. Move the machine to this area and spend some time just getting to know the operating feel of the machine and the grapple in order to become familiar with the control levers and grapple before beginning work.

The machine is exceedingly powerful. Do not operate carelessly; there is potential for personal injury and equipment damage. Be concerned about safety when preparing to operate the new machine. Ensure safe operation by inspecting the machine as stated in “Getting Started Safely,” which includes a commonsense visual check of the machine at the beginning of every operation.

Follow a preventive maintenance program; such a procedure will reduce the possibility of costly downtime. Read the “Getting Started Safely” section of this manual and understand it.

THE FEATHERING TECHNIQUE

The fluid nature of hydraulic power requires a special operating approach to the attachment that can be described as a smooth, even technique. The control levers should be moved in a gradual, deliberate way rather than with jerky, abrupt movements; jerky operation can cause damage and early wear to various parts of the machine, and can also overheat the hydraulic system.

As each control lever is moved forward or backward from the neutral position, the oil flows to the cylinder or motor controlling a function. The component (boom, grapple, etc.) starts to move. The component moves faster as the control lever is moved further forward or backward. Holding the lever in the forward or backward position will hold that movement at a given rate of speed. To slow the movement down, gradually move the lever toward the neutral position. Movement is stopped at the neutral position. The position is maintained until the control lever is moved again. See figure 3-6 on page 7.

“Feathering” the controls is a technique that will increase loading output and make operating the machine easier. To “feather” when starting any motion of the machine, move the control slightly from neutral until it starts to move, then smoothly move the control to increase motion to desired speed. Do the same when stopping a motion.

GRAPPLES

OPERATING TIPS

The mounting pad of a LaBounty Contractor's Grapple has three pin positions. By using the different positions, the angle of the lower (stationary) grapple jaw can be adjusted (see figure 4-3). For each type of job, the lower jaw may be positioned to make it more productive or easier to use.

Use the following guidelines to find the best position for your current job. Some experimentation may be necessary to learn the advantages of each position.

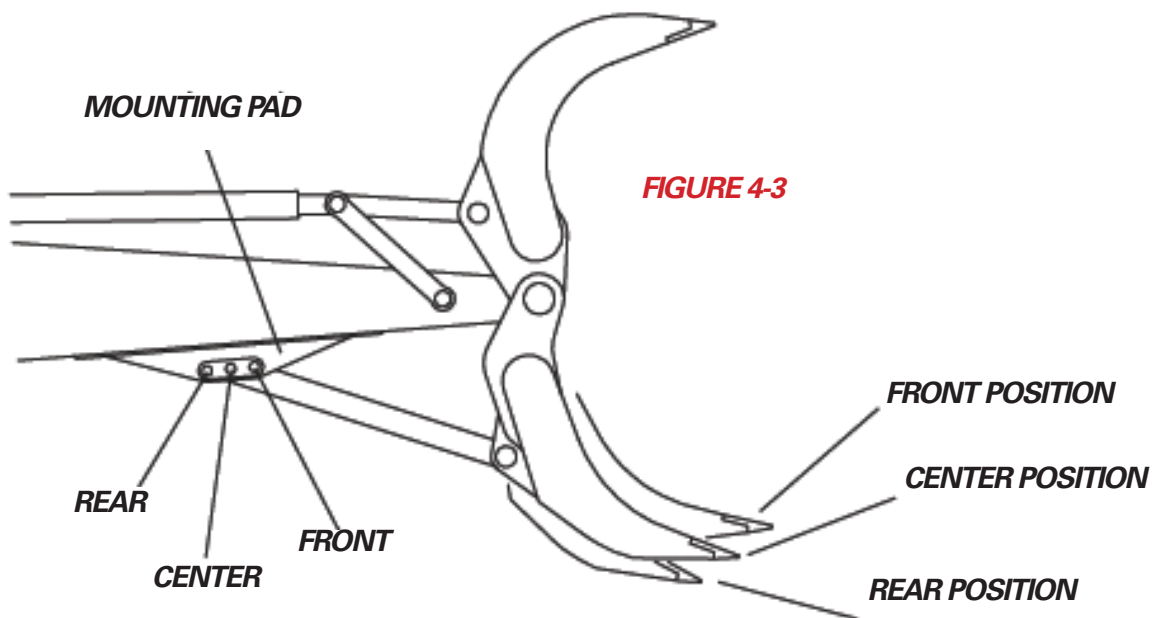

CENTER MOUNTING PAD POSITION

Use the center position for general use. This will position the lower jaw to provide the best performance for a great range of uses. Some operators leave the grapple in this position for all applications.

REAR MOUNTING PAD POSITION

Using the rear position increases the amount of grapple opening. This mounting pad position can make it easier to handle large amounts of light materials and can also make it easier to empty the grapple—as when loading a dump truck (see figure 4-4).

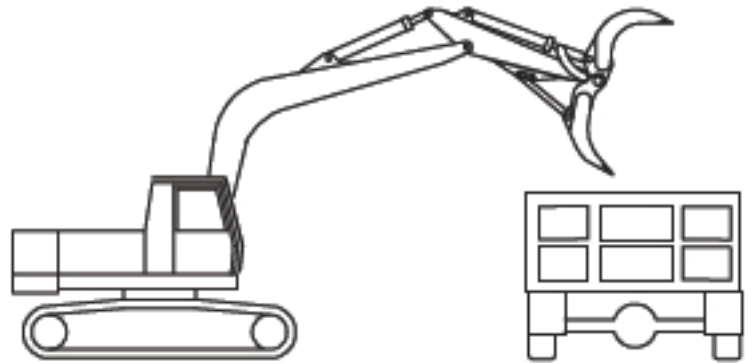

FIGURE 4-4

FRONT MOUNTING PAD POSITION

NOTICE

DO NOT use tractive effort in this configuration; it will cause damage to the position arm mounting pad, and/or excavator stick.



FIGURE 4-5

Using the front position decreases the amount of grapple opening. This position sometimes works well when working at ground level because the lower jaw can be kept parallel to the ground (see figure 4-5). In this position, use the boom and stick in a raking motion to load the grapple. This mounting position can also be useful when placing objects, such as rip-rap.

SECTION 5 GRAPPLE MAINTENANCE

Maintenance Safety Procedures.....	5-2
General Rules for Maintenance	5-2
Periodic Service Schedule.....	5-3
Daily Inspection Checklist.....	5-4
Attachment Lubrication	5-5
Grapple Tine Tip Replacement	5-6
Grouser Bar Replacement Kits	5-7
Wear Plate Service Kit	5-8
Grapple Build Up and Hardsurfacing.....	5-9



MAINTENANCE SAFETY PROCEDURES

Before attempting any maintenance procedure, read the entire Safety Manual carefully. If any question arises regarding a safety or maintenance procedure, contact your LaBounty dealer.

- Inspect the attachment daily. **DO NOT** operate a poorly maintained or damaged attachment or major structural damage could result.
- If it is necessary to work on an attachment off the ground, securely support the machine and attachment. **DO NOT** support the machine on cinder blocks, hollow tiles, or props that may crumble under continuous load. **DO NOT** rely on the cylinder to hold the attachment in the air. If a control is moved or hydraulic pressure is otherwise released, the attachment will drop. **DO NOT** work under a machine that is supported solely by a jack.
- **DO NOT** attempt to alter or change the physical, mechanical or hydraulic operation of the attachment during the warranty period without first consulting Stanley LaBounty as this could invalidate the Manufacturer's Warranty.
- **NEVER** operate the machine if an unsafe condition exists. Attach a **"DO NOT OPERATE"** tag to the machine.
- If more than one person is working on a machine, each must be familiar with the controls and aware of what the others are doing. Before working on a machine, **BE SURE TO TAG THE CONTROLS SO NO ONE ELSE WILL START IT.**
- **ALWAYS** use two people when making checks with the engine running – the operator at the controls must be able to see the person doing the checking.
- Keep hands away from moving parts. **NEVER** lubricate or work on a machine while it is moving.
- **ALWAYS** wear proper safety equipment when maintaining the attachment including safety glasses with side shields, hard hat, steel toe shoes, gloves, and hearing protection.
- **DO NOT ATTEMPT REPAIRS YOU DO NOT UNDERSTAND. ASK FOR HELP BEFORE STARTING IF YOU ARE UNSURE.**

GENERAL RULES FOR MAINTENANCE

1. Read the maintenance procedures in this manual. Be sure all maintenance personnel read and understand all maintenance procedures before working on the equipment.
2. Before servicing or shutting down the machine, lower the attachment to the ground and stop the engine.
3. Use factory approved parts. Use of parts that are not factory approved may cause damage or unnecessary downtime.
4. **DO NOT** substitute with non-LaBounty parts unless you know they are the same in all characteristics or the factory warranty may be voided.
5. Lubricate daily—follow the lubrication schedule outlined in this manual.
6. Inspect the tine tips and wear areas daily.
7. Use the included inspection checklist while doing attachment inspection to make sure all maintenance is complete.
8. **DO NOT** preheat cutting tine tips in excess of 400°F (204°C) during build-up and hardsurfacing.
9. When hardsurfacing, **DO NOT** exceed two passes of hardsurface rod; use Amalloy 814H or equivalent.
10. Other than the build-up and hardsurfacing procedures in this manual, do not weld on the attachment without first consulting the factory.
11. Refer to the parts catalog for your specific attachment part numbers. Be sure to know the attachment serial number before ordering.
12. Please call your authorized LaBounty dealer if any problem occurs that is not outlined in this manual.

PERIODIC SERVICE SCHEDULE

SERVICE THE ATTACHMENT AT SPECIFIED INTERVALS

Inspect, lubricate, make service checks and adjustments according to the Daily Inspection Checklist reproduced from this manual.

A program of regular service should be established, using the machine hour meter to determine when the attachment should be serviced. Use the intervals on the Service Schedule when operating in normal conditions. Service the attachment at shorter intervals when operating in extreme environmental or abrasive conditions.

USE CORRECT LUBRICANTS

Refer to the Lubrication Instructions in this manual when performing maintenance on the attachment.

WARNING

During maintenance of the attachment, it is imperative that the excavator is turned OFF to prevent injury.

DAILY SERVICE REQUIRED

Grease Fittings. Lubricate according to Lubrication Section of this manual. Replace broken or damaged grease fittings immediately.

Connecting Pins and Pin Retaining Bolts. Inspect for tightness or damage or wear on main pivot pin and linkage pin. Check pinheads and pinstops.

Tine Tips. Inspect for wear to determine if build-up and hardsurfacing is required. If the tips are excessively worn, they may need to be replaced. Refer to the maintenance instructions in this section for proper procedures.

GRAPPLES

DAILY CHECKLIST

Attachment Model _____ Excavator Hour Meter _____

Attachment Serial Number _____ Date _____

- _____ **1.** Inspect attachment for any damage. Inspect tine tips and if necessary, maintain as outlined in this manual.
- _____ **2.** Inspect connecting pins and pin retaining bolts
- _____ **a.** Main pivot pin
 - _____ **b.** Linkage connection pin
 - _____ **c.** Position arm pin (both ends)
- _____ **3.** Grease all points until excess appears. Use Premium Grease No 2EP or equivalent
- _____ **a.** Main pivot
 - _____ **b.** Linkage connection
 - _____ **c.** Position arm (both ends)
 - _____ **d.** End of main pivot pin (if required)
 - _____ **e.** End of linkage connection pin (if required)
 - _____ **f.** Check excavator for grease fittings at attachment connecting pins

Inspected by: _____

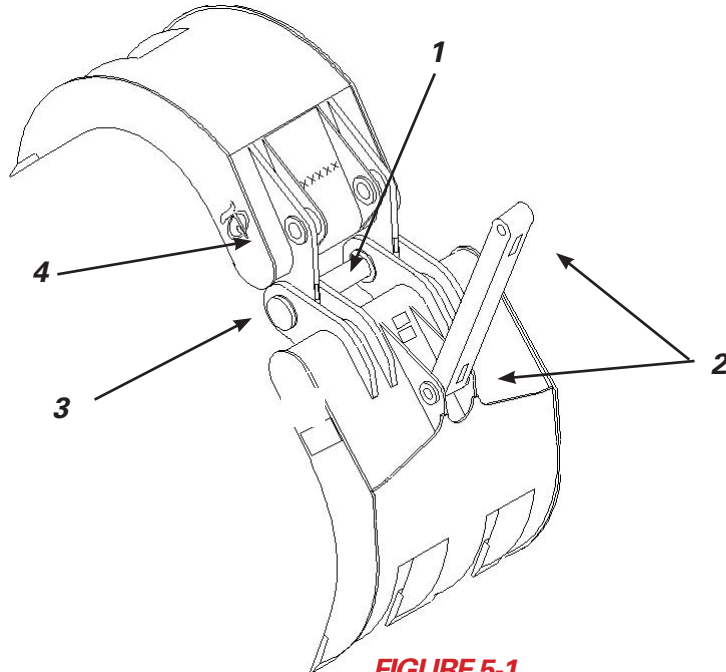
ATTACHMENT LUBRICATION**FIGURE 5-1**

1. Refer to figure 5-1. Grease all points every 8 hours of grapple operation. Use Amoco Rykon Grease No 2EP or equivalent.
2. Grease fitting locations are indicated on the illustrations and by yellow GREASE decals on the attachment.
3. Fill with grease until excess grease appears.

LOCATION ON ATTACHMENT

1. Main pivot connection—movable jaw
2. Position arm
3. Main pivot attachment pin (if needed)
4. Linkage connection pin (if needed)

QUANTITY

2
2

GRAPPLES

GRAPPLE TINE TIP REPLACEMENT

LaBounty Grapples are originally equipped with very hard wear resistant tine tips that will wear after extended use. When there is approximately one inch (25.4 mm) left of each tine tip (see figure 5-2) it is recommended they be replaced to prevent damage to the grapple frame. Do not allow the tip to wear down to the tine base material.

Tine tip replacement kits are available from LaBounty. Consult the parts catalog for your grapple and contact your LaBounty dealer to order. Use the following procedure to replace a tine tip.

1. Place the grapple in a secure position with the jaws open and blocked up about 18" high, or preferred working height.
2. Clean all dirt and grease from the tip.
3. Use a straight edge to cut the worn-out edge square and in line with the other tips, approximately 3/4" (19 mm) from the back edge of the tip profile (see figure 5-3).
4. Preheat the area to be welded.
5. Position the new tip and tack weld in place. Use a straight edge to ensure alignment (see figure 5-3).
6. Use a low hydrogen E7018 weld rod or equivalent to weld the tips in place. Weld the bevels of the replacement tine tips and grind smooth (see figure 5-3).

NOTICE

Before installing new tips, grind the area to be welded so it is flat and smooth. Remove any carbon residue from when the tip was removed.

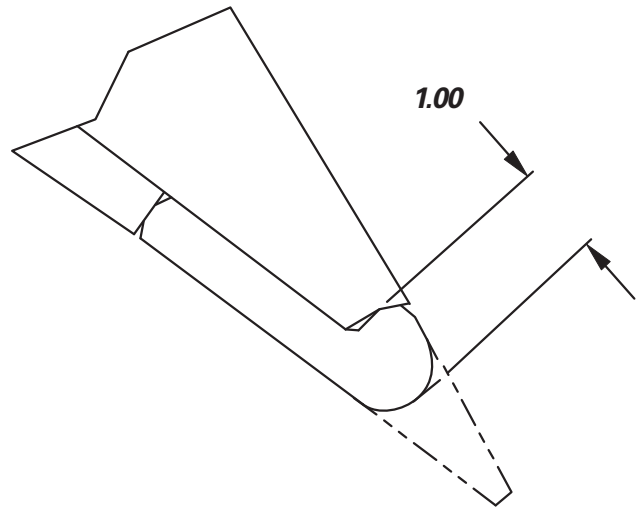

FIGURE 5-2

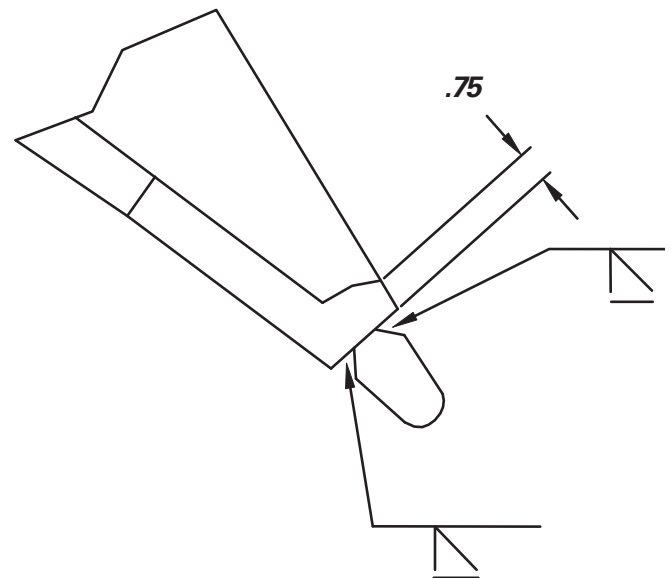

FIGURE 5-3

GROUSER BAR REPLACEMENT KITS

Use the tables below to determine what part number is needed. Contact your dealer or Stanley LaBounty directly to order, or for more information on availability.

HDR 50/70/100/170/200

LENGTH (IN)	PART NUMBER
6.00	129513
6.25	129955
6.50	128309
7.00	129461
7.13	176613
7.63	177124
8.00	132015
8.63	177385
8.75	160351
9.00	129512
9.50	177565
9.75	128400
10.00	129460
10.25	176614
10.63	177123
12.00	132016
12.83	177384
70.75	131949

HDR 30/40 AND OLDER 100/110

LENGTH (IN)	PART NUMBER
4.00	129969
5.00	308117
5.25	129973
5.50	129968
5.88	129972
6.00	129966
6.38	176498
7.50	129967
8.88	129970
9.00	129971/176497
9.50	128398
47.47	130115

GRAPPLES

WEAR PLATE SERVICE KIT

Wear kits are available for grapples that may work in extremely abrasive applications such as rock, concrete, or brick handling and some scrap applications. Wear kits consist of additional plate steel welded to the front and back of both grapple halves. Contact your dealer or Stanley LaBounty directly to order, or for more information on availability.



FIGURE 5-5
WEAR PLATE SERVICE KIT

GRAPPLE BUILD UP AND HARDSURFACING

When excessive wear is found on the grapple tines and tips, build up and hardsurfacing are required. For extremely severe applications, a special wear kit available from LaBounty may provide additional plating of those areas normally associated with wear in such situations.

The areas that will likely need build up and hardsurfacing are the inner and outer faces of the grapple tines. The sides of the frames adjacent to these areas may also need this maintenance. The procedure for build up and hardsurfacing a Contractor's Grapple is as follows:

1. Clean the areas to be built-up and hardsurfaced to remove any grease, paints, or other foreign materials that may be harmful to the weld.
2. Preheat the area to 200-300°F (100-150°C) and maintain this temperature throughout the build up and hardsurfacing procedure.
3. If build up is to be applied, use a low hydrogen E7018 welding rod or equivalent and weld in single passes following the grain of the steel (see figure 5-6). Tip build up can be applied cross-grain (see figure 5-7). Peen each pass.
4. To hardsurface, use an electrode with an abrasive rating of 60-70, hardness of 50-58 Rc and an impact rating of 4.
5. Hardsurfacing should be applied in no more than two layers using a crosshatch pattern at a 45° angle to the vertical. The space between the passes should be from 1" to 2" (25 to 51mm). Peen after each pass.
6. Cover the welded area with a heat blanket. Let it cool slowly before putting the grapple back into service.

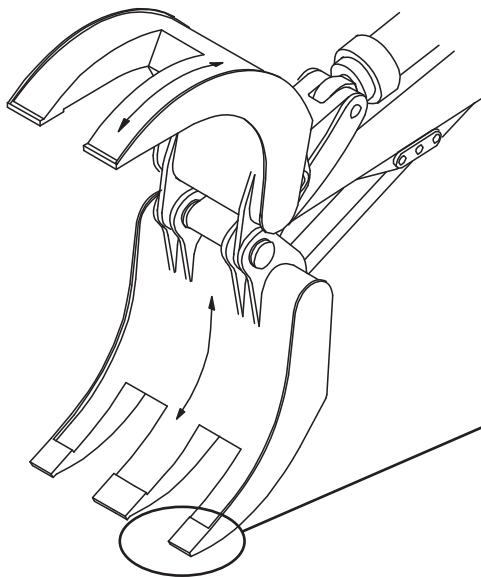

FIGURE 5-6
ARROWS SHOW GRAIN DIRECTION

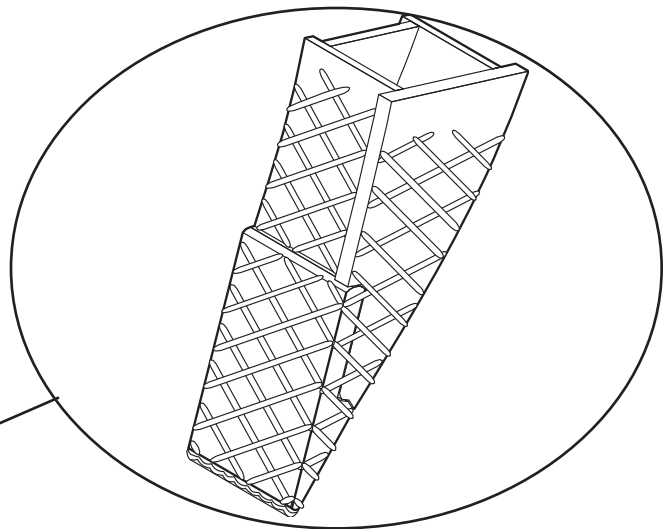

FIGURE 5-7
HARDSURFACING PATTERN
1" TO 2" (25 TO 51 MM) SPACING

LIMITED WARRANTY

New Attachment

Stanley LaBounty warrants its manufactured products against deficiency in material or workmanship for a period of 12 months from the date of first use, rental or sale, or 1500 hours of operation, whichever occurs first.

LIMITATIONS

- Remanufactured or used product or service repair are not warranted under this Limited Warranty.
- Product that is damaged by alteration, improper maintenance, unauthorized service, abuse, misuse, or contamination by the base machine is not warranted.
- This Limited Warranty is the exclusive warranty. Stanley LaBounty makes no representations, expressed or implied, of merchantability or fitness for a particular purpose.
- Agents of Stanley LaBounty have no authority to make representations beyond those contained herein.

EXCLUSIVE REMEDY

The exclusive remedy for a product Stanley LaBounty determines deficient in material or workmanship is repair or replacement at Stanley LaBounty's option. The following procedure governs a repair or replacement warranty claim:

1. All warranty claims require a claim number provided by Stanley LaBounty Service Department.
2. A factory-issued Return Material Authorization tag (RMA) must accompany returned product.
3. Returned product found deficient by Stanley LaBounty will be replaced or repaired without charge FOB Distributor/Customer or will be credited to account balance.
4. Authorized repair can occur at the Stanley LaBounty factory or authorized Stanley LaBounty Dealer. Labor for warranty repair will be paid under a formula determined by Stanley LaBounty.

Stanley LaBounty is not liable for incidental or consequential costs or losses incurred by the product, purchaser or user.

LIMITED WARRANTY

To validate the Limited Warranty, a completed warranty certificate and delivery inspection report must be returned to Stanley LaBounty. Prohibited operation and/or unauthorized adjustment or assembly will void this Limited Warranty. See the Operation, Maintenance and Safety Manual.

CONTACT INFORMATION

Contact your Stanley LaBounty Dealer or Stanley LaBounty regarding warranty questions. All requests for information, service or spare parts should include model and serial numbers. For the nearest Stanley LaBounty dealer contact:

Stanley LaBounty
1538 Highway 2
Two Harbors, MN 55616-8015 USA
Phone: (218) 834-2123 or (800) 522-5059
FAX: (218) 834-3879
E-mail: labounty@stanleyworks.com
Website: www.stanleyhydraulic.com



T109605 The STANLEY and LABOUNTY names and logos are registered trademarks of Stanley Solutions