

2 1/2 YARD CLAMSHELL

Rotation	Continuous	
Capacity	2.50 yd ³	1.91 m ³
Cylinder Bore	4"	101.6mm
Bolt on Edge	Serrated or Regular	
Cylinder Max. Pressure	5000 psi	345 bar
Weight	5900 lb	2676 kg

200 SERIES DANGLING ROTATOR

Rotation	Unlimited	
Lifting capacity	112000 lb	50802 kN
Max pressure	1450 psi	10.0 MPa
Torque at max. pressure	21900 lb-in	29692.5 Nm
Rotator flow	10 gpm	38 L/min
Rotation speed	15 rpm	
Weight	850 lb	386 kg

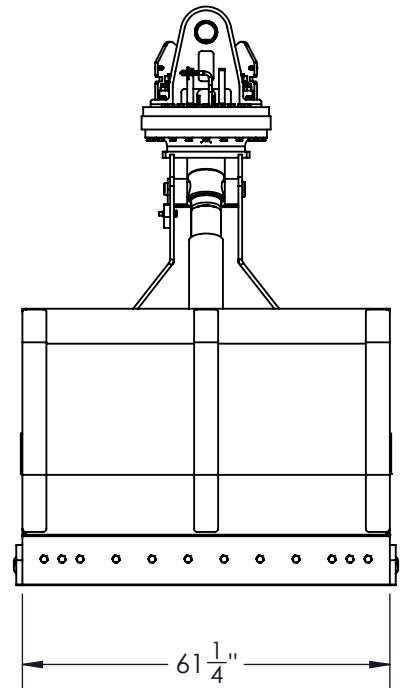
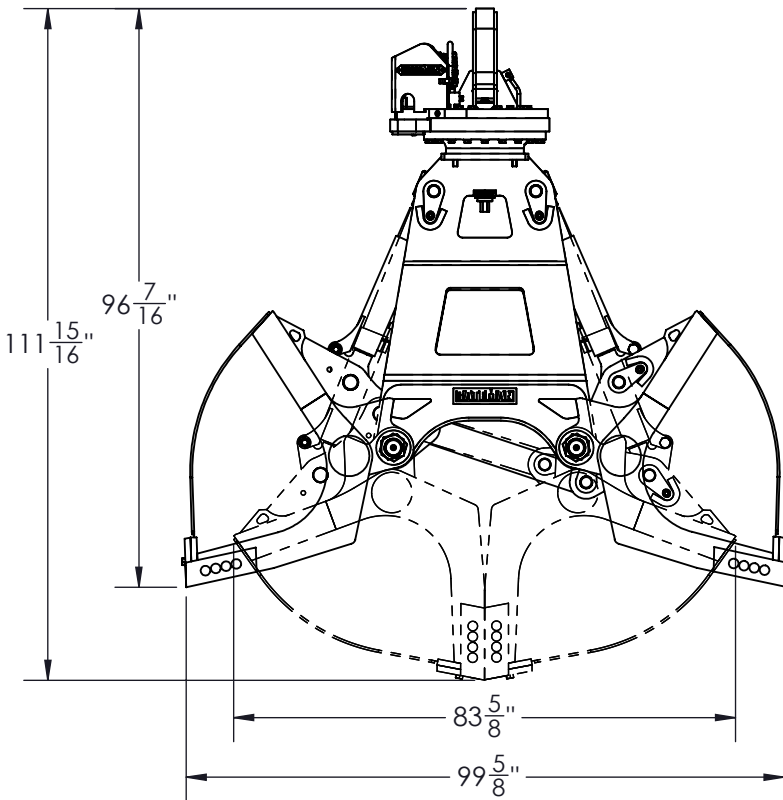

BATEMAN MANUFACTURING
 5 WINSTAR ROAD RR#1
 SHANTY BAY, ONTARIO,
 L0L 2L0, CANADA

WWW.BATEMANMANUFACTURING.COM
MAIL@BATEMANMANUFACTURING.COM
 PHONE: 705 784-5020
 FAX: 705 487-5290

