

MMG55DF4 | 2.9 L | 55kVA

MOBILE DIESEL GENERATOR SET

EPA Emissions Certification: Final Tier 4

GENERAC® | MOBILE

Standby Power Rating

48 kW, 60 kVA, 60 Hz

Prime Power Rating

44 kW, 55 kVA, 60 Hz



Image used for illustration purposes only



*Assembled in the USA using domestic and foreign parts

Codes and Standards

Generac Mobile products are designed to the following standards:



CSA



NATM



TIER 4 FINAL EMISSIONS



ISO 8528-5

Power When and Where You Need It

Generac Mobile diesel generators are designed and engineered to power a variety of projects, in the most extreme environments. Gensets are configured to meet customer needs, including choice of containment, cold weather packages, trailer options, and more.

Generac Mobile diesel generators are manufactured to deliver reliable power, when and where you need it.

STANDARD FEATURES

ENGINE SYSTEM

- John Deere® 3029HFG03
- 3 cylinder
- Turbocharged
- 177 in³ (2.9 L) displacement
- EPA Final Tier 4 approved
- Power @ 1,800 rpm – hp (kW):
 - Prime: 67 (50)
 - Standby: 74 (55)
- Iso mounted engine supports
- Paper element air filter with safety cartridge
- Electronic isochronous governing
- Fixed speed fan drive
- Spin-on cartridge oil filter
- Containment

FUEL SYSTEM

- Fuel tank capacity – gal (L):
 - Total: 100 (379)
 - Usable: 90 (341)
- Maximum run time @ 100% load: 23 hr

COOLING SYSTEM

- Capable of operating at 120 °F (49 °C) ambient
- Oil filter: Spin-on cartridge, full flow
- Air filter: Disposable – paper element
- Radiator and oil drains plumbed to exterior

SYSTEM OUTPUTS

- Voltage selection switch: 3-position, lockable

GENERATOR

- 60 Hz engine/generator
- Marathon Electric® 286PSL1701
 - Brushless
 - 4-pole
 - Class H insulation

ENCLOSURE

- Aluminum, sound attenuated
 - Paint: UV and fade resistant, high temperature cured, white polyester powder
 - Insulated and baffled
- Fully lockable – including doors and fuel fill
- Exterior emergency stop switch
- Central lifting point
- Multi-lingual operating and safety decals
- Document holder with owner’s manual – includes AC and DC wiring diagrams

TRAILER

- DOT approved tail, side, brake, and directional lights; recessed rear lights
- Surge brakes
- Transportation tie downs
- Safety chains with spring loaded safety hooks
- 2 in (50.8 mm) ball hitch
- Single axle – 6,000 lb (2,722 kg)
- 2,000 lb (907 kg) tongue jack with footplate
- Tires: 15 in (38.1 cm), 6-ply, tubeless

WARRANTY

- 2 year limited or 2,000 hours
 - Unlimited hours covered in first year

CONTROL SYSTEM

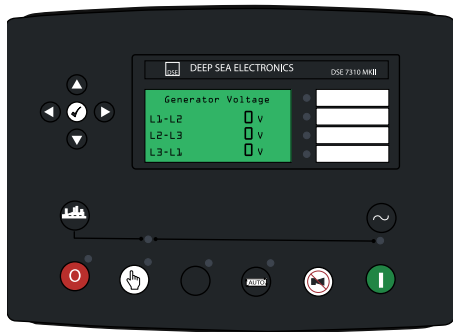

010643

Deep Sea® CONTROLLER AND DISPLAY

- Model DSE7310 MKII
- 4-line back-lit LCD text display
- -40 to 158 °F (-40 to 70 °C) operating temperature range
- Multiple language options
- Configurable timers & alarms
- Configurable start/stop timers
- Configurable maintenance alarms
- Heated display

PUSH BUTTONS FOR EASY OPERATION

- Manual or Auto start
- Engine start
- Engine stop/reset
- User-friendly setup and button layout
- Five key menu navigation
- Hours counter
- Multiple parameters are monitored & displayed simultaneously for full visibility
- View controller parameters (configuration, firmware version, connections)

LCD ALARM INDICATION

- Generator diagnostic display
 - System kVA output display
 - Line output and frequency display
- Alarm types: Warning, Shutdown, Electrical Trip, Engine
- Alarm list – warnings/shutdowns; 250 event history log – date/time stamp
 - Fuel level: warning – 15%; shutdown – 5%
 - Overspeed protection: shutdown – 110%
 - Engine diagnostic warnings communicated through J1939 CANbus
 - Battery voltage: over – 15 VDC; under – 11 VDC
 - Generator over voltage: warning – 110%; electrical trip – 115%

- Generator under voltage: warning – 90%; shutdown – 85%
- Generator over frequency: warning – 105%; electrical trip – 110%
- Generator under frequency: warning – 95%; electrical trip – 90%
- Auto-schedule
- Status

ELECTRICAL CONTROLS

- Remote start/stop contacts in receptacle box
- Lockable control box door with diagnostics window
- Lockable lug box with safety switch
 - Trips main breaker when door is opened
 - Disables voltage regulator
- Output ground connection lug inside lug box
- 225 A main breaker with shunt trip
- Convenience receptacles with individual breakers (restricted use in high wye mode)
 - Two 120 V, 20 A, GFCI, duplex outlets (NEMA 5-20R type)
 - Three 125/250 V, 50 A, 3-pole, 4-wire, twist-lock outlets (non-NEMA 6369)
- Voltage adjustment ±10%
- One 12 V, 720 CCA, wet cell battery

MMG55DF4 | 2.9 L | 55kVA

MOBILE DIESEL GENERATOR SET

EPA Emissions Certification: Final Tier 4

GENERAC® | **MOBILE**

OPTIONS*

ENGINE SYSTEM

- Block heater
- 60/40 coolant
- Heated fuel filter
- Electronic positive air shutdown

FUEL SYSTEM

- Extended run tank: 160 gal (606 L), with containment
- Auxiliary 3-way fuel valve
- Leak detection

TRAILER

- Tandem axle
- Electric brakes
- Toolbox: Black polymer or aluminum, 49×15×18.5 in (125×38×47 cm)
- Rear stabilizer jacks
- 2 in (50.8 mm) BULLDOG® hitch
- 2-5/16 in (58.7 mm) BULLDOG hitch
- 3 in (76.2 mm) lunette ring
- Spare tire

CABINET

- Fire extinguisher

CONTROL SYSTEM

- 4-position phase switch
- PMG
- Buck transformer
- Cam locks: Single set, female
- 10 A battery charger
- AGM sealed battery (Optima) 720 CCA

RATING DEFINITIONS

Standby: Applicable to varying emergency load for the duration of a utility power outage.

Prime: Applicable to supplying power to a varying load in lieu of utility for an unlimited amount of running time.

*Consult factory for availability



MMG55DF4 | 2.9 L | 55 kVA

MOBILE DIESEL GENERATOR SET

EPA Emissions Certification: Final Tier 4



APPLICATION AND ENGINEERING DATA

ENGINE SPECIFICATIONS

General

Make (Model)	John Deere (3029HFG03)
EPA Emissions Compliance	Final Tier 4
After Treatment System	DOC and DPF
Cylinders – Qty	3
Type	In-Line
Displacement – in ³ (L)	177 (2.9)
Bore – in (cm)	4.2 (10.7)
Stroke – in (cm)	4.3 (11.0)
Compression Ratio	16.9:1
Intake Air Method	Turbo/Air-To-Air

Engine Governing

Governor	Electronic
Frequency Regulation (Steady State)	±2%

Lubrication System

Oil Pump Type	Gear Driven
Oil Filter Type	Spin-On Cartridge, Full Flow
Crankcase Capacity – qt (L)	11 (10.4)

Cooling System

Cooling System Type	Radiator and CAC
Water Pump Type	Belt Driven
Fan Type	Pusher
Fan Speed – rpm	2,268
Fan Diameter – in (cm)	11.42 (29.0)
Cooling System Capacity – qt (L)	18 (17)

Fuel System

Fuel Type	Ultra Low Sulfur Diesel
Fuel Specifications	EN 590 / ASTM D975
Fuel Filtering – μ	5
Fuel Inject Pump – Make (Model)	Denso (HP3)
Fuel Pump Type	Engine Gear Driven
Injector Type	Electronic
Engine Type	Direct Injection High Pressure Common Rail
Fuel Supply Line Diameter – in (mm)	0.375 (9.5)
Fuel Return Line Diameter – in (mm)	0.375 (9.5)

Engine Electrical System

System Voltage – VDC	12
Battery Charger Alternator – VDC (A)	12 (65)
Battery Size – CCA	720
Battery Voltage (Battery Qty)	12 (1)
Ground Polarity	Negative (-)

ALTERNATOR SPECIFICATIONS

Make (Model)	Marathon Electric (286PSL1701)
Poles – Qty	4
Field Type	Rotating
Insulation Class – Rotor	H
Insulation Class – Stator	H
Total Harmonic Distortion	<5%
Telephone Interference Factor	<50

Standard Excitation	Brushless
Bearings	Single Bearing
Coupling	Direct Flexible Disc
Prototype Short Circuit Test	Yes
Voltage Regulator Type	AVR
Quantity of Sensed Phases	1
Regulation Accuracy (Steady State)	±0.5%

MMG55DF4 | 2.9 L | 55kVA

MOBILE DIESEL GENERATOR SET

EPA Emissions Certification: Final Tier 4



OPERATING DATA

POWER RATINGS

	Standby: kW/kVA (A)	Prime: kW/kVA (A)
1-phase, 120/240 VAC @ 1.0 pf*	46/46 (192)	42/42 (175)
3-phase, 120/208 VAC @ 0.8 pf	48/60 (167)	44/55 (153)
3-phase, 120/240 VAC @ 0.8 pf**	48/60 (144)	45/55 (132)
3-phase, 277/480 VAC @ 0.8 pf	48/60 (72)	45/55 (66)

*Alternator limited.

**Power ratings achieved through use of optional 4-position phase switch.

FUEL CONSUMPTION RATES

Load	Fuel: gph (Lph)	
	Standby	Prime
50%	NA	2.3 (8.7)
75%	NA	3.2 (12.1)
100%	NA	3.9 (14.8)

Deration – Operational characteristics consider maximum ambient conditions. Derate factors may apply under atypical site conditions.

Please contact a Generac Mobile Authorized Service Dealer for additional details. All performance ratings in accordance with ISO3046, BS5514, ISO8528, ISO8665, ISO3046, SAE J1228, SAE J1995, and DIN6271 standards.

MMG55DF4 | 2.9 L | 55 kVA

MOBILE DIESEL GENERATOR SET

EPA Emissions Certification: Final Tier 4



DIMENSIONS AND WEIGHTS*

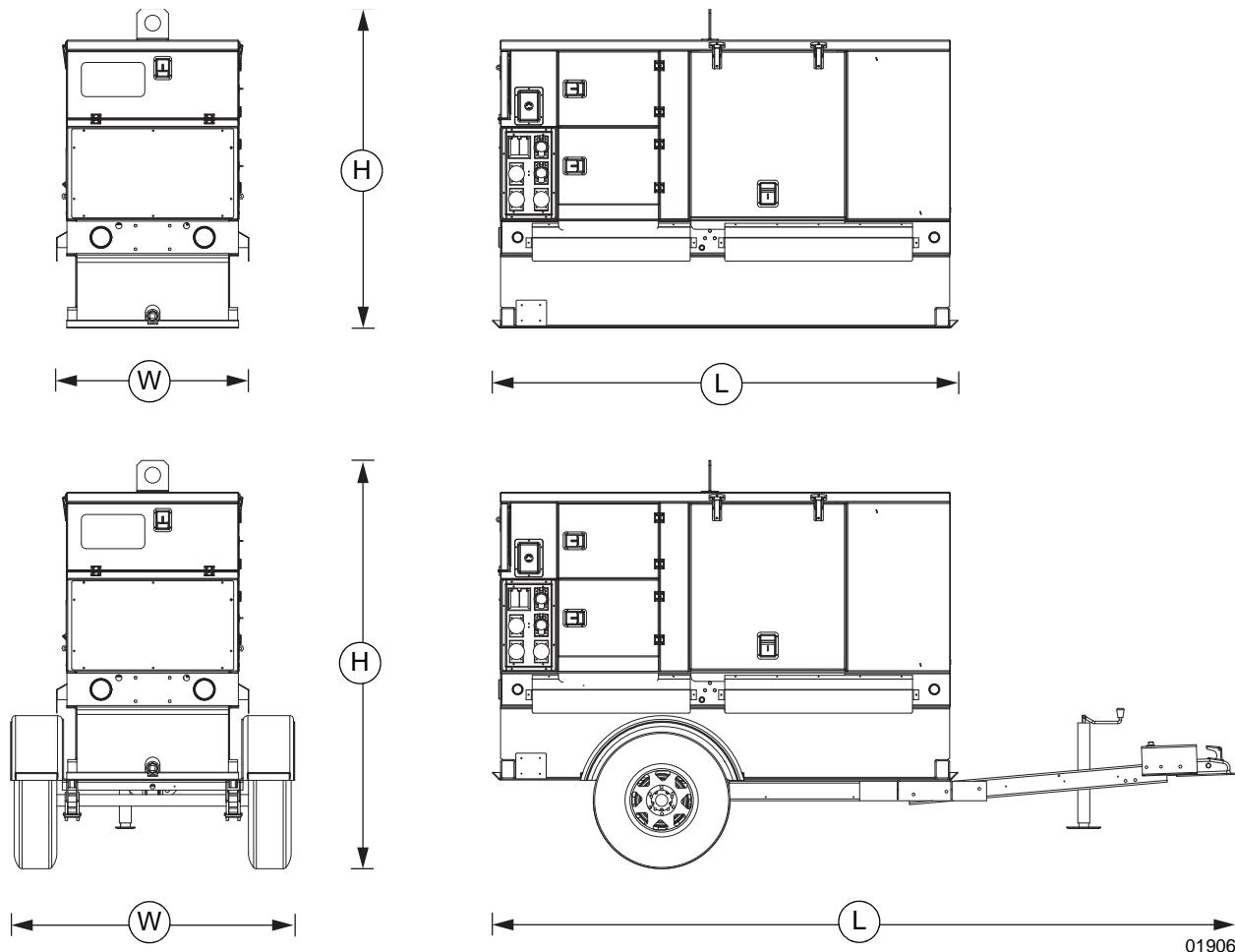

01906

	Run Time: hr	Usable Fuel Capacity: gal (L)	Dimensions – L×W×H: in (m)	Weight: lb (kg)
Skid	23	90 (341)	95 (2.41) × 39 (.99) × 65 (1.65)	Dry: 3,305 (1,499)
				Operating: 4,040 (1,833)
Trailer	23	90 (341)	152 (3.81) × 58 (1.45) × 83 (2.11)	Dry: 3,905 (1,771)
				Operating: 4,640 (2,105)

SOUND RATING

- 68 dB(A) @ 23 ft (7 m) @ prime power

* All measurements are approximate and for estimation purposes only.

YOUR FACTORY RECOGNIZED GENERAC MOBILE DEALER

Specification characteristics may change without notice. Dimensions and weights are for preliminary purposes only. Please contact a Generac Mobile Products Authorized Service Dealer for detailed installation drawings.