

**131X**  
SERIES



# INTRODUCING THE NEXT IN THE X SERIES

Our vision from the start was to design and engineer our most advanced tracked excavator range ever.

The new JCB 13 ton machine sits perfectly alongside its highly acclaimed 20 ton big brother.

Our engineering teams have once again obsessed over every minute detail of this new world-class excavator and used the same quality materials and proven components.

The result is another machine in the X SERIES to be taken seriously. Another machine to be trusted.

*Anthony Bamford.*

LORD BAMFORD, CHAIRMAN, JCB





# EXTREME STRENGTH

## Tested to extremes.

**1** JCB X-Series excavators are tested on a whole-machine shaker rig to replicate 15,000 hours of tracking and vibration.

The latest JCB dig end has been proven over countless hours on machines operating around the globe in every imaginable application.

Exhaustive testing on purpose-built electronics and electric rigs prove the reliability of connections, layout and software.

**2** Windows and doors are tested with 30,000 open and close operations to prove component quality.

**3** Hot and cold climate testing (131°F to -22°F) is performed in controlled conditions and real-world applications.

## Exceptional build quality

**4** Proven undercarriage with fully-welded X frame construction for long-term durability.

Components by the industry's leading suppliers and most trusted brands.

**5** For enhanced strength, X-Series excavators feature rigid upper frames, flat revolver side skirts and double skinned doors with plated hinges.

Robust fold back mechanism for cab mirror.

Finite element analysis ensures longer life for key components.

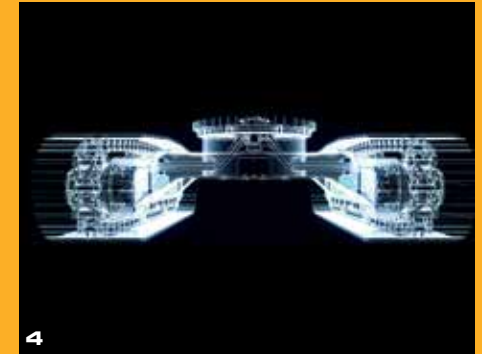

**Best operator environment.**

**1** Spacious JCB CommandPlus cab with high-quality, injection molded interior. Industry-leading Grammer seat with 145-degree recline and wide, adjustable arm rests.

T-bars with optimized ergonomics are standard; new track pedal design with non-slip coatings.

**2** For optimum control and reduced fatigue, the joystick and switch controls are mounted to pods that are suspended from the seat and move with the operator.

**3** The powerful new HVAC system features 11 targeted vents for optimum performance in hot and cold environments.

A cool/heat box is standard.

**4** An industry-standard isolator lever prevents accidental activation when exiting the cab.

**5** A spacious luggage tray behind the operator's seat with includes three independent 12V power supplies. Another handy storage space can be found at the back of the cab in the roof liner, with a hanger for the operator's hard hat.

**6** Bluetooth radio is fully integrated into the control screen.



1



2



3



4



5



6







## Effortless working.

- 1** Proven Japanese hydraulics deliver precise and efficient control.
- 2** The operator can choose Auto-Stop and Auto-Idle, depending on preference.
- 3** Customizable proportional controls allow the operator to set speed and attachment control preferences.

A dozer option adds extra versatility. A power boost button increases pressure by 9 percent for up to 9 seconds, to provide extra tearout in tough conditions.

- 4** Tracking control adjustments can be made on the joystick. A convenient button configures a range of functions such as radio mute, camera cycle or front screen wash.
- 5** Slew drive provides high torque on acceleration and braking for greater controllability and refinement.







**X**  
SERIES



# EXTREMELY EASY

## Easier to use.

**1** A start-stop button eliminates the need to turn the key to restart the machine. The start sequence enables operation within two seconds.

Numerous language options are available for the navigation menu, to suit most operators.

**2** Pipework shut-off taps feature SAE fittings for quick connection of attachments.

**3** An advanced tool select system improves attachment handling by monitoring pressure and flow.

**4** The 131X features an easy quick hitch with an override for removing large breakers or fork attachments.

**5** Available options include a fitting to accommodate a GPS system, including 2D and 3D Topcon, Trimble and Leica models.

**6** The cab has mounting points for protective guards and features flat front glass for easy replacement when needed.







JCB

JCB

131X LC

JCB

X  
SERIES



# EXPERIENCE GREATER PERFORMANCE

## Best-in-class productivity.

**1** Large diameter hydraulic pipes and hoses increase productivity and efficiency. An innovative hydraulic regeneration system recycles oil across the cylinders for faster cycle times and reduced fuel consumption.

**2** The auto-stop and auto-idle feature on the JCB EcoMAX Tier 4 Final engine enables fuel saving of up to 5%.

**3** JCB offers a full range of auxiliary pipework options, including hammer, merged pump flow, auxiliary and low flow.

**4** Effective machine cooling in temperatures up to 131°F heat, even with the with air conditioning running, is achieved with a 15 percent larger hydraulic cooler for optimum airflow.

**5** The Tier 4 Final-compliant 74hp JCB EcoMAX engine requires no DEF, for fewer hassles and lower running costs.





# EXTRAORDINARY ATTENTION TO DETAIL

## World-class finish.

**1** All components are painted in-house at JCB's state-of-the-art paint facility. JCB's paint process includes quality checks for adhesion and coverage.

All JCB machines undergo 1,232 validation checks, including vibration, pressure and temperature tests, that replicate real application conditions.

**2** Fewer vented and open areas means stronger bodywork and reduced painted edges.

**3** Doors are zinc-coated for rust protection on all wear faces and are bolted directly to the frame.

A new bolt and washer design protects paint from damage. All fasteners have a Geomet zinc finish for improved corrosion resistance.

**4** New recessed counterweight design protects the rear end from impact damage.

## World-class assembly.

**5** Robot welding of the dig end and undercarriage ensures consistent quality and accuracy.

**6** The slew ring mounting face is machined after manufacturing and welding to ensure a flat surface that reduces slewing noise.

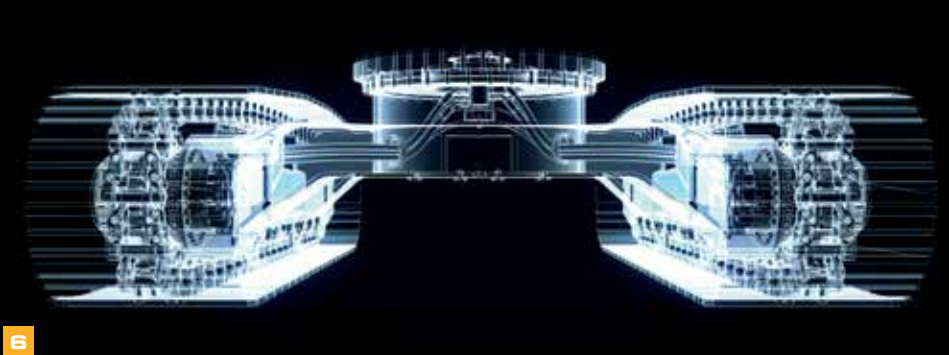
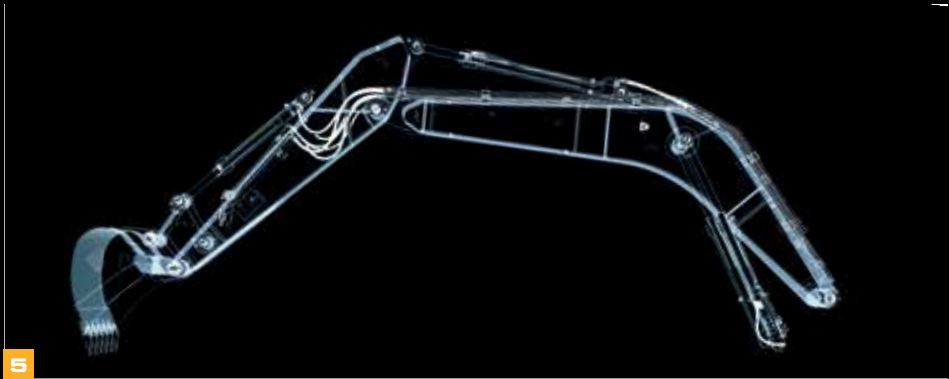





**X**  
SERIES



# EXTENDED SERVICE INTERVALS

## Simple servicing.

- 1** Grouped greasing points so regular maintenance is easier and faster.
  - 2** An optional refuelling pump is available, with or without an in-line fuel filter.
  - 3** Ground-level access to the hour meter, HVAC filter, cab air filter and single fuse box.
- Optional LED convenience lighting for the service bay and upper structure.
- 4** Bolt-on handrails and mirrors can be easily replaced if needed.
  - 5** 1,000-hour engine air filter life thanks to JCB's standard-fit system with Powercore Nanofilter technology.
  - 6** Large, single-face cooling pack for more efficient cooling and easy access.



# EXCEEDINGLY SAFE

Operators, service engineers and site workers benefit from JCB's unique approach to safety, with features designed into the machine to make work safer for everyone.

## Safer working.

- 1 The I31X boasts anti-slip surfaces and comfortable grab handles. To make servicing more comfortable, kneeling areas are free of tread plate.
- 2 Flat, safe operator access to the top of the machine with built in kick strips around the edges.
- 3 Optional twin or 360-degree cameras aid safe operation.
- 4 The optional dipper limiter can be configured to avoid a cab strike.





# EXTRA SUPPORT

JCB LIVELINK IS AN INNOVATIVE SOFTWARE SYSTEM TO MONITOR AND MANAGE YOUR MACHINES REMOTELY – ONLINE, BY EMAIL OR BY MOBILE PHONE.

## Machine efficiency.

By providing information such as idle time monitoring and fuel consumption, JCB LiveLink saves you money and improves productivity.

## Machine benefits.

Accurate hours monitoring and service alerts improve maintenance planning. Critical machine alerts and maintenance history records are also available.

## Security benefits.

Livelink's real-time geofencing alerts advise when a machine is moved out of a predetermined zone and real-time curfew alerts inform of unauthorized usage. Further benefits include real-time location information, advanced ECU matching (pairs Livelink with the immobiliser or ECU), and remote PIN code management.

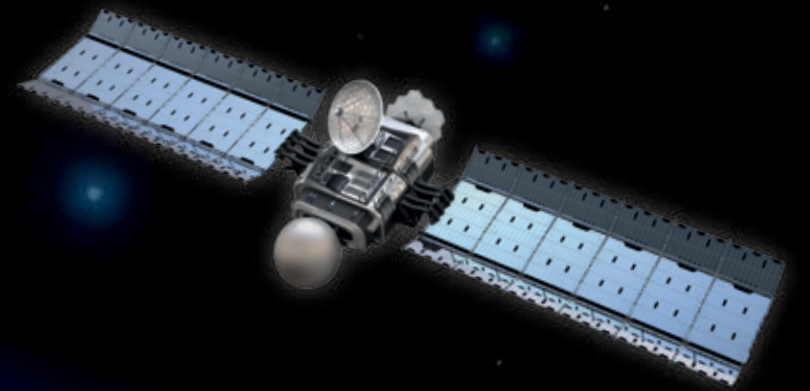

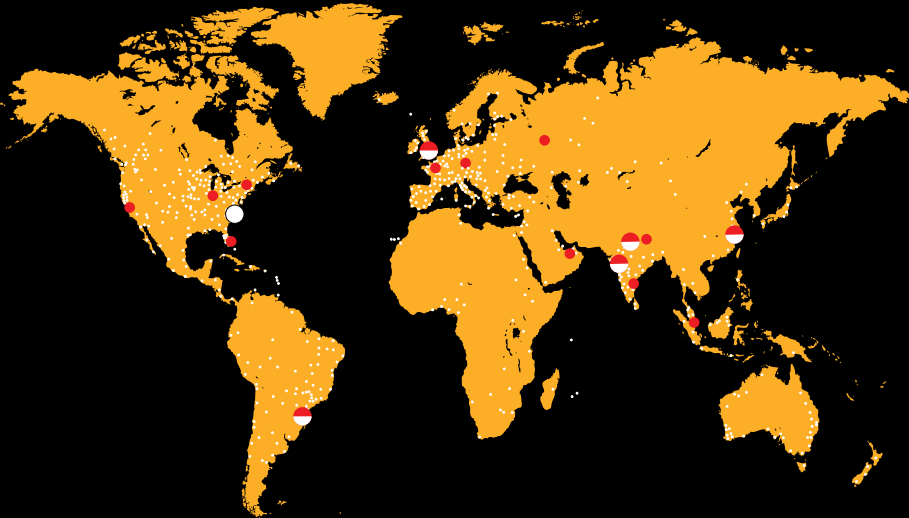

- Manufacturing Facilities
- Dealers
- Parts Distribution Centres

1 JCB Technical Support Service provides instant access to factory expertise, day or night. JCB's Finance team is always on hand to provide fast, flexible, competitive quotes.



2 The global network of JCB Parts Centers is a model of efficiency. Four JCB parts distribution centers in North America maintain 95 percent parts availability and 99 percent same-day dispatch. Genuine JCB parts work in perfect harmony with your machine for optimum performance and productivity.



*Note: JCB LIVELINK and JCB YELLOW SHIELD may not be available in your region. Please check with your local JCB dealer.*



## STATIC DIMENSIONS

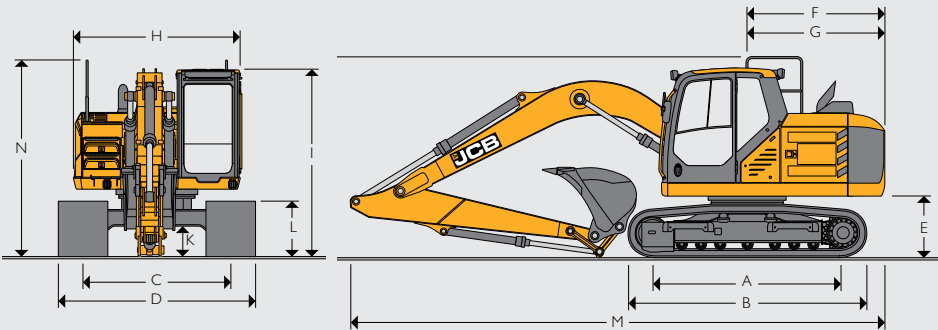

## STATIC DIMENSIONS

Model	I31X LC				
A	Track length on ground	ft-in (m)	9-5 (2.87)		
B	Undercarriage overall length	ft-in (m)	11-9 (3.59)		
C	Track gauge	ft-in (m)	6-6 (1.99)		
D	Width over tracks (500 mm trackshoes)	ft-in (m)	8-2 (2.49)		
D	Width over tracks (600 mm trackshoes)	ft-in (m)	8-6 (2.59)		
D	Width over tracks (700 mm trackshoes)	ft-in (m)	8-10 (2.69)		
D	Width over tracks (850 mm trackshoes)	ft-in (m)	9-4 (2.84)		
E	Counterweight clearance	ft-in (m)	3-0 (0.91)		
F	Tail length	ft-in (m)	6-11		
G	Tail swing radius	ft-in (m)	7-1		
H	Width of upper superstructure	ft-in (m)	8-2 (2.49)		
I	Height over cab	ft-in (m)	9-5 (2.87)		
I	Height over cab (vandal guard – optional)	ft-in (m)	10-5 (3.17)		
I	Height over cab (FOPS guard)	ft-in (m)	9-9 (2.97)		
J	Height over grab rail	ft-in (m)	9-10 (3.00)		
K	Ground clearance	ft-in (m)	1-5 (0.43)		
L	Track height	ft-in (m)	2-8 (0.81)		
			Mono		
			2.5 m	2.7 m	3.0 m
M	Transport length	ft-in (m)	25-2 (7.66)	25-1 (7.65)	24-11 (7.60)
N	Transport height	ft-in (m)	9-10 (3.00)	10-6 (3.21)	10-9 (3.29)

## ENGINE

Model	JCB EcoMAX 444 TCA EPA Tier 4 Final Compliant		
Type	4-stroke, 4-cylinder in-line, common rail, direct injection, turbocharged and intercooled diesel		
Rated power	hp (kW)	74 (55)	
Piston displacement	4.399 liters		
Air filtration	Dry element with secondary safety element and in cab warning indicator		
Starting system	24 volt		
Batteries	2 x 12 volt		
Alternator	28 volt – 100 ampere		
Max. torque	lb-ft (Nm)	295 (400)	
Bore and stroke	in (mm)	4 (103) & 5 (132)	

## SWING SYSTEM

Swing motor	Axial piston		
Swing brake	Hydraulic braking plus automatic spring applied disc type parking brake		
Swing torque	lbf (kNm)	26,552 (36)	
Swing speed	RPM	13.1	
Swing gear	Large diameter, internally toothed fully sealed grease bath lubricated		
Dipstick	Remote		

## TRACK DRIVE

Type	Fully hydrostatic, two speed with autoshift		
Travel motors	Variable swash axial piston type, fully guarded within undercarriage frame		
Final drive	Planetary reduction, bolt-on sprockets		
Service brake	Hydraulic counter balance valve		
Park brake	Disc type, spring applied, automatic hydraulic release		
Gradeability	70% (35 deg) continuous		
<b>Travel speed</b>	<b>LC</b>		
	mph (km/h)	4.1 (6.6)	
	mph (km/h)	2.4 (3.8)	
<b>Tractive effort</b>	lbf (km/h)	26,078 (116)	

## HYDRAULIC SYSTEM

Pumps			
Main pumps		2 variable displacement axial piston type	
Max. flow	gpm (l/min)	2 x 34.3 (2 x 130)	
Servo pump	gpm (l/min)	7.9 (30)	
Control valve			
A combined four and five spool control valve with auxiliary service spool as standard			
Relief valve settings			
Boom/arm/bucket	psi (bar)	4,554 (314)	
With power boost	psi (bar)	4,975 (343)	
Swing circuit	psi (bar)	4,047 (279)	
Travel circuit	psi (bar)	4,975 (343)	
Pilot control	psi (bar)	580 (40)	
Filtration			
In tank		105 micron, suction strainer	
Main return line		10 micron, glass fibre element	
Pilot drain line		10 micron, glass fibre element	
Pilot line		10 micron, glass fibre element	
Hydraulic hammer return		10 micron, reinforced microform element	
Hydraulic cylinders			
	Quantity	Bore in (mm)	Rod diameter in (mm)
Boom	2	3.9 (100)	3.0 (75)
Arm	1	4.5 (115)	3.1 (80)
Bucket	1	3.7 (95)	2.8 (70)
Tab	1	5.5 (140)	3.0 (75)

## SERVICE CAPACITIES

Fuel tank	g (l)	68.7 (260)
Engine coolant	g (l)	5.2 (19.7)
Engine oil	g (l)	3.7 (14)
Swing reduction gear	g (l)	0.5 (2.2)
Track reduction gear (each side)	g (l)	0.9 (3.5)
Hydraulic system	g (l)	33.3 (126)
Hydraulic tank	g (l)	35.1 (133)
DEF fluid	g (l)	12.6 (47.7)

## WORKING RANGE – MONOBOOM: 15' 5" (4.7 M)

Dipper length:	ft-in (mm)	6-10 (2.1)	8-2 (2.5)	8-10 (2.7)	9-10 (3.0)
A Max. digging reach	ft-in (mm)	26-4 (8,015)	27-6 (8,385)	28-1 (8,564)	29-0 (8,841)
B Max. digging reach (on ground)	ft-in (mm)	25-10 (7,863)	27-0 (8,240)	27-8 (8,422)	28-7 (8,704)
C Max. digging depth	ft-in (mm)	16-11 (5,161)	18-3 (5,564)	18-11 (5,764)	19-11 (6,063)
D Max. digging height	ft-in (mm)	29-3 (8,907)	30-1 (9,164)	30-6 (9,288)	31-2 (9,503)
E Max. dumping height	ft-in (mm)	21-0 (6,411)	21-11 (6,684)	22-4 (6,806)	23-0 (7,007)
F Max. vertical wall cut depth	ft-in (mm)	15-5 (4,698)	16-9 (5,098)	17-4 (5,295)	18-4 (5,592)
G Min. swing radius	ft-in (mm)	7-1 (2,156)	7-3 (2,212)	8-3 (2,506)	8-5 (2,575)
H Min. dumping height	ft-in (mm)	9-2 (2,795)	7-10 (2,393)	7-5 (2,267)	6-6 (1,975)
I Max. swing height	ft-in (mm)	21-1 (6,436)	22-0 (6,707)	22-5 (6,833)	23-1 (7,034)
J Min. swing height	ft-in (mm)	11-7 (3,525)	10-2 (3,108)	9-7 (2,922)	8-8 (2,630)
K Bucket struck radius	ft-in (mm)	4-1 (1,248)	4-1 (1,248)	4-1 (1,248)	4-1 (1,248)
L Bucket rotation	degrees	182	182	182	182
Max. dipper tearout	lbf (kgf)	16,299 (7,393)	14,522 (6,587)	142,09 (6,445)	13,197 (5,986)
Max. bucket tearout	lbf (kgf)	20,794 (9,432)	20,794 (9,432)	20,794 (9,432)	20,794 (9,432)

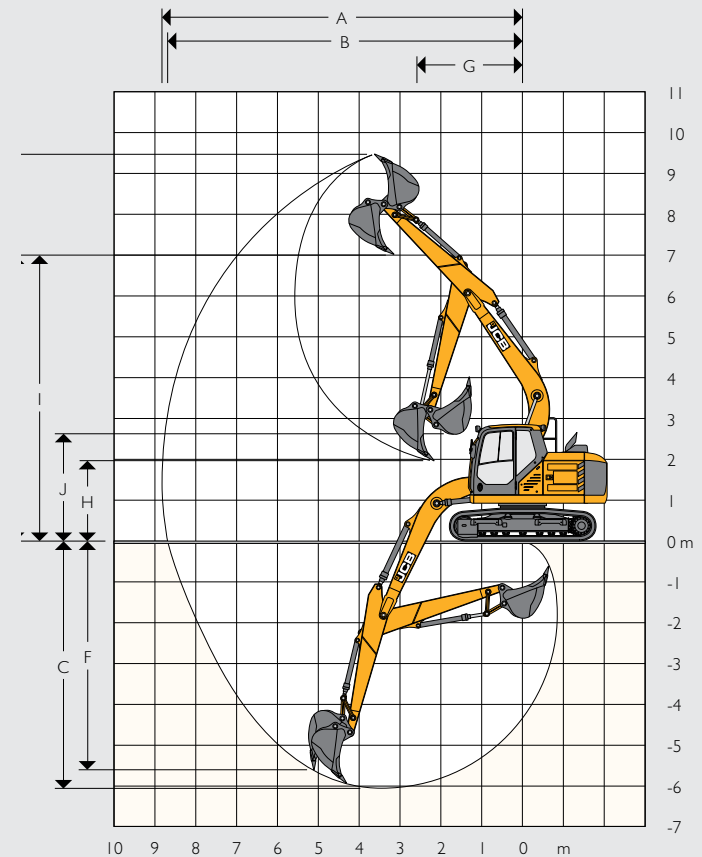



### UNDERCARRIAGE

Carriage options	LC – Long Carriage.				
Construction	Fully welded 'X' frame type with central bellyguarding and sloping sidemembers with dirt relief holes under top rollers.				
Recovery point	Front and rear.				
Track type	Sealed and lubricated.				
Upper and lower rollers	Heat treated, sealed and lubricated.				
Track adjustment	Grease cylinder type.				
Track idler	Sealed and lubricated, with spring cushioned recoil.				
Track shoe options	ft-in (mm)	20 (500)	24 (600)	28 (700)	33 (850)
		●▲■	●■	●	●
No. of upper rollers (per side)				2	
No. of lower rollers (per side)				7	
No. of track guides (per side)				2 optional	
No. of track shoes (per side)				44	

- TRIPLE GROUSER ●
- GEOGRIP ▲
- RUBBER SHOES ■

### WEIGHTS AND GROUND BEARING PRESSURES

Figures include standard 966 lb (438 kg), bucket, operator, full fuel tank and 8'2" (2.5 m) dipper.					
	ft-in (mm)	20 (500)	24 (600)	28 (700)	33 (850)
<b>131 LC Monoboom</b>					
Machine weight	lb (kg)	32,664 (14,816)	33,138 (15,031)	33,614 (15,247)	35,649 (16,170)
Ground bearing pressure	lb/in <sup>2</sup> (kg/cm <sup>2</sup> )	6.8 (0.48)	5.7 (0.40)	5.0 (0.35)	4.4 (0.31)

### SOUND LEVEL

Sound level in cab according to ISO 6396	67 dB(A)
External sound level according to ISO 6395 and EU Directive 2000/14/EC	102 dB(A)

### BUCKET AND ARM COMBINATION

Bucket options	GP Bucket										HD Bucket					Ditch Maintenance		HD Bucket					
	18 (450)	24 (600)	28 (700)	31 (800)	35 (900)	39 (1000)	49 (1250)	53 (1350)	18 (458)	24" (610)	30 (762)	36 (915)	39 (991)	48 (1,219)	60 (1524)	72 (1836)	24 (600)	28 (700)	31 (800)	1000	1200	1300	
Bucket width in (mm)	18 (450)	24 (600)	28 (700)	31 (800)	35 (900)	39 (1000)	49 (1250)	53 (1350)	18 (458)	24" (610)	30 (762)	36 (915)	39 (991)	48 (1,219)	60 (1524)	72 (1836)	24 (600)	28 (700)	31 (800)	1000	1200	1300	
Bucket capacity ft <sup>3</sup> (m <sup>3</sup> )	7.4 (0.21)	12.4 (0.35)	14.8 (0.42)	17.7 (0.50)	19.1 (0.54)	23.3 (0.66)	28.6 (0.81)	31.4 (0.89)	7.1 (0.20)	9.2 (0.26)	12.0 (0.34)	15.2 (0.43)	17.7 (0.50)	21.5 (0.61)	23.0 (0.65)	27.9 (0.79)	12.4 (0.35)	14.8 (0.42)	17.7 (0.50)	0.66	0.81	0.89	
Bucket weight lb (kg)	677(307)	754 (342)	807 (366)	884 (401)	937 (425)	1014 (460)	1,116 (506)	1,195 (542)	606 (275)	683 (310)	787 (357)	886 (402)	935 (424)	1,087(493)	1,047 (475)	1,179 (535)	741 (336)	802 (364)	886 (402)	455	520	547	
<b>131X LC</b>																							
2.1 m quick hitch (no quick hitch)	☐ (☐)	☐ (☐)	☐ (☐)	☐ (☐)	☐ (☐)	☐ (☐)	☐ (■)	■ (■)	☐ (☐)	☐ (☐)	☐ (☐)	☐ (☐)	☐ (☐)	☐ (☐)	☐ (☐)	☐ (■)	☐ (☐)	☐ (☐)	☐ (☐)	☐ (☐)	☐ (■)	■ (■)	
2.5 m quick hitch (no quick hitch)	☐ (☐)	☐ (☐)	☐ (☐)	☐ (☐)	☐ (☐)	☐ (☐)	☐ (■)	■ (●)	☐ (☐)	☐ (☐)	☐ (☐)	☐ (☐)	☐ (☐)	☐ (☐)	☐ (☐)	☐ (■)	☐ (☐)	☐ (☐)	☐ (☐)	☐ (☐)	■ (■)	■ (●)	
2.7 m quick hitch (no quick hitch)	☐ (☐)	☐ (☐)	☐ (☐)	☐ (☐)	☐ (☐)	☐ (☐)	■ (●)	■ (●)	☐ (☐)	☐ (☐)	☐ (☐)	☐ (☐)	☐ (☐)	☐ (☐)	☐ (☐)	■ (●)	☐ (☐)	☐ (☐)	☐ (☐)	☐ (☐)	■ (●)	■ (●)	
3.0 m quick hitch (no quick hitch)	☐ (☐)	☐ (☐)	☐ (☐)	☐ (☐)	☐ (☐)	☐ (■)	■ (●)	● (×)	☐ (☐)	☐ (☐)	☐ (☐)	☐ (☐)	☐ (☐)	☐ (☐)	☐ (■)	■ (●)	☐ (☐)	☐ (☐)	☐ (☐)	☐ (☐)	☐ (■)	■ (●)	● (×)
<b>131X LCD</b>																							
2.1 m quick hitch (no quick hitch)	☐ (☐)	☐ (☐)	☐ (☐)	☐ (☐)	☐ (☐)	☐ (☐)	☐ (☐)	☐ (■)	☐ (☐)	☐ (☐)	☐ (☐)	☐ (☐)	☐ (☐)	☐ (☐)	☐ (☐)	☐ (☐)	☐ (☐)	☐ (☐)	☐ (☐)	☐ (☐)	☐ (☐)	☐ (■)	
2.5 m quick hitch (no quick hitch)	☐ (☐)	☐ (☐)	☐ (☐)	☐ (☐)	☐ (☐)	☐ (☐)	☐ (■)	■ (■)	☐ (☐)	☐ (☐)	☐ (☐)	☐ (☐)	☐ (☐)	☐ (☐)	☐ (☐)	☐ (■)	☐ (☐)	☐ (☐)	☐ (☐)	☐ (☐)	☐ (■)	■ (●)	
2.7 m quick hitch (no quick hitch)	☐ (☐)	☐ (☐)	☐ (☐)	☐ (☐)	☐ (☐)	☐ (☐)	☐ (■)	■ (●)	☐ (☐)	☐ (☐)	☐ (☐)	☐ (☐)	☐ (☐)	☐ (☐)	☐ (☐)	☐ (■)	☐ (☐)	☐ (☐)	☐ (☐)	☐ (☐)	☐ (■)	■ (●)	
3.0 m quick hitch (no quick hitch)	☐ (☐)	☐ (☐)	☐ (☐)	☐ (☐)	☐ (☐)	☐ (☐)	■ (●)	● (●)	☐ (☐)	☐ (☐)	☐ (☐)	☐ (☐)	☐ (☐)	☐ (☐)	☐ (☐)	■ (●)	☐ (☐)	☐ (☐)	☐ (☐)	☐ (☐)	☐ (■)	● (●)	

- ☐ = Suitable for general excavating materials up to 1,800kg/m<sup>3</sup>.
- = Suitable for grading and loading materials up to 1,500kg/m<sup>3</sup>.
- = Suitable for light excavating materials up to 1,200kg/m<sup>3</sup>.
- × = Not recommended.

These recommendations are given as a guide based on typical operating conditions. Please contact your distributor for the correct selection of buckets and attachments to suit the application.











**STANDARD/OPTIONAL EQUIPMENT**

<b>ENGINE</b>		<b>CAB &amp; INTERIOR</b>		<b>HYDRAULIC SYSTEM</b>	
JCB, Tier 4 Final-compliant, water cooled diesel turbocharged after cooled electronic 4 cylinder 4.4 liter engine.	•	Sound-insulated and dual-shock mounted cab	•	Bucket regeneration	•
Start pre-heat	•	Mechanical suspension seat	•	One touch power boost	•
One touch idle	•	Heater	•	Cushion control	•
Auto-idle function	•	Opening front window and removable lower front window	•	Cylinder cushioning and contamination seals	•
Automatic engine shutdown	•	Upper door sliding glass in 2 directions	•	2-speed track motors	•
Fan guard	•	Upper windscreen wiper	•	Oil cooler	•
Heavy duty batteries	•	4-button joysticks	•	10 attachment settings through the display	•
Fuel filter with sedimenter	•	Travel pedals and T-handle levers	•	High, merged, medium and low flow options (shut off taps as standard)	+
Electronic engine control	•	2 foot rests	•	Advanced tool select to control flow and pressure	+
Fuel cooler	•	Immobiliser	+	Proportional control joystick sliders with electronic foot pedal	+
Refuelling pump with inline filter	+	Loudspeakers and connection for radio	•	Bio oil	+
Additional fuel filter with water separator	•	Standard cab filtration	•	Panolin oil	+
Reversing fan	+	Electric dual tone horn	•	Quick hitch pipework	+
Webasto winter kit	+	Interior cab light	•	Hydraulic quick hitch	+
<b>SAFETY</b>		3 x 12v sockets	•	ISO/SAE change over	+
Side guard rails on upper structure and steps	•	7" colour monitor	•	SAE to BSP converters on high flow auxiliary pipework	+
Rear view camera	•	Retractable 2" seatbelt	•	Quick release couplings	+
Battery isolator	•	Fixed roof glass	•	Hose burst check valves (boom, arm)	+
Key	•	Roof blind	•	Twin HBCV For bucket cylinder	+
Lockable fuel cap	•	Cool box	•	Auxiliary vent to tank	+
Lockable hydraulic tank cap	•	Cup holder	•	Attachment case drain	+
Work lights (Level 1 – 2 revolving frame, 2 boom mounted)	•	Climate control	+	Steelwrist ready	+
Roll over protective structure (ROPS)	•	Rear window blind	+	<b>DIG END</b>	
Travel alarm	•	3" seat belt	+	Grouped greasing	•
Additional light options (levels 2 & 3 available in halogen or LED)	+	2" hi-vis seat belt	+	Auto greasing	+
White noise alarm	+	3" hi-vis seat belt	+	Dippers 8'2" (2.5 m), 8'10" (2.7 m), 9'10" (3.0 m)	+
Cab guard	+	Front blind	+	HD dipper 8'10" (2.7 m), 9'10" (3.0 m)	+
Green beacon linked to seat belt	+	Side window blind	+	Lifting hook tipping link	+
Fire extinguisher (1 kg powder)	+	Bluetooth radio (linked to pod controls and screen)	+	Lifting shackle tipping link	+
Vandal guards	+	Carbon air filter	+	Bucket ram guard	+
Chevron counterweight	+	Deluxe seat: heated, adjustable air suspension seat with adjustable headrest.	+	Guards for boom mounted lights	+
Rotating roof beacon	+	Super deluxe seat: Heated and air ventilation, adjustable air suspension seat with adjustable head rest and electric lumbar support	+	<b>OTHER</b>	
2 x counterweight beacons	+	Rain guard visor	+	Ground level visible hour meter	•
Twin camera	+	Dual front wiper	+	Large toolbox	•
360 degree camera	+	<b>UNDERCARRIAGE</b>		Livelihood telematics	•
Full upper surrounding handrails	+	Greased and sealed track links	•	Wide core radiators	+
Arm limiter	+	Twin track guards	+	HD slew bearing seal	+
		24" (600 mm), 28" (700 mm), 31" (800 mm), 34" (850 mm) triple grouser shoe	+	10mm heavy duty plates for upper and lower structure	+
		20" (500 mm), 24" (600 mm), 28" (700 mm) dozer	+	Flyscreen (cooling pack + condenser)	+
				Guards for work lights	+
				Service bay & access lighting	+
				TOPCON / LIECA / TRIMBLE –GPS ready	+











**STANDARD** •  
**OPTIONAL** +













**LIFT CAPACITIES - DIPPER LENGTH: 6'10" (2.1 M), MONOBOOM: 15'5" (4.7 M), TRACKSHOES: 20" (500 MM), NO BUCKET - I3IX LC MONO**

Reach ft-in (m)	9-10 (3)		13-1 (4)		16-5 (5)		19-8 (6)		Capacity at Max. Reach		ft-in (mm)
											
Load point height ft-in (mm)	lb (kg)	lb (kg)	lb (kg)	lb (kg)	lb (kg)	lb (kg)	lb (kg)	lb (kg)	lb (kg)	lb (kg)	
19-8 (6)	-	-	7,077 (3,210)	7,077 (3,210)	6,504 (2,950)	6,504 (2,950)	-	-	6,482 (2,940)	6,482 (2,940)	16-5 (5,001)
14-9 (4.5)	8,554 (3,880)	8,554 (3,880)	7,826 (3,550)	7,826 (3,550)	7,430 (3,370)	7,430 (3,370)	6,371 (2,890)	5,842 (2,650)	5,930 (2,690)	5,798 (2,630)	19-9 (6,027)
9-10 (3)	13,206 (5990)	13,206 (5,990)	10,009 (4,540)	10,009 (4,540)	8,532 (3,870)	7,540 (3,420)	7,760 (3,520)	5,754 (2,610)	5,864 (2,660)	4,982 (2,260)	21-6 (6,562)
4-11 (1.5)	-	-	12,456 (5,650)	9,789 (4,440)	9,899 (4,490)	7,165 (3,250)	8,179 (3,710)	5,556 (2,520)	6,151 (2,790)	4,696 (2,130)	22-1 (6,726)
0	14,088 (6,390)	14,088 (6,390)	13,713 (6,220)	9,414 (4,270)	10,428 (4,730)	6,923 (3,140)	8,025 (3,640)	5,401 (2,450)	6,878 (3,120)	4,806 (2,180)	21-6 (6,547)
-4-11 (-1.5)	17,725 (8,040)	14,462 (6,560)	13,536 (6,140)	9,326 (4,230)	10,340 (4,690)	6,834 (3,100)	-	-	8,025 (3,640)	5,401 (2,450)	19-8 (5,994)
-9-10 (-3)	14,969 (6,790)	14,749 (6,690)	11,596 (5,260)	9,502 (4,310)	-	-	-	-	8,730 (3,960)	7,143 (3,240)	16-3 (4,941)

**LIFT CAPACITIES - DIPPER LENGTH: 8'2" (2.5 M), MONOBOOM: 15'5" (4.7 M), TRACKSHOES: 20" (500 MM), NO BUCKET - I3IX LC MONO**

Reach ft-in (m)	9-10 (3)		13-1 (4)		16-5 (5)		19-8 (6)		Capacity at Max. Reach		ft-in (mm)
											
Load point height ft-in (mm)	lb (kg)	lb (kg)	lb (kg)	lb (kg)	lb (kg)	lb (kg)	lb (kg)	lb (kg)	lb (kg)	lb (kg)	
19-8 (6)	-	-	6,129 (2,780)	6,129 (2,780)	6,548 (2,970)	6,548 (2,970)	-	-	5,181 (2,350)	5,181 (2,350)	18-0 (5,491)
14-9 (4.5)	-	-	6,967 (3,160)	6,967 (3,160)	6,768 (3,070)	6,768 (3,070)	6,768 (3,070)	5,930 (2,690)	4,806 (2,180)	4,806 (2,180)	21-1 (6,438)
9-10 (3)	11,640 (5,280)	11,640 (5,280)	9,171 (4,160)	9,171 (4,160)	7,959 (3,610)	7,606 (3,450)	7,297 (3,310)	5,776 (2,620)	4,762 (2,160)	4,586 (2,080)	22-9 (6,942)
4-11 (1.5)	16,689 (7,570)	15,080 (6,840)	11,794 (5,350)	9,899 (4,490)	9,436 (4,280)	7,209 (3,270)	8,135 (3,690)	5,556 (2,520)	5,004 (2,270)	4,343 (1,970)	23-3 (7,096)
0	15,631 (7,090)	14,418 (6,540)	13,448 (6,100)	9,414 (4,270)	10,428 (4,730)	6,900 (3,130)	8,003 (3,630)	5,379 (2,440)	5,556 (2,520)	4,409 (2,000)	22-9 (6,927)
-4-11 (-1.5)	18,188 (8,250)	14,330 (6,500)	13,669 (6,200)	9,259 (4,200)	10,274 (4,660)	6,768 (3,070)	7,915 (3,590)	5,313 (2,410)	6,680 (3,030)	4,872 (2,210)	21-0 (6,407)
-9-10 (-3)	16,028 (7,270)	14,551 (6,600)	12,302 (5,580)	9,370 (4,250)	9,546 (4,330)	6,878 (3,120)	-	-	8,333 (3,780)	6,173 (2,800)	17-10 (5,436)

**LIFT CAPACITIES - DIPPER LENGTH: 8'10" (2.7 M), MONOBOOM: 15'5" (4.7 M), TRACKSHOES: 20" (500 MM), NO BUCKET - I3IX LC MONO**

Reach ft-in (m)	9-10 (3)		13-1 (4)		16-5 (5)		19-8 (6)		Capacity at Max. Reach		ft-in (mm)
											
Load point height ft-in (mm)	lb (kg)	lb (kg)	lb (kg)	lb (kg)	lb (kg)	lb (kg)	lb (kg)	lb (kg)	lb (kg)	lb (kg)	
19-8 (6)	-	-	5,666 (2,570)	5,666 (2,570)	6,129 (2,780)	6,129 (2,780)	-	-	5,445 (2,470)	5,445 (2,470)	18-0 (5,491)
14-9 (4.5)	-	-	6,526 (2,960)	6,526 (2,960)	6,437 (2,920)	6,437 (2,920)	6,592 (2,990)	5,975 (2,710)	5,071 (2,300)	5,027 (2,280)	21-1 (6,438)
9-10 (3)	10,825 (4,910)	10,825 (4,910)	8,708 (3,950)	8,708 (3,950)	7,650 (3,470)	7,628 (3,460)	7,033 (3,190)	5,798 (2,630)	5,049 (2,290)	4,387 (1,990)	22-9 (6,942)
4-11 (1.5)	15,984 (7,250)	15,146 (6,870)	11,398 (5,170)	9,921 (4,500)	9,171 (4,160)	7,209 (3,270)	7,937 (3,600)	5,556 (2,520)	5,313 (2,410)	4,167 (1,890)	23-3 (7,096)
0	16,072 (7,290)	14,352 (6,510)	13,206 (5,990)	9,370 (4,250)	10,362 (4,700)	6,878 (3,120)	7,959 (3,610)	5,335 (2,420)	5,864 (2,660)	4,211 (1,910)	22-9 (6,927)
-4-11 (-1.5)	18,276 (8,290)	14,198 (6,440)	13,625 (6,180)	9,171 (4,160)	10,229 (4,640)	6,724 (3,050)	7,871 (3,570)	5,247 (2,380)	6,900 (3,130)	4,630 (2,100)	21-0 (6,407)
-9-10 (-3)	16,380 (7,430)	14,396 (6,530)	12,522 (5,680)	9,259 (4,200)	9,811 (4,450)	6,768 (3,070)	-	-	8,113 (3,680)	5,776 (2,620)	17-10 (5,436)



Lift capacity front and rear.













Lift capacity full circle.











**Notes:**

- Lifting capacities are based on ISO 10567, that is: 75% of minimum tipping load or 87% of hydraulic lift capacity, whichever is the less. Lifting capacities marked\* are based on hydraulic capacity.
- Lift capacities assume that the machine is on firm, level ground.
- Lift capacities may be limited by local regulations. Please refer to your dealer.











**LIFT CAPACITIES - DIPPER LENGTH: 9'10" (3.0 M), MONOBOOM: 15'5" (4.7 M), TRACKSHOES: 20" (500 MM), NO BUCKET - I3IX LC MONO**

Reach ft-in (m)	9-10 (3)		13-1 (4)		16-5 (5)		19-8 (6)		Capacity at Max. Reach		
											ft-in (mm)
Load point height ft-in (mm)	lb (kg)	lb (kg)	lb (kg)	lb (kg)	lb (kg)	lb (kg)	lb (kg)	lb (kg)	lb (kg)	lb (kg)	ft-in (mm)
19-8 (6)	-	-	-	-	5,556 (2,520)	5,556 (2,520)	5,269 (2,390)	5,269 (2,390)	47,62 (2,160)	4,762 (2,160)	19-11 (6,072)
14-9 (4.5)	-	-	5,864 (2,660)	5,864 (2,660)	5,930 (2,690)	5,930 (2,690)	5,997 (2,720)	5,997 (2,720)	4,475 (2,030)	4,475 (2,030)	22-9 (6,940)
9-10 (3)	9,656 (4,380)	9,656 (4,380)	8,047 (3,650)	8,047 (3,650)	7,187 (3,260)	7,187 (3,260)	6,680 (3,030)	5,820 (2,640)	4,453 (2,020)	4,145 (1,880)	24-4 (7,409)
4-11 (1.5)	14,991 (6,800)	14,991 (6,800)	10,825 (4,910)	10,009 (4,540)	8,796 (3,990)	7,253 (3,290)	7,628 (3,460)	5,556 (2,520)	4,674 (2,120)	3,924 (1,780)	24-9 (7,554)
0	17,218 (7,810)	14,374 (6,520)	12,875 (5,840)	9,392 (4,260)	10,119 (4,590)	6,878 (3,120)	7,959 (3,610)	5,335 (2,420)	5,137 (2,330)	3,968 (1,800)	24-3 (7,395)
-4-11 (-1.5)	18,365 (8,330)	14,110 (6,400)	13,580 (6,160)	9,127 (4,140)	10,185 (4,620)	6,680 (3,030)	7,826 (3,550)	5,203 (2,360)	6,063 (2,750)	4,321 (1,960)	22-8 (6,911)
-9-10 (-3)	16,909 (7,670)	14,242 (6,460)	12,831 (5,820)	9,149 (4,150)	10,097 (4,580)	6,680 (3,030)	7,826 (3,550)	5,269 (2,390)	7,782 (3,530)	5,247 (2,380)	19-9 (6,023)

**LIFT CAPACITIES - DIPPER LENGTH: 6'10" (2.1 M), MONOBOOM: 15'5" (4.7 M), TRACKSHOES: 20" (500 MM), NO BUCKET - I3IX LCD MONO**

Reach ft-in (m)	9-10 (3)		13-1 (4)		16-5 (5)		19-8 (6)		Capacity at Max. Reach		
											ft-in (mm)
Load point height ft-in (mm)	lb (kg)	lb (kg)	lb (kg)	lb (kg)	lb (kg)	lb (kg)	lb (kg)	lb (kg)	lb (kg)	lb (kg)	ft-in (mm)
19-8 (6)	-	-	7,077 (3,210)	7,077 (3,210)	65,04 (2,950)	6,504 (2,950)	-	-	6,482 (2,940)	6,482 (2,940)	16-5 (5,001)
14-9 (4.5)	8,554 (3,880)	8,554 (3,880)	7,826 (3,550)	7,826 (3,550)	7,430 (3,370)	7,430 (3,370)	6,371 (2,890)	6,129 (2,780)	5,930 (2,690)	5,930 (2,690)	19-9 (6,027)
9-10 (3)	13,206 (5,990)	13,206 (5,990)	10,009 (4,540)	10,009 (4,540)	8,532 (3,870)	7,893 (3,580)	7,760 (3,520)	6,019 (2,730)	5,864 (2,660)	5,247 (2,380)	21-6 (6,562)
4-11 (1.5)	-	-	12,456 (5,650)	10,251 (4,650)	9,899 (4,490)	7,518 (3,410)	8,488 (3,850)	5,820 (2,640)	6,151 (2,790)	4,938 (2,240)	22-1 (6,726)
0	14,088 (6,390)	14,088 (6,390)	13,713 (6,220)	9,877 (4,480)	1,078 (4,890)	7,253 (3,290)	8,466 (3,840)	5,688 (2,580)	6,878 (3,120)	5,049 (2,290)	21-6 (6,547)
-4-11 (-1.5)	17,725 (8,040)	15,168 (6,880)	13,536 (6,140)	9,789 (4,440)	1,0737 (4,870)	7,187 (3,260)	-	-	8,422 (3,820)	5,688 (2,580)	19-8 (5,994)
-9-10 (-3)	14,969 (6,790)	1,4969 (6790)	11,596 (5,260)	9,965 (4,520)	-	-	-	-	8,730 (3,960)	7,496 (3,400)	16-3 (4,941)

**LIFT CAPACITIES - DIPPER LENGTH: 8'2" (2.5 M), MONOBOOM: 15'5" (4.7 M), TRACKSHOES: 20" (500 MM), NO BUCKET - I3IX LCD MONO**

Reach ft-in (m)	9-10 (3)		13-1 (4)		16-5 (5)		19-8 (6)		Capacity at Max. Reach		
											ft-in (mm)
Load point height ft-in (mm)	lb (kg)	lb (kg)	lb (kg)	lb (kg)	lb (kg)	lb (kg)	lb (kg)	lb (kg)	lb (kg)	lb (kg)	ft-in (mm)
19-8 (6)	-	-	6,129 (2,780)	6,129 (2,780)	6,548 (2,970)	6,548 (2,970)	0 (0)	0 (0)	5,181 (2,350)	5,181 (2,350)	12,106 (5,491)
14-9 (4.5)	-	-	6,967 (3,160)	6,967 (3,160)	6,768 (3,070)	6,768 (3,070)	6,768 (3,070)	6,217 (2,820)	4,806 (2,180)	4,806 (2,180)	14,193 (6,438)
9-10 (3)	11,640 (5,280)	11,640 (5,280)	9,171 (4,160)	9,171 (4,160)	7,959 (3,610)	7,959 (3,610)	7,297 (3,310)	6,063 (2,750)	4,762 (2,160)	4,762 (2,160)	15,304 (6,942)
4-11 (1.5)	166,89 (7,570)	15,785 (7,160)	11,795 (5,350)	10,362 (4,700)	9,436 (4,280)	7,562 (3,430)	8,135 (3,690)	5,842 (2,650)	5,004 (2,270)	4,564 (2,070)	15,644 (7,096)
0	15,631 (7,090)	15,124 (6,860)	13,448 (6,100)	9,877 (4,480)	10,560 (4,790)	7,253 (3,290)	8,444 (3,830)	5,644 (2,560)	5,556 (2,520)	4,630 (2,100)	15,271 (6,927)
-4-11 (-1.5)	18,188 (8,250)	15,036 (6,820)	13,669 (6,200)	9,722 (4,410)	10,803 (4,900)	7,121 (3,230)	8,378 (3,800)	5,578 (2,530)	6,680 (3,030)	5,137 (2,330)	14,125 (6,407)
-9-10 (-3)	16,028 (7,270)	15,256 (6,920)	12,302 (5,580)	9,833 (4,460)	9,546 (4,330)	7,209 (3,270)	0 (0)	0 (0)	8,333 (3,780)	6,482 (2,940)	119,84 (5,436)



Lift capacity front and rear.













Lift capacity full circle.

**Notes:**











- Lifting capacities are based on ISO 10567, that is: 75% of minimum tipping load or 87% of hydraulic lift capacity, whichever is the less. Lifting capacities marked\* are based on hydraulic capacity.
- Lift capacities assume that the machine is on firm, level ground.
- Lift capacities may be limited by local regulations. Please refer to your dealer.



**LIFT CAPACITIES - DIPPER LENGTH: 8'10" (2.7 M), MONOBOOM: 15'5" (4.7 M), TRACKSHOES: 20" (500 MM), NO BUCKET - I3IX LCD MONO**

Reach ft-in (m)	9-10 (3)		13-1 (4)		16-5 (5)		19-8 (6)		Capacity at Max. Reach			
												ft-in (mm)
Load point height ft-in (mm)	lb (kg)	lb (kg)	lb (kg)	lb (kg)	lb (kg)	lb (kg)	lb (kg)	lb (kg)	lb (kg)	lb (kg)	lb (kg)	ft-in (mm)
19-8 (6)	-	-	5,666 (2,570)	5,666 (2,570)	6,129 (2,780)	6,129 (2,780)	-	-	5,445 (2,470)	5,445 (2,470)	5,445 (2,470)	18-9 (5,721)
14-9 (4.5)	-	-	6,526 (2,960)	6,526 (2,960)	6,437 (2,920)	6,437 (2,920)	6,437 (2,920)	6,239 (2,830)	5,071 (2,300)	5,071 (2,300)	5,071 (2,300)	21-9 (6,635)
9-10 (3)	10,825 (4,910)	10,825 (4,910)	8,708 (3,950)	8,708 (3,950)	7,650 (3,470)	7,650 (3,470)	7,033 (3,190)	6,063 (2,750)	5,049 (2,290)	4,630 (2,100)	4,630 (2,100)	23-4 (7,124)
4-11 (1.5)	15,984 (7,250)	15,851 (7,190)	11,398 (5,170)	10,384 (4,710)	9,171 (4,160)	7,562 (3,430)	7,937 (3,600)	5,820 (2,640)	5,313 (2,410)	4,387 (1,990)	4,387 (1,990)	23-10 (7,275)
0	16,072 (7,290)	15,058 (6,830)	13,206 (5,990)	9,833 (4,460)	10,362(4,700)	7,209 (3,270)	8,400 (3,810)	5,622 (2,550)	5,864 (2,660)	4,453 (2,020)	4,453 (2,020)	23-4 (7,110)
-4-11 (- 1.5)	18,276 (8,290)	14,903 (6,760)	13,625 (6,180)	9,634 (4,370)	10,759 (4,880)	7,055 (3,200)	7,430 (3,370)	5,534 (2,510)	6,989 (3,170)	4,894 (2,220)	4,894 (2,220)	21-8 (6,605)
-9-10 (- 3)	16,380 (7,430)	15,102 (6,850)	12,522 (5,680)	9,722 (4,410)	9,811 (4,450)	7,121 (3,230)	-	-	8,113 (3,680)	6,063 (2,750)	6,063 (2,750)	18-7 (5,668)

**LIFT CAPACITIES - DIPPER LENGTH: 9'10" (3.0 M), MONOBOOM: 15'5" (4.7 M), TRACKSHOES: 20" (500 MM), NO BUCKET - I3IX LCD MONO**

Reach ft-in (m)	9-10 (3)		13-1 (4)		16-5 (5)		19-8 (6)		Capacity at Max. Reach			
												ft-in (mm)
Load point height ft-in (mm)	lb (kg)	lb (kg)	lb (kg)	lb (kg)	lb (kg)	lb (kg)	lb (kg)	lb (kg)	lb (kg)	lb (kg)	lb (kg)	ft-in (mm)
19-8 (6)	-	-	-	-	5,556 (2,520)	5,556 (2,520)	5,269 (2,390)	5,269 (2,390)	4,762 (2,160)	4,762 (2,160)	4,762 (2,160)	19-11 (6,072)
14-9 (4.5)	-	-	5,864 (2,660)	5,864 (2,660)	5,930 (2,690)	5,930 (2,690)	5,997 (2,720)	5,997 (2,720)	4,475 (2,030)	4,475 (2,030)	4,475 (2,030)	22-9 (6,940)
9-10 (3)	9,656 (4,380)	9,656 (4,380)	8,047 (3,650)	8,047 (3,650)	7,187 (3,260)	7,187 (3,260)	6,680 (3,030)	6,107 (2,770)	4,453 (2,020)	4,343 (1,970)	4,343 (1,970)	24-4 (7,409)
4-11 (1.5)	14,991 (6,800)	14,991 (6,800)	10,825 (4,910)	10,472 (4,750)	8,796 (3,990)	7,584 (3,440)	7,628 (3,460)	5,842 (2,650)	4,674 (2,120)	4,123 (1,870)	4,123 (1,870)	24-9 (7,554)
0	17,218 (7,810)	15,080 (6,840)	12,875 (5,840)	9,855 (4,470)	10,119 (4,590)	7,209 (3,270)	8,400 (3,810)	5,600 (2,540)	5,137 (2,330)	4,167 (1,890)	4,167 (1,890)	24-3 (7,395)
-4-11 (- 1.5)	18,365 (8,330)	14,815 (6,720)	13,580 (6,160)	9,590 (4,350)	10,692 (4,850)	7,011 (3,180)	8,267 (3,750)	5,490 (2,490)	6,063 (2,750)	4,542 (2,060)	4,542 (2,060)	22-8 (6,911)
-9-10 (- 3)	16,909 (7,670)	14,947 (6,780)	12,831 (5,820)	9,612 (4,360)	10,097 (4,580)	7,033 (3,190)	7,826 (3,550)	5,556 (2,520)	7,782 (3,530)	5,534 (2,510)	5,534 (2,510)	19-9 (6,023)



Lift capacity front and rear.



Lift capacity full circle.

**Notes:**

1. Lifting capacities are based on ISO 10567, that is: 75% of minimum tipping load or 87% of hydraulic lift capacity, whichever is the less. Lifting capacities marked\* are based on hydraulic capacity.
2. Lift capacities assume that the machine is on firm, level ground.
3. Lift capacities may be limited by local regulations. Please refer to your dealer.

Your nearest JCB dealer

**JCB North America**

2000 Bamford Blvd., Pooler, Georgia, 31322 Tel: (912) 447-2000

Download the very latest information on this product range at [www.jcb.com](http://www.jcb.com)

JCB Inc. All rights reserved. No part of this publication may be reproduced, stored in a retrieval system, or transmitted in any form or by any other means, electronic, mechanical, photocopying or otherwise, without prior permission from JCB Inc. All references in this publication to operating weights, sizes, capacities and other performance measurements are provided for guidance only and may vary dependent upon the exact specification of machine. They should not therefore be relied upon in relation to suitability for a particular application. Guidance and advice should always be sought from your JCB Dealer. JCB reserves the right to change specifications without notice. Illustrations and specifications shown may include optional equipment and accessories. The JCB logo is a registered trademark of J C Bamford Excavators Ltd.

9999/6082 DWUSA 5310 07/19

 /JCBNA  /JCBNA  /JCBNORTHAMERICA

