



WHEEL LOADER | 457

Gross engine power: 282 hp (210 kW) Operating weight: 44,090 lb (19,999 kg) Full turn tipping load: 29,696 lb (13,470 kg)
Standard shovel capacity: 4.6 yd³ (3.5m³)



FULLY LOADED

The new Cummins powered JCB 457 wheel loaders are fully loaded with new and innovative features.

Unique 5-speed gearbox as standard with optional torque converter lock-up and one of the most comfortable and operator friendly cabs on the market with 2 new power modes for greater versatility.

With 50 years of proven wheel loader production, we're confident you'll be fully impressed with our latest model.





FULLY TESTED.

THE NEW JCB 457 HAS BEEN BUILT USING ONLY THE MOST ADVANCED PRODUCTION TECHNIQUES AND PREMIUM COMPONENTS FOR SUPERIOR STRUCTURAL STRENGTH. IT'S BEEN TESTED TO THE LIMIT ON SITES ALL OVER THE WORLD TO MAKE SURE THAT, WHEREVER YOU'RE OPERATING, YOU'LL MAINTAIN TOTAL PRODUCTIVITY AT ALL TIMES.

Designed to work harder.

1 Your new JCB 457 will have benefitted from finite element analysis and rig testing of up to 1 million cycles, to ensure superior structural strength and durability. For further peace of mind, cold cell testing guarantees starting performance down to -4°F.

2 High tolerances and accurate location of pins and bushes are guaranteed with JCB's precision machining techniques.

3 You can specify a 457 for heavy-duty applications like waste or corrosive material handling.

4 State-of-the-art manufacturing processes like robot machining, precision paint technology and innovative assembly techniques help achieve the very highest levels of build quality.



The 457's articulation joint has a heavy-duty box section that's much stronger than a single plate with a boss. Its steering rams are positioned high up and well protected from possible impact and site damage.

Designed to last.

5 A solid cast rear counterweight protects the rear of your 457, including the rear lights and cooling pack, from damage.

6 Hoses are neatly routed and clamped through the articulation joint, well away from any pinch points.

7 The articulation joint has a heavy-duty centre pin and oversized bush, as well as twin taper roller bearings on the bottom box joints. This enables it to tolerate both vertical and horizontal loadings for greater durability and rigidity.

8 New rear grille, cooling pack sealing and mudguard fitment for greater overall quality.

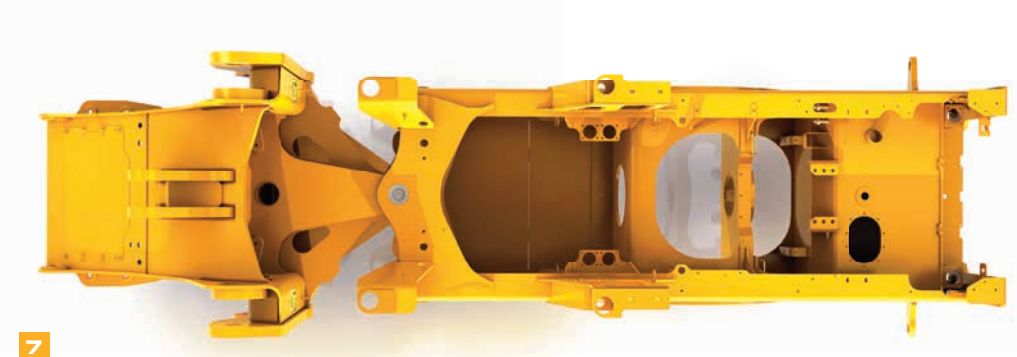

FULLY PRODUCTIVE.

TIME IS OF THE ESSENCE ON ANY WORKSITE SO THE NEW JCB 457 IS DESIGNED TO PROVIDE THE FASTEST CYCLE TIMES IN THE BUSINESS. POWERFUL TWIN HYDRAULIC PUMPS, A LOAD SENSING VALVE BLOCK AND 5-SPEED TRANSMISSION AS STANDARD WITH OPTIONAL TORQUE LOCK-UP, PROVIDE SPEED, ACCURACY AND PRODUCTIVITY IN ABUNDANCE.

Powering it all.

1 The Cummins B6.7-liter engine fitted to the new JCB 457 produces impressive performance with a substantial 210kW (282hp) of power; up 9% on our previous model, and 1350Nm of torque; up 17.4%. What's more, it produces all of this at low revs for an incredibly responsive operating experience.

A variable geometry turbocharger provides increased performance at low engine speed for improved cycle times and tractive effort.

Loading productivity.

2 Powerful twin variable displacement piston pump hydraulics can circulate a massive 306 l/min for fast cycle times and excellent multifunctional capability.

3 Choose the optional JCB Quickhitch and you'll find attachment changing is quick and efficient.

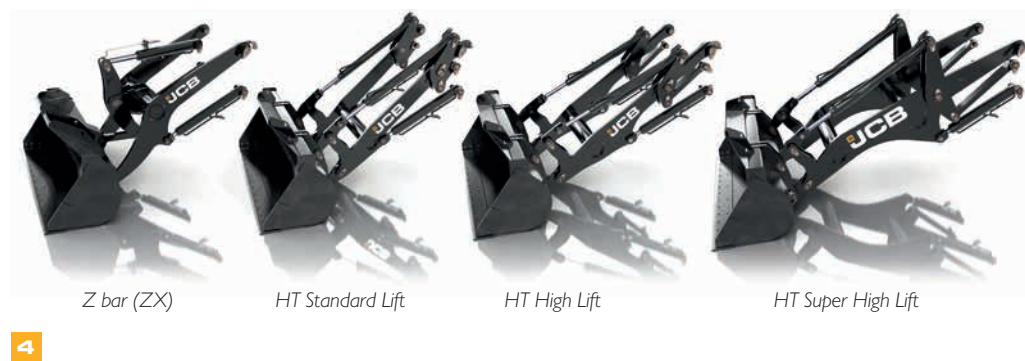

4 Specify your perfect loader arm: Z-bar linkage (ZX) for high breakout applications or high torque (HT) for parallel lifting and multi-attachment work. High lift or Super high lift option equips your 457 for applications involving high loading heights, such as hopper and lorry loading.

5 With maximum breakout forces of 176kN, this wheel loader has the power to carry out extremely arduous loading jobs.

Drivetrain productivity.

6 A unique 5-speed transmission is fitted as standard making operation even more slick, with closer gear ratios for improved acceleration, hill climbing and roading performance. An optional 5-speed transmission with torque convertor lock-up to eliminate losses, provides even faster cycle times and improved efficiency.

7 Tailor a 457 to any application with a range of axle options:

- > A limited slip differential is perfect for soft, muddy terrain with reduced traction.
- > Open differentials are ideal for hard standing ground conditions.
- > Open differentials with an automatic locking front diff provide excellent traction in varied ground conditions.

The innovative electronic management system can perform progressive clutch cut-off for efficient, productive loader control. This feature governs tractive effort via the transmission, diverting maximum power to the loader hydraulics while reducing service brake wear and fuel consumption.



FULLY POWERED.

POWER WITHOUT COMPROMISE HAS LONG BEEN THE ROLE OF ANY LARGE WHEEL LOADER AND THE NEW JCB 457 TAKES THIS ETHOS TO ANOTHER LEVEL. ITS CUTTING-EDGE CUMMINS ENGINE BOASTS POWER APLENTY, WHILE THE EFFICIENT, SMOOTH ZF DRIVELINE AND LOW FUEL CONSUMPTION HELP MAKE YOUR DECISION TO BUY JCB EVEN EASIER.

Driving efficiency.

- 1** The new JCB 457's Cummins engine offers you plenty of low-end torque and maintains it over a wide engine speed range.
- 2** A hydraulic cooling fan automatically reacts to ambient temperature and adjusts the 457's fan speed to optimise cooling and reduce fuel consumption. This also lowers noise on your site.
- 3** Opt for the torque lock up 5-speed transmission and you'll get 100% efficiency in second to fifth gears for improved fuel economy.
- 4** Two new power modes at the flick of a switch. Comfort Mode reduces engine power by 20% for light duty work to 224hp, helping to conserve fuel. Dynamic Mode increases power to a maximum 282hp for greater output.



Automatic idle returns the engine to 700rpm after 30 seconds of inactivity.



A new auto engine shutdown feature saves fuel by switching off the engine when the machine is left idling. Idle time can be set by the operator from the cab seat.

5 Wheel speed braking means the brakes on the new 457 rotate at the same speed as the wheels, for heat and drag reduction plus improved fuel economy.

6 Unloaded spool valves in the valve block allow the arms to lower under gravitation rather than hydraulic force; this reduces fuel consumption further still.

7 A choice of 3 or 4-spool hydraulics gives you the scope for invaluable extra versatility.

8 Selectable loader arm detents let operators control loader arm height limitations, return to dig settings and float functions, improving safety and productivity.



JCB's innovative variable displacement pumps feed a load-sensing valve block which only consumes power on demand, providing precise, efficient loader control.

COMMANDPLUS controls.
 JCB Smoothride load suspension limits shock loadings and therefore reduces material spillage and structural stress, as well as increasing operator comfort. The speed of engagement is adjustable from within the cab using the latest state-of-the-art CommandPlus controls.



6



7



8



FULLY IN COMMAND.

THE JCB COMMANDPLUS CAB IS ONE OF THE BEST CABS ON THE MARKET, WITH THE LATEST IN ERGONOMIC DESIGN PROVIDING AN OPTIMAL CONTROL LAYOUT AND DRIVER POSITION FOR GREATER COMFORT AND VISIBILITY, ENABLING EVEN GREATER OPERATOR PRODUCTIVITY.

See the difference.

1 The A-pillars are positioned to the same width to the rear of the cab, providing a larger interior with a superb panoramic front windscreen. All switches and auxiliary controls are located on the right-hand A-pillar for easier access.

2 Using the JCB 457's simple, dedicated menu interface is easily done with an intuitive optional rotary controller.

3 Controlling the loader is easy as all of the controls are seat-mounted and even move with the seat suspension. Simply select the control system that's best for your operators; we offer single lever joystick or multi-lever configurations.

4 There are two full color LCD screens to navigate your 457's operating menus, with one doubling as a monitor for the rear view camera.

For even greater operator comfort, the machine is equipped with end damped steering for smoother steering from lock to lock.



The noise level in the cab is an incredibly low 68dB(a): so quiet you can hardly hear the engine running.

5 To keep the operator environment comfortable for working at all times, we've positively pressurized the cab to eliminate dust and fumes.

6 After extensive research into operator ergonomics, we've devised the Command Driving Position, which provides the most optimal control layout for a multitude of different driver shapes and sizes. You can also choose from an air suspension standard seat to a super deluxe half leather seat, featuring fully adjustable heating and cooling functionality, electrically adjustable lumbar support and adjustable dampers.

7 A set and forget feature makes operator access even easier by storing your preferred steering wheel position. It can be instantly returned to, even after you've folded the wheel away.

Specify your 457 with either air conditioning or automatic climate control to create perfect working temperatures.

With a dedicated media port on board, you can be assured of superb connectivity for all your electronic devices.

A sliding window on both sides of the cab allows easy communication with people outside the machine.

The electronic handbrake offers numerous advantages: it's quick and easy to operate, and, because there's no cable, there are fewer holes in the cab. This helps to isolate the operator environment further.

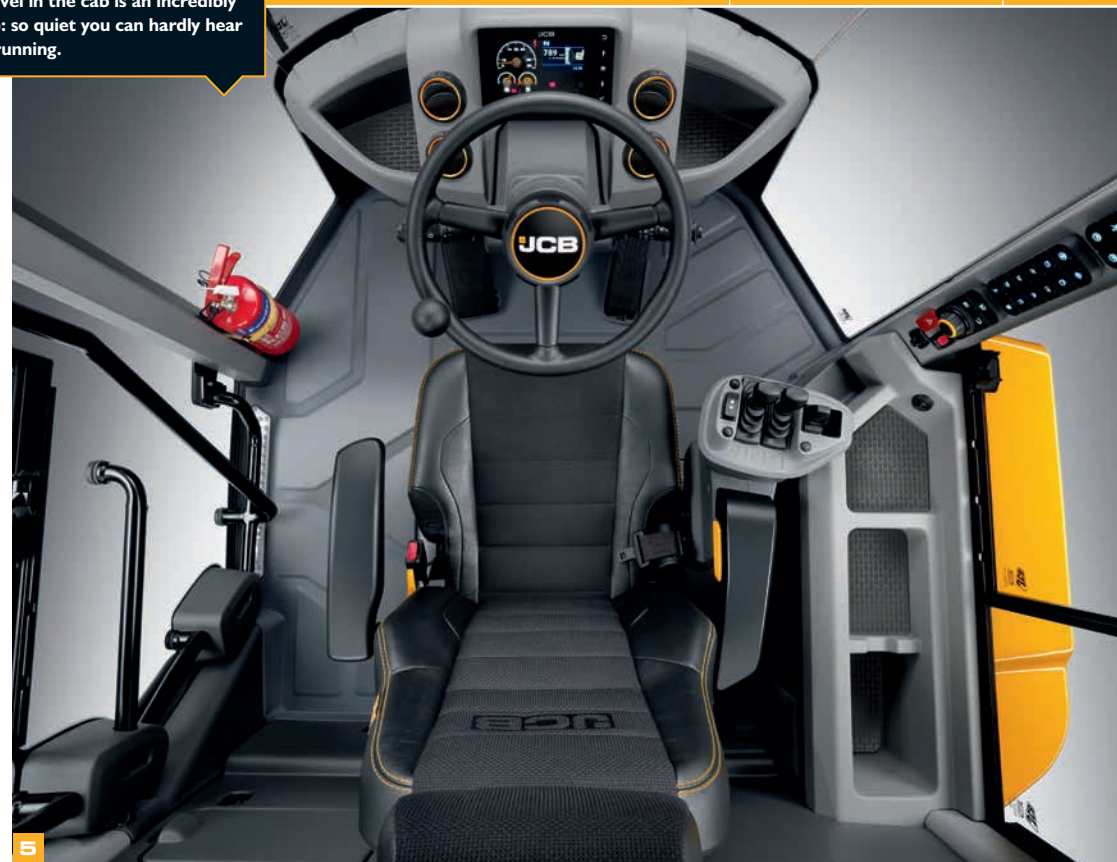

FULLY SERVICEABLE.

MAXIMISING YOUR FLEET'S UPTIME IS OUR NUMBER ONE PRIORITY AND WE'VE CERTAINLY PULLED OUT ALL THE STOPS ON THE NEW JCB 457. A ONE-PIECE HOOD, EASY GROUND LEVEL ACCESS TO KEY COMPONENTS, LIVELINK TELEMATICS AND WORLD-CLASS AFTERCARE ALL COME AS STANDARD, WITH TAILORED SERVICE PACKAGES AVAILABLE TO SUIT.

Routine maintenance.

1 It's easy to get to the engine on a new JCB 457 with a large single-piece hood..

2 Accessing the diesel and DEF (Diesel Exhaust Fluid) tanks is also straightforward, via the lockable grille at the rear of the machine.

You can check washer fluid level, engine oil and coolant from inside the cab, with all other routine checks and grease points located at ground level. This makes life both easier and safer.

3 The standard widecore cooling package is a large, single-faced unit so you can be assured of quick, easy and safe cleaning.

4 Fold down rear access steps provide better access to service filters and fluid drain points.

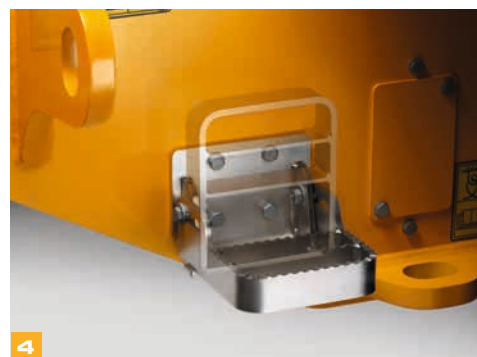

Less servicing, more service.

6 The CommandPlus cab relays machine condition with real-time alerts, safeguarding both the machine and the operator.

The intuitive CommandPlus help function provides the operator with meaningful descriptions of in-cab switch functions. Using the "?" button allows new or unfamiliar operators to quickly and easily understand them without having to refer to the operator's manual.

7 By using premium components: Cummins engine, ZF transmissions and axles, Rexroth pumps and Parker valve block, we've built in long service life as standard.

Full hydraulic dual circuit braking with multiple oil immersed discs gives the braking system a virtually maintenance-free lifespan.

8 A cyclonic engine fan scavenge filter provides four times the filtering capacity of a standard air filter. Its longer life system has fewer components and a higher level of efficiency, making for better engine protection.

9 Heating and ventilation filters are conveniently located behind an external access panel. The main fuse board and relays have been repositioned next to the door for easy access.

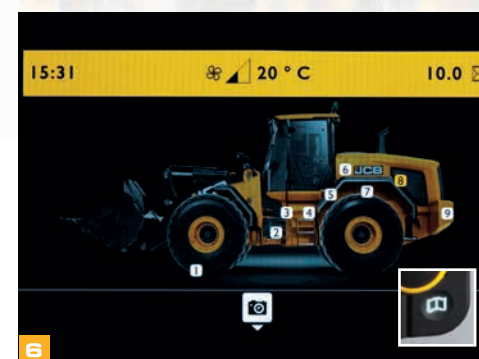
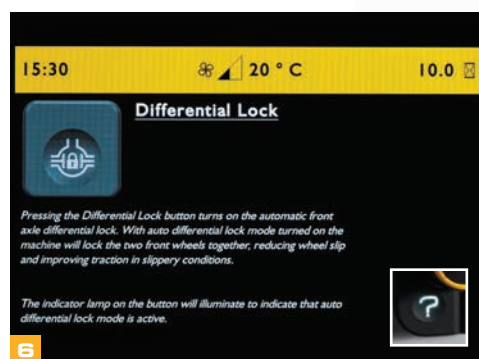

FULLY PROTECTED.

OPERATORS, BYSTANDERS AND YOUR FLEET ARE WELL PROTECTED AT ALL TIMES BY THE NEW JCB 457. GREAT VISIBILITY INSIDE AND OUT, NON-SLIP SURFACES AND EXCELLENT AIR FILTRATION ARE JUST THE BEGINNING.

Safely does it.

- 1 If you plan to use your wheeled loader for quarry work, it's worth specifying the dedicated quarry safety pack. This includes blue flashing reverse lights, a green operator presence beacon, a rear object detection system and hi-viz exterior chevrons.
- 2 Access steps are inclined and equally spaced, complemented by well positioned grab handles for three points of contact at all times.
- 3 On the new JCB 457, you'll find the rear-view mirrors mounted in front of the A-pillars for improved all-around visibility. Interior mirrors, heated exterior mirrors and hood mirrors all combine to offer excellent views to every corner of your machine.
- 4 Our rearward camera displays an unobstructed view from the back of the machine.
- 5 Superb visibility in dark conditions is guaranteed with JCB's optional LED lighting.



Roof mounted camera option provides additional visibility when large capacity attachments are fitted.



6 The new front fender flaps have been carefully designed and honed to keep forward spray to a minimum. This increases safety and decreases debris build-up.

7 The new 457's cab is isolator-mounted, compliant with ROPS/FOPS standards, and positively pressurized against dust. You can choose from fresh air and carbon recirculation filters as well.

8 Door hinges are mounted on the A-pillar; giving much better access via a larger and wider door aperture. It also means you can access the rear of your loader more safely.

Non-slip walkways and additional grab handle options allow for safe movement around the machine.



6



7



8



LIVELINK TELEMATICS.

LiveLink telematics helps you monitor and manage your machine fleet remotely anywhere in the world by radically improving the efficiency, productivity, safety and security of all your JCB and non JCB machine fleet.

MACHINE EFFICIENCY: Keep track of your machine's daily activity with regular performance reports which provide information about idle time, location, machine health, error codes for diagnostics, engine utilisation by power band, safety alerts, and fuel consumption. JCB LiveLink ensures machines are kept running for maximum uptime and return on investment.

MACHINE RELIABILITY: Accurate hours and service alerts improve maintenance planning to optimise machine productivity.

MACHINE SECURITY: LiveLink's real time geo-fencing alerts tell you when machines move out of predetermined zones. Curfew alerts inform you of unauthorised usage.



Track the location of any asset via Bluetooth connection.



An after market telematics solution which can be retrofitted to any machine.



COMPLETE CONTROL FOR YOUR FLEET.

LiveLink Fleet enables you to track every aspect of your equipment to maximise efficiency and machine uptime.

GUESS LESS, KNOW MORE: Equipment issues and service reminders are logged as soon as they occur, helping you to react quickly.

YOUR EYES ON THE GROUND: Integrate LiveLink Fleet with the JCB Operator mobile app and data from your operators' daily equipment checks feed instantly into your dashboard.

TOTAL PEACE OF MIND: Operator safety alerts help to ensure machines are being used efficiently and safely.

SMARTER TOOLS. SMARTER DECISIONS: From hours worked to fuel wastage, access custom analytics on your fleet to make smarter decisions, quicker.

EFFORTLESS MEETS PAPERLESS: Access certificates, warranty information, quick start machine guides and manuals.

The JCB Operator app

THEY SPOT IT, YOU KNOW IT.

The JCB Operator app gives you faster, clearer and more accurate information about your fleet, direct from the people using your equipment each day.

STAY IN TOUCH: Get regular checks on your machine with visibility in the LiveLink Fleet portal.

TAILOR YOUR CHECKS: Customise your checklists to suit any application, customer or site.

UPLOAD TO KEEP UPDATED: Upload useful information with photos and comments.

FULLY COMPATIBLE: The JCB Operator app works with non telemetry related machines and assets.

ACCESS ALL INFORMATION: Get access to documentation such as quick start guides.

*The individual features of LiveLink Telematics, LiveLink Fleet and Operator App vary per region, engine and machine type.

FULLY SUPPORTED.

JCB'S WORLDWIDE CUSTOMER SUPPORT IS FIRST CLASS. WHATEVER YOU NEED AND WHEREVER YOU ARE, WE'LL BE AVAILABLE QUICKLY AND EFFICIENTLY TO HELP MAKE SURE YOUR MACHINERY IS PERFORMING TO ITS FULL POTENTIAL.

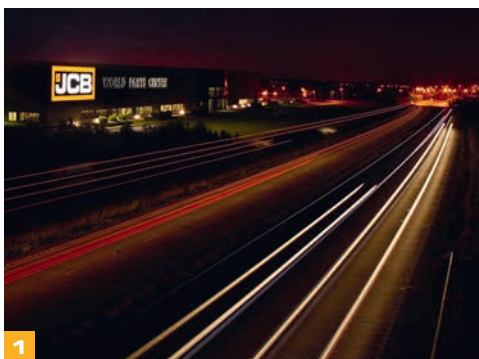

1

1 Our Technical Support Service provides instant access to factory expertise, day or night, while our Finance and Insurance teams are always on hand to provide fast, flexible, competitive quotes.

2 The global network of JCB Parts Centres is another model of efficiency; with 18 regional bases, we can deliver around 95% of all parts anywhere in the world within 24 hours. Our genuine JCB parts are designed to work in perfect harmony with your machine for optimum performance and productivity.



2

3 JCB offers comprehensive extended warranties as well as service-only or repair and maintenance contracts. Irrespective of what you opt for, our Maintenance teams around the world charge competitive pay rates, and offer non-obligation quotations as well as fast, efficient insurance repair work.



3

Note: JCB LIVELINK and JCB extended warranty packages may not be available in your region, so please check with your local dealer.

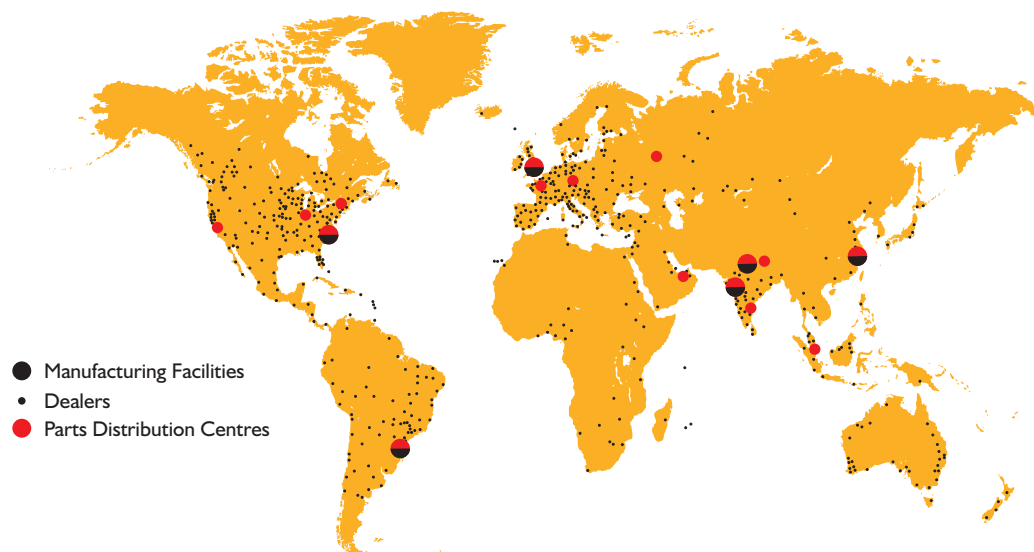

STATIC DIMENSIONS

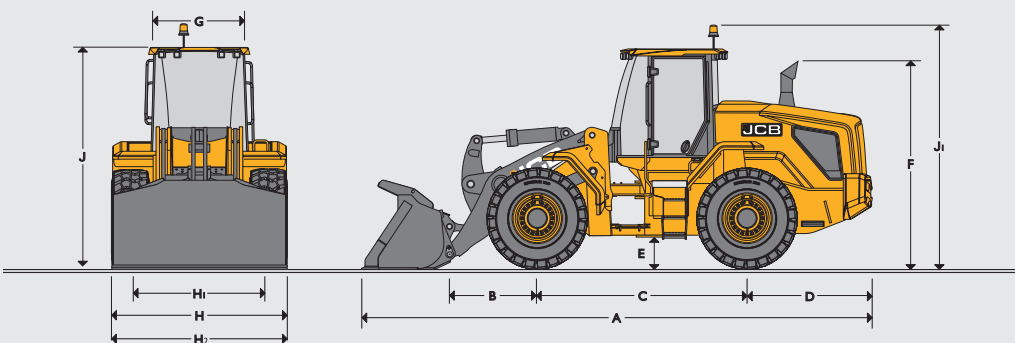

		457 HT	457 HT HL	457 HT SHL	457 ZX
A	Overall length	ft-in (mm) 27' 11" (8508)	29' 4" (8950)	31' 0" (9451)	26' 1" (7961)
B	Axle to pivot pin	ft-in (mm) 5' 2" (1577)	6' 7" (2018)	8' 1" (2727)	5' 4" (1622)
C	Wheel base	ft-in (mm) 10' 10" (3300)	10' 10" (3300)	10' 10" (3300)	10' 10" (3300)
D	Axle to counterweight face	ft-in (mm) 6' 6" (1971)	6' 6" (1971)	6' 6" (1971)	6' 6" (1971)
E	Minimum ground clearance	ft-in (mm) 1' 7" (487)	1' 7" (487)	1' 7" (487)	1' 7" (473)
F	Height over exhaust	ft-in (mm) 10' 6" (3197)	10' 6" (3197)	10' 6" (3197)	10' 7" (3224)
G	Width over cab	ft-in (mm) 5' 3" (1600)	5' 3" (1600)	5' 3" (1600)	4' 9" (1446)
H	Max width over tires	ft-in (mm) 8' 10" (2698)	8' 10" (2698)	8' 10" (2698)	8' 10" (2699)
H1	Wheel track	ft-in (mm) 6' 11" (2100)	6' 11" (2100)	6' 11" (2100)	6' 11" (2100)
J	Height over cab	ft-in (mm) 11' 3" (3427)	11' 3" (3427)	11' 3" (3427)	11' 3" (3423)
	Pin height (maximum)	ft-in (mm) 14' 2" (4307)	15' 7" (4750)	17' 4" (5273)	13' 6" (4110)
	Front axle weight	lbs (kg) 18175 (8244)	19522 (8855)	21608 (9801)	19809 (8985)
	Rear axle weight	lbs (kg) 26449 (11997)	25787 (11697)	24559 (11140)	24282 (11014)
	Total weight	lbs (kg) 44622 (20240)	45309 (20552)	46167 (20941)	44090 (19999)

Data based on machine equipped with direct mounted 3.5 m³ bucket with toe plate and Michelin 23.5 R25 XHA2 (L3) tires. HT machines include Heavy Duty counterweight.

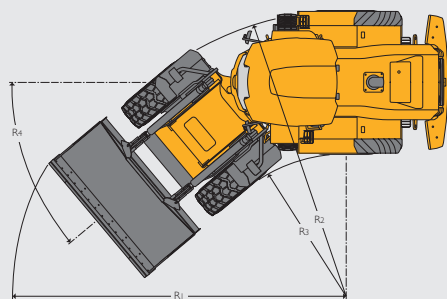

		457 HT	457 HT HL	457 HT SHL	457 ZX
R1	Maximum turn radius over shovel	mm 6527	6822	6933	6507
R2	Maximum turn radius over tire	mm 5883	5883	5883	5883
R3	Inside turn radius	mm 3183	3183	3183	3183
R4	Articulation angle	degrees +/-40	+/-40	+/-40	+/-40

TRANSMISSION

Type	5 Speed Non LUC Converter (ZF)				5 Speed LUC Converter (ZF) *Assumes LUC Engaged			
	ZF 5WG210				ZF 5WG210 with lock-up			
Gear	Forward Dynamic Mode	Reverse Dynamic Mode	Forward Comfort Mode	Reverse Comfort Mode	Forward Dynamic Mode	Reverse Dynamic Mode	Forward Comfort Mode	Reverse Comfort Mode
1	mph (kph) 4 (6.37)	4.2 (6.74)	3.4 (5.44)	3.6 (5.75)	3.7 (6.02)	4 (6.37)	3.4 (5.4)	3.5 (5.7)
2	mph (kph) 7.3 (11.67)	7.6 (12.3)	6.2 (10.02)	6.6 (10.56)	7 (11.29)	7.4 (11.9)	6.3 (10.2)	6.7 (10.75)
3	mph (kph) 11 (17.77)	17.5 (28.17)	9.5 (15.21)	14.5 (23.36)	10.7 (17.3)	17.5 (28.16)	9.7 (15.62)	15.8 (25.4)
4	mph (kph) 16.7 (26.9)		13.9 (22.37)		16.6 (26.75)		15 (24.13)	
5	mph (kph) 24 (38.68)		19.3 (31.09)		25.3 (40.7)		22.6 (36.38)	

ENGINE

Manufacturer	Cummins
Model	B Series
Capacity	in ³ (liters) 409 (6.7)
Aspiration	Turbo Charged
Cylinders	6
Max gross power to SAE J1995/ISO 14396	kW (hp) @ 1900 rpm 210 (282)
Rated gross power to SAE J1995/ISO 14396	kW (hp) @ 2200 rpm 194 (260)
Nett power to ISO 9249	kW (hp) @ 2200 rpm 191 (257)
Max torque	lb-ft (Nm) @ 1300 rpm 996 (1350)
Valves per cylinder	4
Air cleaner	Cyclonic pre filter with engine fan scavenge system
Fan drive type	Hydraulically driven cooling fan
Emissions	EU Stage V, US EPA Tier 4F

AXLES

Type	Open differential	Limited slip differential	Open differential with auto-locking front
Make and model	ZF MT-L 3095 MK 2 (front and rear)	ZF MT-L 3095 MK 2 (front and rear)	ZF MT-L 3095 MK 2 (front and rear)
Overall axle ratio	23.334:1	23.334:1	23.334:1
Rear axle oscillation	+/-12.5°	+/-12.5°	+/-12.5°

All available with open differential, limited slip differential, open differential with auto-locking front.

ELECTRICAL SYSTEM

System voltage	Amps	24
Alternator output	Amps	100
Battery capacity	Amp hour	2 x 110

HYDRAULICS

Pump type	Variable displacement
Pump 1 maximum flow	l/min 153
Pump 1 maximum pressure	bar 220
Pump 2 maximum flow	l/min 153
Pump 2 maximum pressure	bar 170

Hydraulic cycle times at full engine RPM

Arms raise (full bucket)	Seconds	5.8
Shovel dump (full bucket)	Seconds	1.2
Arms lower (empty bucket)	Seconds	4.1
Total cycle	Seconds	11.1

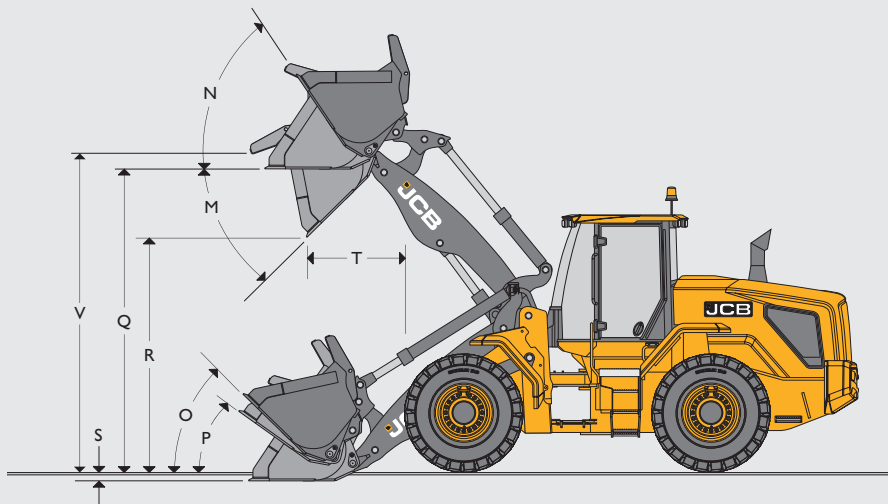

TIRE SIZE

Tire size	Manufacturer	Type	Rating	Op weight kg	457HT std arms			Dimensions	
					STL kg	FTTL kg	Vertical	Width	
23.5R25 (Radial)	Michelin	XTLA	L2	-12	-8	-6	-2	-3	
650/65R25 (Radial)	Michelin	XLD	L3	-92	-58	-49	-56	35	
23.5R25 (Radial)	Goodyear	TL-3A+	L3	324	204	174	19	0	
23.5R25 (Radial)	Goodyear	RT-3B	L3	176	111	95	10	0	
23.5-25 (Crossply)	Goodyear	HRL-3A (20ply)	L3	-100	-63	-54	15	0	
23.5-25 (Crossply)	JCB	SITEMASTER (24 Ply)	L3	-92	-58	-49	6	1	
23.5R25 (Radial)	JCB	EARTHMOVER	L3	160	101	86	1	6	
23.5R25 (Radial)	Michelin	XLDD2A	L5	548	344	295	27	13	
23.5R25 (Radial)	Michelin	XMINE D2	L5	828	520	445	37	38	
23.5R25 (Radial)	Goodyear	RL-5K	L5	792	498	426	9	24	
23.5R25 (Solid cushion)	SG Revolution	S2 C2 DWL	-	3124	1964	1680	51	-24	

*Heavy duty counterweight replaced by standard counterweight when solid tires are fitted.

LOADER DIMENSIONS

Model		457 HT												
		Direct						Quickhitch						
Shovel mounting		Tipped teeth		Reversible toeplate		Tipped teeth and toeplate segments		Tipped teeth		Reversible toeplate		Tipped teeth and toeplate segments		
Shovel equipment		Tipped teeth		Reversible toeplate		Tipped teeth and toeplate segments		Tipped teeth		Reversible toeplate		Tipped teeth and toeplate segments		
Shovel capacity (SAE heaped 100%)	yd ³ (m ³)	3.1	3.3	3.3	3.5	3.3	3.5	3.1	3.3	3.3	3.5	3.3	3.5	
Shovel capacity (struck)	yd ³ (m ³)	2.497	2.687	2.648	2.844	2.648	2.844	2.497	2.687	2.648	2.844	2.648	2.844	
Shovel width	ft-in (mm)	2837	2837	2800	2800	2837	2837	2837	2837	2800	2800	2837	2837	
Shovel weight	lbs (kg)	1519	1565	1629	1675	1667	1713	1426	1417	1536	1581	1574	1619	
Maximum material density *	lbs/yd ³ (kg/m ³)	2118	1975	1972	1846	1963	1837	1996	1863	1858	1740	1853	1732	
Tipping load straight *	lbs (kg)	15609	15506	15480	15387	15432	15327	14760	14670	14643	14552	14609	14492	
Tipping load full turn *	lbs (kg)	13130	13035	13014	12919	12956	12860	12377	12295	12263	12180	12229	12122	
Payload *	lbs (kg)	6565	6518	6507	6460	6478	6430	6189	6148	6131	6090	6115	6061	
Maximum breakout force	lbf (kN)	161	153	150	143	150	143	144	138	135	130	135	130	
M	Dump angle maximum	degrees	45	45	45	45	45	45	45	45	45	45	45	
N	Roll back angle full height	degrees	57	57	57	57	57	57	57	57	57	57	57	
O	Roll back at carry	degrees	52	52	52	52	52	52	52	52	52	52	52	
P	Roll back at ground level	degrees	46	46	46	46	46	46	46	46	46	46	46	
Q	Load over height	ft-in (mm)	3999	3999	4031	4031	3999	3999	3999	4031	4031	3999	3999	
R	Dump height (45 deg dump)	ft-in (mm)	2923	2881	3072	3030	2923	2881	2817	2775	2966	2924	2817	2772
S	Dig depth	ft-in (mm)	120	120	88	88	120	120	120	120	88	88	120	120
T	Reach at dump height	ft-in (mm)	1326	1368	1216	1258	1326	1368	1432	1474	1322	1364	1432	1474
V	Pin height	ft-in (mm)	4307	4307	4307	4307	4307	4307	4307	4307	4307	4307	4307	
	Reach maximum (45 deg dump) horizontal arm	ft-in (mm)	2303	2345	2193	2232	2303	2345	2409	2451	2299	2438	2409	2451
	Operating weight	lbs (kg)	20050	20096	20146	20192	20194	20240	20337	20382	20433	20478	20461	20526

*Assumes machine is fitted with Michelin 23.5R25 XHA2 (L3) tires.

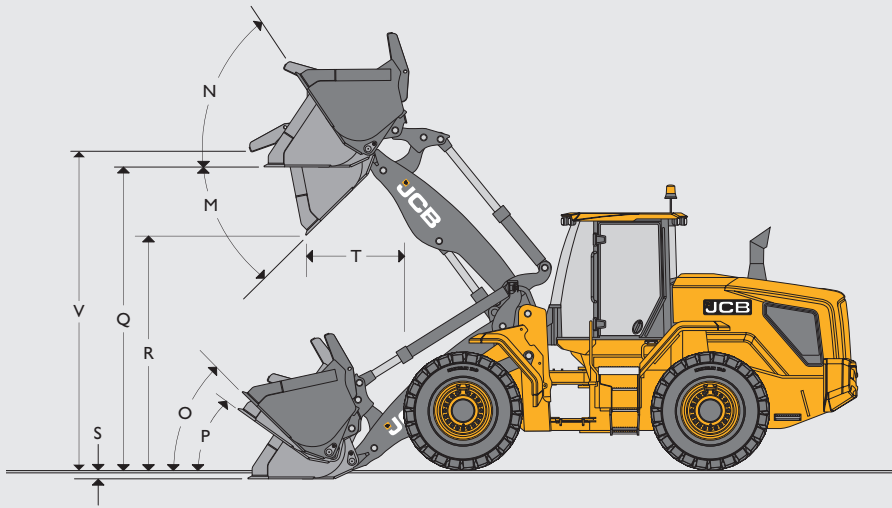

TIRE SIZE					457HT HL arms		Dimensions	
Tire size	Manufacturer	Type	Rating	Op weight kg	STL kg	FTTL kg	Vertical	Width
23.5R25 (Radial)	Michelin	XTLA	L2	-12	-7	-6	-2	-3
650/65R25 (Radial)	Michelin	XLD	L3	-92	-51	-43	-56	35
23.5R25 (Radial)	Goodyear	TL-3A+	L3	324	178	152	19	0
23.5R25 (Radial)	Goodyear	RT-3B	L3	176	97	83	10	0
23.5-25 (Crossply)	Goodyear	HRL-3A (20ply)	L3	-100	-55	-47	15	0
23.5-25 (Crossply)	JCB	SITEMASTER (24 Ply)	L3	-92	-51	-43	6	1
23.5R25 (Radial)	JCB	EARTHMOVER	L3	160	88	75	1	6
23.5R25 (Radial)	Michelin	XLDD2A	L5	548	301	257	27	13
23.5R25 (Radial)	Michelin	XMINE D2	L5	828	455	389	37	38
23.5R25 (Radial)	Goodyear	RL-5K	L5	792	435	372	9	24
23.5R25 (Solid cushion)	SG Revolution	S2 C2 DWL	-	3124	1715	1467	51	-24

*Heavy duty counterweight replaced by standard counterweight when solid tires are fitted.

LOADER DIMENSIONS

Model	457HT HL													
	Direct							Quickhitch						
Shovel mounting														
Shovel equipment	Tipped teeth			Reversible toeplate		Tipped teeth and toeplate segments		Tipped teeth			Reversible toeplate		Tipped teeth and toeplate segments	
Shovel capacity (SAE heaped 100%)	yd ³ (m ³)	3.5 (2.8)	4.1 (3.1)	4.3 (3.3)	4.3 (3.3)	4.6 (3.5)	4.3 (3.3)	4.6 (3.5)	4.1 (3.1)	4.3 (3.3)	4.3 (3.3)	4.6 (3.5)	4.3 (3.3)	3.3 (3.5)
Shovel capacity (struck)	yd ³ (m ³)	2.844 (2.21)	3.3 (2.497)	3.5 (2.687)	3.5 (2.648)	3.7 (2.844)	3.5 (2.648)	3.7 (2.844)	3.3 (2.497)	3.5 (2.687)	3.5 (2.648)	3.7 (2.844)	3.5 (2.648)	2.648 (2.844)
Shovel width	ft-in (mm)	9' 4" (2837)	9' 4" (2837)	9' 4" (2837)	9' 2" (2800)	9' 2" (2800)	9' 4" (2837)	9' 4" (2837)	9' 4" (2837)	9' 4" (2837)	9' 2" (2800)	9' 2" (2800)	9' 4" (2837)	9' 4" (2837)
Shovel weight	lbs (kg)	3190 (1447)	3349 (1519)	3450 (1565)	3591 (1629)	3693 (1675)	3675 (1667)	3777 (1713)	3144 (1426)	3124 (1417)	3386 (1536)	3486 (1581)	3470 (1574)	3569 (1619)
Maximum material density *	lbs/yd ³ (kg/m ³)	3334 (1978)	3019 (1791)	2815 (1670)	2808 (1666)	2628 (1559)	2793 (1657)	2614 (1551)	2849 (1690)	2658 (1577)	2648 (1571)	2479 (1471)	2640 (1566)	2466 (1463)
Tipping load straight *	lbs (kg)	29064 (13183)	29220 (13254)	29024 (13165)	28967 (13139)	28770 (13050)	28839 (13081)	28640 (12991)	27672 (12552)	27500 (12474)	27423 (12439)	27249 (12360)	27348 (12405)	27121 (12302)
Tipping load full turn *	lbs (kg)	24418 (11076)	24482 (11105)	24304 (11024)	24238 (10994)	24055 (10911)	24112 (10937)	23929 (10854)	23100 (10478)	22944 (10407)	22855 (10367)	22697 (10295)	22785 (10335)	22571 (10238)
Payload *	lbs (kg)	12209 (5538)	12242 (5553)	12152 (5512)	12119 (5497)	12028 (5456)	12055 (5468)	11964 (5427)	11550 (5239)	11471 (5203)	11429 (5184)	11349 (5148)	11391 (5167)	11285 (5119)
Maximum breakout force	lbf (kN)	39566 (176)	36644 (163)	34845 (155)	33946 (151)	34621 (154)	33946 (151)	34621 (154)	32822 (146)	31473 (140)	30349 (135)	29000 (129)	30349 (135)	29000 (129)
M Dump angle maximum	degrees	45	45	45	45	45	45	45	45	45	45	45	45	45
N Roll back angle full height	degrees	56	56	56	56	56	56	56	56	56	56	56	56	56
O Roll back at carry	degrees	48	48	48	48	48	48	48	48	48	48	48	48	48
P Roll back at ground level	degrees	43	43	43	43	43	43	43	43	43	43	43	43	43
Q Load over height	ft-in (mm)	14' 7" (4446)	14' 7" (4443)	14' 7" (4443)	14' 7" (4447)	14' 7" (4447)	14' 5" (4383)	14' 7" (4443)	14' 7" (4443)	14' 7" (4443)	14' 7" (4447)	14' 7" (4447)	14' 7" (4443)	14' 7" (4443)
R Dump height (45 deg dump)	ft-in (mm)	10' 9" (3264)	10' 11" (3328)	11' 1" (3370)	11' 5" (3476)	11' 3" (3435)	10' 11" (3328)	11' 1" (3370)	10' 7" (3222)	10' 5" (3180)	11' 1" (3371)	10' 11" (3329)	10' 7" (3222)	10' 5" (3180)
S Dig depth	ft-in (mm)	0' 5" (120)	0' 5" (120)	0' 5" (120)	0' 5" (120)	0' 5" (120)	0' 6" (152)	0' 6" (152)	0' 5" (120)	0' 5" (120)	0' 5" (120)	0' 5" (120)	0' 6" (152)	0' 6" (152)
T Reach at dump height	ft-in (mm)	4' 5" (1350)	4' 3" (1286)	4' 5" (1350)	4' 3" (1286)	4' 1" (1244)	4' 7" (1396)	4' 5" (1354)	4' 3" (1286)	4' 1" (1244)	3' 10" (1180)	3' 9" (1138)	4' 3" (1290)	4' 1" (1248)
V Pin height	ft-in (mm)	15' 7" (4750)	15' 7" (4750)	15' 7" (4750)	15' 7" (4750)	15' 7" (4750)	15' 7" (4750)	15' 7" (4750)	15' 7" (4750)	15' 7" (4750)	15' 7" (4750)	15' 7" (4750)	15' 7" (4750)	15' 7" (4750)
Reach maximum (45 deg dump) horizontal arm	ft-in (mm)	8' 6" (2603)	8' 9" (2667)	8' 11" (2709)	8' 5" (2557)	8' 6" (2599)	8' 9" (2667)	8' 11" (2709)	9' 1" (2773)	9' 3" (2814)	8' 9" (2663)	8' 10" (2705)	9' 1" (2773)	9' 3" (2814)
Operating weight	lbs (kg)	44335 (20110)	44891 (20362)	44992 (20408)	45102 (20458)	45204 (20504)	45208 (20506)	45309 (20552)	45523 (20649)	45622 (20694)	45735 (20745)	45834 (20790)	45797 (20773)	45940 (20838)

*Assumes machine is fitted with Michelin 23.5R25 XHA2 (L3) tires.

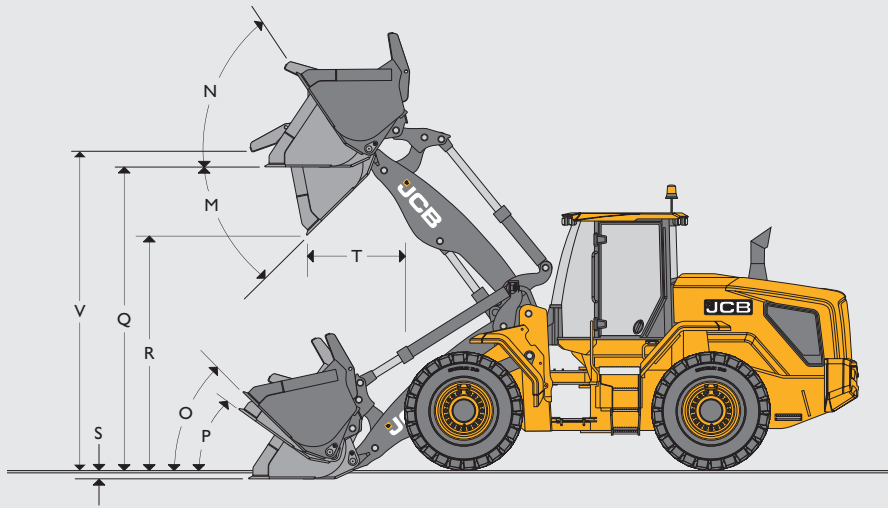

TIRE SIZE					457HT SHL arms			Dimensions	
Tire size	Manufacturer	Type	Rating	Op weight kg	STL kg	FTTL kg	Vertical	Width	
23.5R25 (Radial)	Michelin	XTLA	L2	-12	-6	-5	-2	-3	
650/65R25 (Radial)	Michelin	XLD	L3	-92	-44	-38	-56	35	
23.5R25 (Radial)	Goodyear	TL-3A+	L3	324	155	132	19	0	
23.5R25 (Radial)	Goodyear	RT-3B	L3	176	84	72	10	0	
23.5-25 (Crossply)	Goodyear	HRL-3A (20ply)	L3	-100	-48	-41	15	0	
23.5-25 (Crossply)	JCB	SITEMASTER (24 Ply)	L3	-92	-44	-38	6	1	
23.5R25 (Radial)	JCB	EARTHMOVER	L3	160	76	65	1	6	
23.5R25 (Radial)	Michelin	XLDD2A	L5	548	261	224	27	13	
23.5R25 (Radial)	Michelin	XMINE D2	L5	828	395	338	37	38	
23.5R25 (Radial)	Goodyear	RL-5K	L5	792	378	323	9	24	
23.5R25 (Solid cushion)	SG Revolution	S2 C2 DWL	-	3124	1490	1275	51	-24	

*Heavy duty counterweight replaced by standard counterweight when solid tires are fitted.

LOADER DIMENSIONS

Model	457 HT SHL																	
	Direct							Quickhitch										
Shovel mounting	Tipped teeth							Reversible toeplate		Tipped teeth and toeplate segments		Tipped teeth		Reversible toeplate		Tipped teeth and toeplate segments		
Shovel equipment	Tipped teeth		Reversible toeplate		Tipped teeth and toeplate segments		Tipped teeth		Reversible toeplate		Tipped teeth and toeplate segments		Tipped teeth		Reversible toeplate		Tipped teeth and toeplate segments	
Shovel capacity (SAE heaped 100%)	yd ³ (m ³)	3.5 (2.8)	4.1 (3.1)	4.3 (3.3)	4.3 (3.3)	4.6 (3.5)	4.3 (3.3)	4.6 (3.5)	4.1 (3.1)	4.3 (3.3)	4.3 (3.3)	4.6 (3.5)	4.3 (3.3)	4.6 (3.5)	4.3 (3.3)	4.6 (3.5)		
Shovel capacity (struck)	yd ³ (m ³)	2.844 (2.21)	3.3 (2.497)	3.5 (2.687)	3.5 (2.648)	3.7 (2.844)	3.5 (2.648)	3.7 (2.844)	3.3 (2.497)	3.5 (2.687)	3.5 (2.648)	3.7 (2.844)	3.3 (2.648)	3.5 (2.844)	3.3 (2.648)	3.5 (2.844)		
Shovel width	ft-in (mm)	9' 4" (2837)	9' 4" (2837)	9' 4" (2837)	9' 2" (2800)	9' 2" (2800)	9' 4" (2837)	9' 4" (2837)	9' 4" (2837)	9' 4" (2837)	9' 2" (2800)	9' 2" (2800)	9' 4" (2837)	9' 4" (2837)				
Shovel weight	lbs (kg)	3190 (1447)	3349 (1519)	3450 (1565)	3591 (1629)	3693 (1675)	3675 (1667)	3777 (1713)	3144 (1426)	3124 (1417)	3386 (1536)	3486 (1581)	3470 (1574)	3569 (1619)				
Maximum material density *	lbs/ycd ³ (kg/m ³)	2790 (1655)	2474 (1468)	2308 (1369)	2297 (1363)	2149 (1275)	2284 (1355)	2136 (1267)	2333 (1384)	2174 (1290)	2164 (1284)	2024 (1201)	2156 (1279)	2011 (1193)				
Tipping load straight *	lbs (kg)	24493 (11110)	24143 (10951)	23973 (10874)	23898 (10840)	23726 (10762)	23772 (10783)	23600 (10705)	22862 (10370)	22712 (10302)	22617 (10259)	22467 (10191)	22547 (10227)	22342 (10134)				
Tipping load full turn *	lbs (kg)	20437 (9270)	20071 (9104)	19912 (9032)	19831 (8995)	19672 (8923)	19709 (8940)	19548 (8867)	18916 (8580)	18777 (8517)	18678 (8472)	18536 (8408)	18607 (8440)	18415 (8353)				
Payload *	lbs (kg)	10218 (4635)	10035 (4552)	9956 (4516)	9916 (4498)	9835 (4461)	9855 (4470)	9775 (4434)	9458 (4290)	9387 (4258)	9339 (4236)	9268 (4204)	9304 (4220)	9209 (4177)				
Maximum breakout force	lbf (kN)	39342 (175)	36644 (163)	34845 (155)	34171 (152)	32597 (145)	34171 (152)	32597 (145)	32822 (146)	31473 (140)	30799 (137)	29675 (132)	30799 (137)	29675 (132)				
M	Dump angle maximum	degrees	45	45	45	45	45	45	45	45	45	45	45	45				
N	Roll back angle full height	degrees	58	58	58	58	58	58	58	58	58	58	58	58				
O	Roll back at carry	degrees	54	54	54	54	54	54	54	54	54	54	54	54				
P	Roll back at ground level	degrees	46	46	46	46	46	46	46	46	46	46	46	46				
Q	Load over height	ft-in (mm)	16' 3" (4962)	16' 3" (4965)	16' 3" (4965)	16' 5" (4997)	16' 5" (4997)	16' 3" (4965)	16' 3" (4965)	16' 3" (4965)	16' 5" (4997)	16' 5" (4997)	16' 3" (4965)	16' 3" (4965)				
R	Dump height (45 deg dump)	ft-in (mm)	12' 12" (3953)	12' 9" (3889)	12' 7" (3847)	13' 3" (4037)	13' 1" (3996)	12' 9" (3889)	12' 7" (3847)	12' 5" (3783)	12' 3" (3741)	12' 11" (3932)	12' 9" (3890)	12' 5" (3783)	12' 3" (3741)			
S	Dig depth	ft-in (mm)	0' 5" (120)	0' 5" (120)	0' 5" (120)	0' 3" (88)	0' 3" (88)	0' 5" (120)	0' 5" (120)	0' 5" (120)	0' 5" (120)	0' 3" (88)	0' 3" (88)	0' 5" (120)	0' 5" (120)			
T	Reach at dump height	ft-in (mm)	4' 4" (1319)	4' 6" (1383)	4' 8" (1425)	4' 2" (1273)	4' 4" (1315)	4' 6" (1383)	4' 8" (1425)	4' 11" (1489)	5' 0" (1531)	4' 6" (1379)	4' 8" (1421)	4' 11" (1489)	5' 0" (1531)			
V	Pin height	ft-in (mm)	17' 4" (5273)	17' 4" (5273)	17' 4" (5273)	17' 4" (5273)	17' 4" (5273)	17' 4" (5273)	17' 4" (5273)	17' 4" (5273)	17' 4" (5273)	17' 4" (5273)	17' 4" (5273)	17' 4" (5273)				
	Reach maximum (45 deg dump) horizontal arm	ft-in (mm)	9' 12" (3038)	10' 2" (3102)	10' 4" (3144)	9' 10" (2992)	9' 11" (3034)	10' 2" (3102)	10' 4" (3144)	10' 6" (3208)	10' 8" (3249)	10' 2" (3098)	10' 4" (3140)	10' 6" (3208)	10' 8" (3249)			
	Operating weight	lbs (kg)	45193 (20499)	45748 (20751)	45850 (20797)	45960 (20847)	46061 (20893)	46066 (20895)	46167 (20941)	46381 (21038)	46480 (21083)	46592 (21134)	46692 (21179)	46654 (21162)	46798 (21227)			

*Assumes machine is fitted with Michelin 23.5R25 XHA2 (L3) tires.

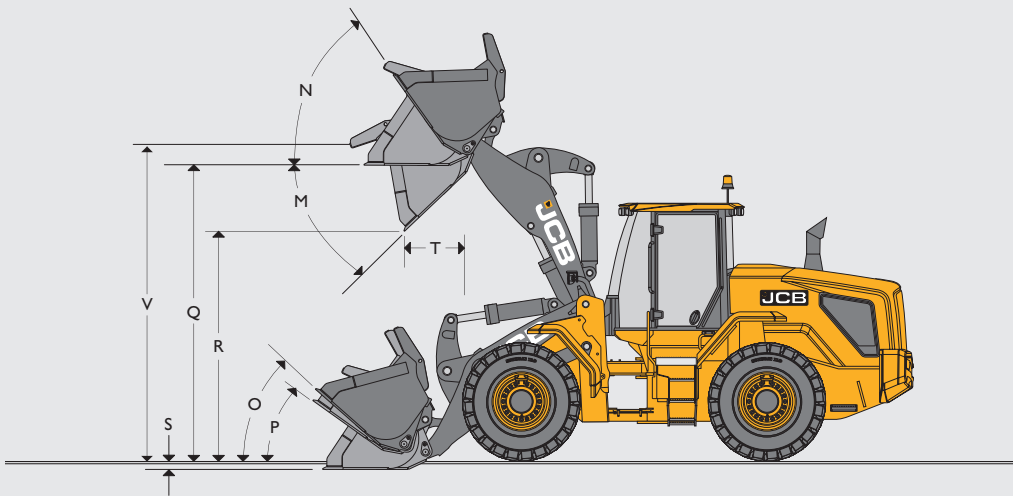

TIRE SIZE

Tire size	Manufacturer	Type	Rating	Op weight kg	457ZX std arms		Dimensions		
					STL kg	FTTL kg	Vertical mm	Width mm	
23.5R25 (Radial)	Michelin	XTLA	L2	-12	-9	-8	-2	-3	
650/65R25 (Radial)	Michelin	XLD	L3	-92	-69	-59	-56	35	
23.5R25 (Radial)	Goodyear	TL-3A+	L3	324	243	208	19	0	
23.5R25 (Radial)	Goodyear	RT-3B	L3	176	132	113	10	0	
23.5-25 (Crossply)	Goodyear	HRL-3A (20ply)	L3	-100	-75	-64	15	0	
23.5-25 (Crossply)	JCB	SITEMASTER (24 Ply)	L3	-92	-69	-59	6	1	
23.5R25 (Radial)	JCB	EARTHMOVER	L3	160	120	103	1	6	
23.5R25 (Radial)	Michelin	XLDD2A	L5	548	412	352	27	13	
23.5R25 (Radial)	Michelin	XMINE D2	L5	828	622	532	37	38	
23.5R25 (Radial)	Goodyear	RL-5K	L5	792	595	509	9	24	
23.5R25 (Solid cushion)	SG Revolution	S2 C2 DWL	-	3124	2347	2008	51	-24	
Heavy Duty Counterweight				-	774	1752	1566	51	-24

*Heavy duty counterweight not available with L5 & solid tires

LOADER DIMENSIONS

Model	457 ZX												
		Direct						Quickhitch					
		General purpose			General purpose			General purpose			General purpose		
	Tipped teeth		Reversible toeplate		Tipped teeth and toeplate segments		Tipped teeth		Reversible toeplate		Tipped teeth and toeplate segments		
Shovel mounting													
Shovel type													
Shovel equipment													
Shovel capacity (SAE heaped)	yd ³ (m ³)	3.1	3.3	3.3	3.5	3.3	3.5	3.1	3.3	3.3	3.5	3.3	3.5
Shovel capacity (struck)	yd ³ (m ³)	3	3	3	3	3	3	2	3	3	3	3	3
Shovel width	ft-in (mm)	2837	2837	2800	2800	2837	2837	2837	2837	2800	2800	2837	2837
Shovel weight	lbs (kg)	1613	1656	1723	1766	1761	1804	1426	1471	1536	1581	1574	1619
Maximum material density *	lbs/yd ³ (kg/m ³)	2217	2068	2064	1933	2055	1924	2122	1984	1975	1854	1970	1845
Tipping load straight *	lbs (kg)	16494	16390	16364	16269	16313	16208	15846	15780	15725	15658	15690	15596
Tipping load full turn *	lbs (kg)	13743	13648	13626	13530	13566	13470	13156	13094	13037	12975	13002	12915
Payload *	lbs (kg)	6872	6824	6813	6765	6783	6735	6578	6547	6519	6488	6501	6457
Maximum breakout force	lbf (kN)	172	165	161	154	161	154	153	147	143	137	143	137
M Dump angle maximum	degrees	45	45	45	45	45	45	45	45	45	45	45	45
N Roll back angle full height	degrees	67	67	67	67	67	67	67	67	67	67	67	67
O Roll back at carry	degrees	45	45	45	45	45	45	45	45	45	45	45	45
P Roll back at ground level	degrees	39	39	39	39	39	39	39	39	39	39	39	39
Q Load over height	ft-in (mm)	3802	3802	3834	3834	3802	3802	3802	3802	3834	3834	3802	3802
R Dump height (45 deg dump)	ft-in (mm)	2740	2698	2890	2848	2740	2698	2620	2578	2770	2728	2620	2578
S Dig depth	ft-in (mm)	120	120	88	88	120	120	120	120	88	88	120	120
T Reach at dump height	ft-in (mm)	1301	1343	1191	1233	1301	1343	1421	1463	1311	1353	1421	1463
V Pin height	ft-in (mm)	4110	4110	4110	4110	4110	4110	4110	4110	4110	4110	4110	4110
Reach maximum (45 deg dump) horizontal arm	ft-in (mm)	2140	2182	2029	2071	2140	2182	2260	2302	2149	2191	2260	2302
Operating weight	lbs (kg)	19811	19854	19907	19950	19956	19999	20170	20215	20266	20311	20295	20360

*Assumes machine is fitted with Michelin 23.5R25 XHA2 (L3) tires.

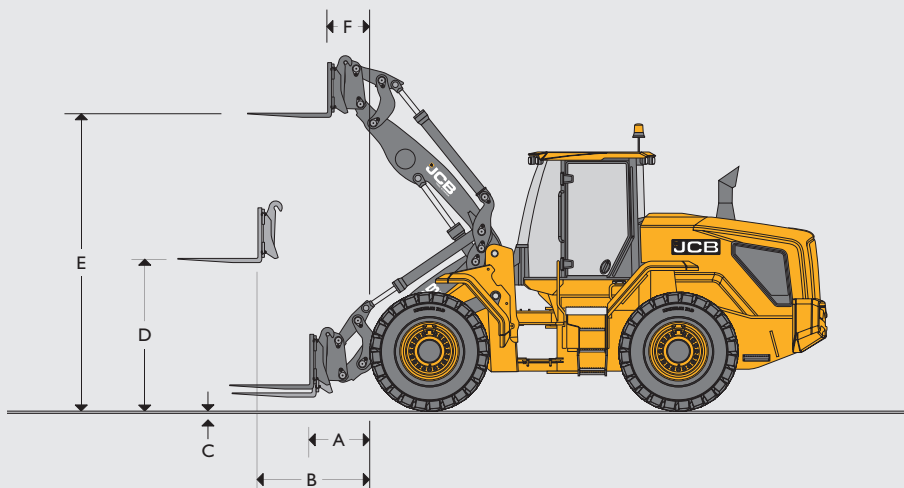

LOADER DIMENSIONS WITH FORKS

		457 HT	457 HT HL	457 HT SHL	457 ZX
Fork carriage width	ft-in (mm)	4' 11" (1500)	4' 11" (1500)	4' 11" (1500)	4' 11" (1500)
Length of tines	ft-in (mm)	4' 0" (1220)	4' 0" (1220)	4' 0" (1220)	4' 0" (1220)
A Reach at ground level	ft-in (mm)	3' 11" (1198)	5' 5" (1649)	7' 1" (2158)	3' 3" (1003)
B Reach at arms horizontal	ft-in (mm)	6' 1" (1847)	7' 3" (2213)	8' 8" (2647)	5' 7" (1697)
C Top of tine above ground with arms down	ft-in (mm)	0' 1" (28.5)	0' 1" (28.5)	0' 1" (28.5)	0' 1" (28.5)
D Arms, horizontal height	ft-in (mm)	6' 4" (1935)	6' 4" (1935)	6' 4" (1935)	6' 4" (1935)
E Arms, maximum height	ft-in (mm)	13' 7" (4143)	15' 1" (4598)	16' 9" (5109)	16' 9" (5109)
F Reach at maximum height	ft-in (mm)	2' 10" (875)	2' 12" (902.5)	3' 1" (933.5)	3' 1" (933.5)
Tipping load straight	lbs (kg)	40005 (18146)	29487 (13375)	21266 (9646)	33598 (15240)
Tipping load full turn (40°)	lbs (kg)	34163 (15496)	24967 (11325)	17915 (8126)	28270 (12823)
Payload*	lbs (kg)	17637 (8000)	17637 (8000)	14330 (6500)	17637 (8000)
Attachment weight	lbs (kg)	1345 (610)	1345 (610)	1345 (610)	1345 (610)
Operating weight(includes 80Kg operator and full fuel and Urea tanks)	lbs (kg)	43017 (19512)	43704 (19824)	44562 (20213)	42651 (19346)

* At the centre of gravity distance 600mm. Based on 80% of FTTL as defined in ISO 8313.
Manual fork spacing's at 50mm increments. Class 4A forks (section 150mm x 60mm). HT machines have heavy duty counterweight

SERVICE FILL CAPACITIES

Hydraulic system	gal (liters)	63.4 (240)
Fuel tank	gal (liters)	79.3 (300)

STEERING Hydraulic power steering.

BRAKES Hydraulic power braking on all wheels. In-board mounted, oil immersed, multi-plate disc brakes. Parking brake, electro-hydraulic disc type operating on transmission output shaft.

NOISE AND VIBRATION

			Uncertainty	Measurement conditions.
Noise at the operator station	LpA	68 dB	+/- 1 dB	Determined in accordance with the test method defined in ISO 6396 and the dynamic test condition defined on 2000/14/EC.
Noise emission from the machine	LWA	102 dB	+/- 1 dB	Guaranteed equivalent sound power (external noise) determined in accordance with the dynamic test conditions defined in 2000/14/EC.
Whole body vibration	f/s ² (m/s ²)	2 (0.63)	+/- 0.36 f/s ² (0.11 m/s ²)	ISO 2631-1:1997 normalised to an 8h reference period and based upon a test cycle comprising of loader work (soil).
Hand-arm vibration	f/s ² (m/s ²)	<8.2 (2.5)	N/A	ISO 5349-2:2001 dynamic test conditions.

MATERIAL DENSITY

Material	Loose density lbs/yc ³ (kg/m ³)	Fill factor %	Material	Loose density lbs/yc ³ (kg/m ³)	Fill factor %
Snow (fresh)	337 (200)	110	Sodium chloride (dry) (salt)	2191 (1300)	85
Peat (dry)	674 (400)	100	Cement portland	2427 (1440)	100
Sugar beet	893 (530)	100	Limestone (crushed)	2579 (1530)	100
Coke (loose)	961 (570)	85	Sand (dry)	2613 (1550)	100
Barley	1011 (600)	85	Asphalt	2697 (1600)	100
Petroleum coke	1146 (680)	85	Gravel (dry)	2781 (1650)	85
Wheat	1230 (730)	85	Clay (wet)	2832 (1680)	110
Coal bitumous	1289 (765)	100	Sand (wet)	3186 (1890)	110
Fertiliser (mixed)	1736 (1030)	85	Fire clay	3506 (2080)	100
Coal anthracite	1763 (1046)	100	Copper (concentrate)	3877 (2300)	85
Earth (dry) (loose)	1938 (1150)	100	Slate	4720 (2800)	100
Nitrate fertiliser	2107 (1250)	85	Magnetite	5401 (3204)	100

BUCKET CAPACITIES

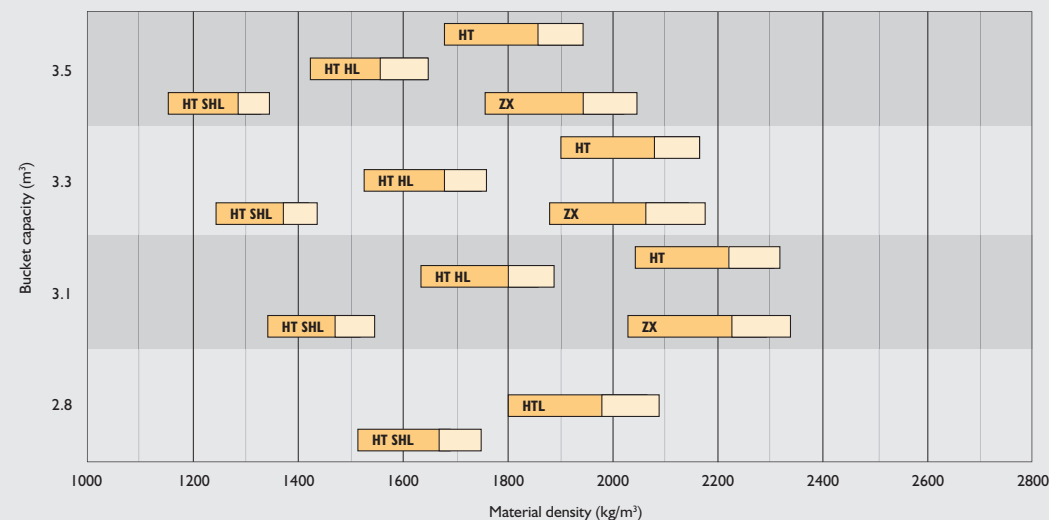

HT = Standard height arm HL = High lift arm SHL = Super high lift arm ZX = Z bar

100%
115% 95%
Bucket fill factors

EQUIPMENT

SERVICE AND MAINTENANCE

LiveLink telematics	•
Engine oil remote drain and fill	•
Grouped pressure test points	•
Lockable tool box	•
Lubrication points accessible from ground level	•

ENGINE

Air cleaner – cyclonic pre filter with engine fan scavenge system	•
Automatically reversing cooling fan	+
Crankcase breather oil trap	•
DEF fluid	•
Electrical opening rear hood	•
Epoxy coated radiator / coolers	+
Fixed mounted fan	•
Fuel filter	•
Fuel pre-filter with water trap	•
Hydraulically driven cooling fan	•
Manual override rear hood opening	•
-20° cold start	•
SCR DPF engine emission control	•
Swing out fan	+
Waste gated turbo	•
Widecore radiator	•
110v / 240v engine block heater	+

ELECTRICAL

120 amp alternator	•
Amber rotating beacon	•
Electrical adjustable mirrors	•
Heated mirrors	•
External battery isolator	•
Fold down beacon arm	•
Green seat belt beacon	+
Halogen front and rear work lights	•
LED front and rear work lights	+
360 degree LED work lights	+
Hazard warning lights	•
Integrated rear view camera	+
Number plate light kit	+
Parking lights	•
Radio wiring and speakers	•
Rear fog light	•
Reverse alarm and light	•
Reversing object detection system	+
Smart reverse alarm and light	+

ELECTRICAL (CONTINUED)

Turn signals	•
White noise reverse alarm and light	+
Work lights in rear grille	•
Hood operation alarm	•
Blue LED reverse lights	+

DRIVE TRAIN

5 speed transmission	•
5 speed transmission with lock-up torque converter	+
Operator controlled driving modes – Comfort & Dynamic	•
Epicyclical wheel hub reduction	•
Gear kick down on loader control lever	•
Indicator glass for transmission oil level	•
Loader lever direction control	•
Neutral start	•
Open differential	•
Open differential with automatic locking - 100% (front axle only)	+
Limited slip differentials front and rear	+
Oscillating rear axle	•
Power-inch intelligent clutch cut off on footbrake (selectable)	•
Selectable automatic power shift	•
Speed limiter 20km/h	+
Steering column single lever shift control (direction and gear)	•
Transmission cooler bypass	+

BRAKE SYSTEM

Multi-plate wet disc brakes	•
Sintered brake pads	•
Dual circuit hydraulic power	•
Wheel speed braking	•
Parking disc brake on transmission output shaft	•
Electrical hydraulic park brake actuation	•

OPERATOR STATION

Fully glazed cab	•
Windscreen guards	+
Air conditioning	•
Climate control	+
Single lever joystick	•
Multi-lever hydraulic controls	+
Proportional electro hydraulic auxiliary control	+
Air suspension cloth seat	•
Deluxe heated air suspension cloth seat	+
Super deluxe heated and cooled air suspension half leather seat	+
Front roller blind	•

OPERATOR STATION (CONTINUED)

Rear roller blind	+
Cab air intake filter	•
Carbon cab air intake filter	+
12V in cab power socket	•
2 x 12V in cab power socket	+
24V in cab power socket	+
Reversing camera (color)	•
Fold away adjustable steering column	•
ROPS/FOPS safety structure	•
Interior light	•
Front primary display screen	•
Secondary A post display screen, rotary control menu interface	+
A post mounted membrane switches	•
Variable fan speed control on climatic control system	+
2" (50 mm) seat belt	•
3" (75 mm) seat belt	+
Fire extinguisher (UK only)	+
Two speed intermittent front windscreen wipe/wash and self-park	•
Single speed rear windscreen wipe/wash and self-park	•
3 speed heater/demisting	•
LH and RH sliding opening windows	•
Floor mat	•
Cup holder	•
Steering wheel spinner knob	•
Internal rear view mirror	•
Tinted cab glass	•
Multi-media port (USB and 3.5mm)	+
Operator stowage	•
Laminated windscreen	•
Heated rear screen	•
Loader control isolator	•
Horn	•
Adjustable armrest	•
Removable storage rubber mats	•
Convex mirror kit (1 on each side)	+
Adjustable seat mounted controls	•
In-cab coolbox	+
Cab floor carpet	+

FRONT PRIMARY DISPLAY

Warning lights	
Direction indicators	•
Master warning	•
High coolant temperature	•
Battery charging condition	•

EQUIPMENT

FRONT PRIMARY DISPLAY (CONTINUED)

Warning lights (continued)	
Low fuel level	•
Engine oil pressure	•
Hazard lamps	•
Park brake state	•
Road lights	•
Main beam lights	•
Rear fog lights	•
Engine pre-heat	•
Brake system pressure	•
Differential lock	•
Low steering pressure	•
Buzzer alerts	
Engine air filter blocked	•
Diesel exhaust fluid (DEF)	•
Torque reduction in case of malfunction	•
Amber warning lamp	•
Stop engine	•
Gauge display	
Engine speed	•
Coolant temperature	•
Fuel level	•
LCD screen display	
Current gear	•
Stop engine	•
Torque reduction in case of malfunction	•
Amber warning lamp	•
Diesel exhaust fluid (DEF)	•
Engine air filter blocked	•
Secondary steer system pressure	•
Torque lockup	•
Steer mode	•
Ground speed	•
Engine speed (numeric display)	•
Clock	•
Hydraulic state	•
Smooth Ride System (SRS)	+
Beacon	•
Front work lamps	•
Rear work lamps	•
Heated rear screen	•
Transmission sump temperature	•
Data screens	
DEF level	•
Hydraulic oil temperature	•

FRONT PRIMARY DISPLAY (CONTINUED)

Data screens (continued)	
Torque convertor temperature	•
Volume of fuel remaining	•
Total fuel used (resettable)	•
Instantaneous fuel use	•
Average fuel use (resettable)	•
Current date	•
Machine hours	•
Trip distance (resettable)	•
Hours to service	•
Daily checks	
Engine oil level	•
DEF level	•
DPF status	•
RIGHT HAND SECONDARY DISPLAY (OPTIONAL)	
Clock	•
Climate control	•
Fan speed	•
In cab temperature set	•
Machine hours	•
Rear view camera	•
Fuel use	•
Time and date	•
Auxiliary flow rate	+
Hydraulic oil temperature	•
Transmission oil temperature	•
Auto engine shutdown	•
Machine settings screen	
Coolant temperature	•
Engine oil pressure	•
Air filter	•
Transmission sump oil temperature	•
Transmission torque convertor temperature	•
Hydraulic oil temperature	•
Park brake pressure	•
Battery voltage	•
Help display	•
On-screen handbook	•
HYDRAULIC SYSTEM	
Smooth Ride System (SRS)	+
Hydraulic quick hitch with in cab isolation	+
Auxiliary ARV kit	+
Auxiliary hydraulic service	+

HYDRAULIC SYSTEM (CONTINUED)

Twin auxiliary hydraulic service	+
Twin piston pumps with priority steer	•
Emergency steer back-up	•
JCB biodegradable hydraulic oil	+
Electronic hydraulic isolation	•
Automatic boom kick-out (detent)	•
Automatic bucket positioner	•
Front loader float	•
Indicator glass for hydraulic oil level	•
Hydraulic oil cooler	•
EXTERNAL EQUIPMENT	
Front and rear fenders	•
Full rear fenders	+
Front adjustable mud flaps	•
Front wheel spray guards	•
Rear fender chevrons	•
Full tire coverage fenders	•
Automatic greasing system	+
Grease gun and cartridge	+
One piece electrical opening hood	•
Mesh air intake screens	•
Flexible bottom step	•
Full width rear counterweight	•
Recovery hitch	•
Lifting / tie down lugs	•
Rear counterweight chevrons	+
Additional rear counterweight (+ 1706lb (+774kg))	+
PROTECTIVE EQUIPMENT	
Front cab screen guards	+
Wastemaster package: includes front and rear light guards, front screen guard, front and rear belly guards, rear light guards, Wastemaster decal.	+
Rear grille guard	+
Fire system	+
Safety strut loader arm	•
Light guards	+
Front belly guard kits	+
Rear belly guard kits	+
Articulation joint safety strut	•
Front rubber apron mat	+
OTHER EQUIPMENT	
High lift loader end (HT only)	+
Super high lift loader end (HT loader only)	+

STANDARD •
OPTIONAL +







ONE COMPANY, OVER 300 MACHINES.

Your nearest JCB dealer

Wheel Loader 457

Gross engine power: 282 hp (210 kW) | Operating weight: 44,090 lb (19,999 kg)
 Full turn tipping load: 29,696 lb (13,470 kg) | Standard shovel capacity: 4.6 yd³ (3.5m³)

JCB North America

2000 Bamford Blvd., Pooler, Georgia, 31322 Tel: (912) 447-2000

Download the very latest information on this product range at www.jcb.com

JCB inc. All rights reserved. No part of this publication may be reproduced, stored in a retrieval system, or transmitted in any form or by any other means, electronic, mechanical, photocopying or otherwise, without prior permission from JCB inc. All references in this publication to operating weights, sizes, capacities and other performance measurements are provided for guidance only and may vary dependant upon the exact specification of machine. They should not therefore be relied upon in relation to suitability for a particular application. Guidance and advice should always be sought from your JCB Dealer. JCB reserves the right to change specifications without notice. Illustrations and specifications shown may include optional equipment and accessories. The JCB logo is a registered trademark of J.C. Bamford Excavators Ltd.

9999/6088 en-GB | USA 5664 06/2021

f JCBNA @JCBNA JCBNORTHAMERICA JCBNA

