

FIG. 1

BASE MACHINE (INC STD EQUIPMENT - FIG. 1-3)
CALCULATED APPROX WEIGHT = 42,090 kg (92,792 lb)
 INCLUDES: - KOBELCO SK350LC-9 BASE MACHINE (800mm SHOES), ALL FLUIDS, UPRATED HOIST CYLS, BASE BOOM ASSY, TOP STD BOOM ASSY, OEM DIPPER CYL, OEM DIPPER, OEM ATTACHMENT CYL AND LINKAGE.
 TILTING CAB & GUARD (SUPPLIED BY COMPANY WRENCH) - 1361 kg (3000 lb)
 ADDITIONAL C/WT (SUPPLIED BY COMPANY WRENCH) - 3593 kg (7920 lb)

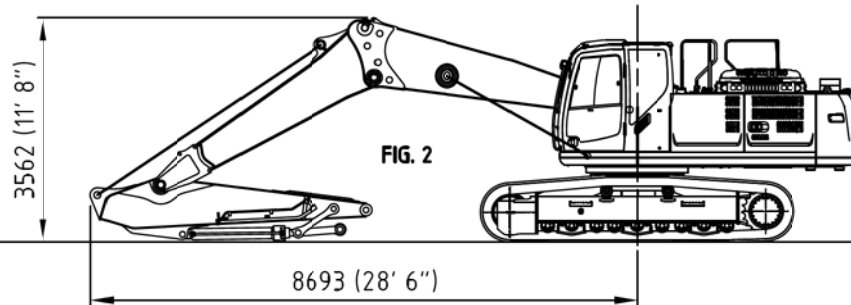

FIG. 2

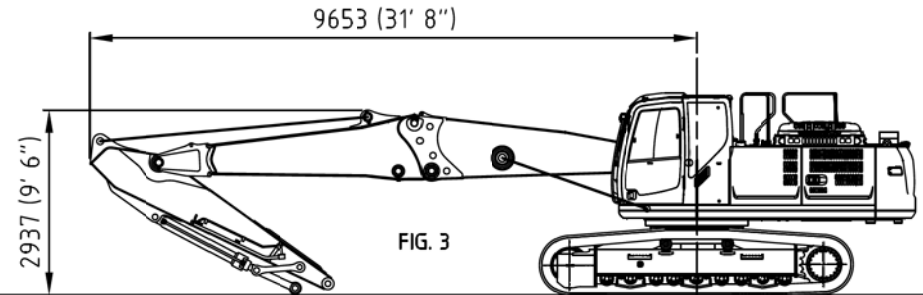

FIG. 3

FRONT EQUIPMENT (FIG. 4)

CALCULATED APPROX WEIGHT = 4590 kg (10,119 lb)

INCLUDES: - A-FRAME (135 kg / 298 lb), TOP STANDARD BOOM, OEM DIPPER, OEM DIPPER CYL, OEM ATTACHMENT CYLINDER AND LINKAGE.

BASE MACHINE (INC STD EQUIPMENT - FIG. 5)

CALCULATED APPROX WEIGHT = 37,638 kg (82,977 lb)

INCLUDES: - KOBELCO SK350LC-9 BASE MACHINE (800mm SHOES), ALL FLUIDS, UPRATED HOIST CYLS AND BASE BOOM ASSY.

TILTING CAB & GUARD (SUPPLIED BY COMPANY WRENCH) - 1361 kg (3000 lb)
 ADDITIONAL C/WT (SUPPLIED BY COMPANY WRENCH) - 3593 kg (7920 lb)

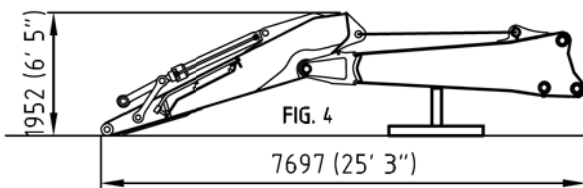

FIG. 4

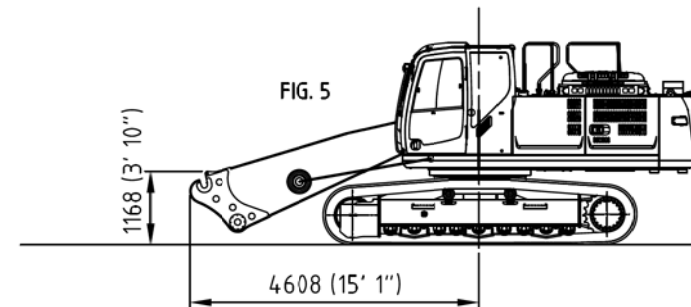

FIG. 5

NOTES:

1. ALL WEIGHTS AND DIMENSIONS APPROXIMATE - BASE MACHINE INFORMATION BASED ON OEM DATA.

2. FOR ADDITIONAL UNMODIFIED BASE MACHINE DATA SEE OEM LITERATURE.

				CONFIDENTIAL <small>This drawing embodies confidential information, the property of KOCUREK EXCAVATORS Ltd., to whom the copyright belongs. This drawing may not be copied or used for any purpose other than that for which it was made available except with the prior written consent of KOCUREK EXCAVATORS Ltd., & provision of this drawing does not grant any rights under any Industrial property rights of KOCUREK EXCAVATORS Ltd., nor of any third party.</small>		DIMENSIONS WITHOUT TOLERANCES X.X ±2.0 X.XX ±0.5 X.XXX ±0.2 ANGLES ±1°		ALL DIMS IN mm UNLESS OTHERWISE STATED		SCALE NTS IF IN DOUBT ASK DO NOT SCALE		DRAWN HAB DATE 01/12/16 MATERIAL - FINISH -		TITLE DATASHEET - TRANSPORT BASE MACHINE & M/J KOBELCO SK350LC-9 DRG. NO. 21061253 SHT 1 OF 2	
1	01/12/16	-	HAB	24 Arkwright Road Hadleigh Road Industrial Estate Ipswich IP2 0UB ENGLAND Tel. +44 (0)1473 217477											
ISS.	DATE	MOD	DRN.												

Lifting Capacities

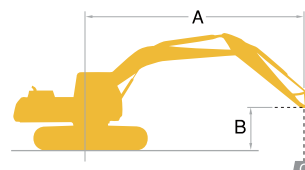

Rating over front



Rating over side or 90 degrees

A – Reach from swing centerline to arm tip
 B – Arm bucket pin height above/below ground
 C – Lifting capacities in pounds (kilograms)

KOBELCO

DRIVEN BY PASSION

Hydraulic Excavator

SK350 LC

SK350LC-10

- **Bucket Capacity :**
0.875 - 2.75 cu.yd. SAE
- **Engine Power :**
270 hp {201 kW} @ 2,100 rpm (SAE NET)
- **Operating Weight :**
83,300 lbs {37,800 kg}

SK350LC		Short Arm:8'6" (2.6 m), Without bucket, 31.5" (800 mm) track shoes								HEAVY LIFT		
B	A	10'(3.0 m)		15'(4.6 m)		20'(6.1 m)		25'(7.6 m)		At Max. Reach		
		Rating over front	Rating over side or 90 degrees	Rating over front	Rating over side or 90 degrees	Rating over front	Rating over side or 90 degrees	Rating over front	Rating over side or 90 degrees	Rating over front	Rating over side or 90 degrees	
25'(7.6 m)	lb(kg)									*19,430(8,810)	*19,430(8,810)	22'10"(6.97 m)
20'(6.1 m)	lb(kg)					*20,430(9,260)	*20,430(9,260)	*18,950(8,590)	17,240(7,810)	*18,900(8,570)	16,000(7,250)	26'1"(7.95 m)
15'(4.6 m)	lb(kg)			*29,000(13,150)	*29,000(13,150)	*22,740(10,310)	*22,740(10,310)	*19,740(8,950)	16,770(7,600)	*18,830(8,540)	13,930(6,310)	28'1"(8.56 m)
10'(3.0 m)	lb(kg)					*25,550(11,580)	22,060(10,000)	*21,040(9,540)	16,120(7,310)	*19,010(8,620)	12,890(5,840)	29'1"(8.86 m)
5'(-1.5 m)	lb(kg)					*27,810(12,610)	20,970(9,510)	*22,220(10,070)	15,530(7,040)	*19,340(8,770)	12,550(5,690)	29'2"(8.90 m)
Ground Level	lb(kg)			*38,830(17,610)	30,470(13,820)	*28,780(13,050)	20,360(9,230)	*22,750(10,310)	15,150(6,870)	*19,750(8,950)	12,840(5,820)	28'5"(8.66 m)
-5'(-1.5 m)	lb(kg)	*34,950(15,850)	*34,950(15,850)	*36,900(16,730)	30,570(13,860)	*28,140(12,760)	20,230(9,170)	*22,030(9,990)	15,100(6,840)	*20,110(9,120)	13,940(6,320)	26'8"(8.13 m)
-10'(-3.0 m)	lb(kg)	*41,880(18,990)	*41,880(18,990)	*32,850(14,900)	31,110(14,110)	*25,370(11,500)	20,550(9,320)			*20,150(9,130)	16,470(7,470)	23'9"(7.25 m)
-15'(-4.6 m)	lb(kg)			*25,130(11,390)	*25,130(11,390)					*18,890(8,560)	*18,890(8,560)	19'2"(5.85 m)

SK350LC		Standard Arm:10'10" (3.30 m), Without bucket, 31.5" (800 mm) track shoes								HEAVY LIFT								
B	A	5'(1.5 m)		10'(3.0 m)		15'(4.6 m)		20'(6.1 m)		25'(7.6 m)		30'(9.1 m)		At Max. Reach				
		Rating over front	Rating over side or 90 degrees	Rating over front	Rating over side or 90 degrees	Rating over front	Rating over side or 90 degrees	Rating over front	Rating over side or 90 degrees	Rating over front	Rating over side or 90 degrees	Rating over front	Rating over side or 90 degrees	Rating over front	Rating over side or 90 degrees			
25'(7.6 m)	lb(kg)									*15,570(7,060)	*15,570(7,060)			*12,940(5,860)	*12,940(5,860)	25'6"(7.78 m)		
20'(6.1 m)	lb(kg)									*17,460(7,910)	*17,460(7,910)			*12,470(5,650)	*12,470(5,650)	28'5"(8.67 m)		
15'(4.6 m)	lb(kg)							*21,180(9,600)	*21,180(9,600)	*18,600(8,430)	17,230(7,810)	*14,500(6,570)	12,880(5,840)	*12,470(5,650)	*12,470(5,650)	30'3"(9.23 m)		
10'(3.0 m)	lb(kg)							*32,700(14,830)	*32,700(14,830)	*24,300(11,020)	22,790(10,330)	*20,200(9,160)	16,540(7,500)	*17,920(8,120)	12,590(5,710)	*12,870(5,830)	11,820(5,360)	31'2"(9.51 m)
5'(-1.5 m)	lb(kg)							*37,630(17,060)	32,090(14,550)	*27,090(12,280)	21,570(9,780)	*21,730(9,850)	15,870(7,190)	*18,570(8,420)	12,260(5,560)	*13,690(6,200)	11,520(5,220)	31'3"(9.54 m)
Ground Level	lb(kg)							*39,410(17,870)	31,040(14,070)	*28,740(13,030)	20,770(9,420)	*22,720(10,300)	15,380(6,970)	*18,650(8,450)	12,040(5,460)	*15,100(6,840)	11,720(5,310)	30'7"(9.32 m)
-5'(-1.5 m)	lb(kg)							*34,880(15,820)	*34,880(15,820)	*38,670(17,540)	30,810(13,970)	*28,880(13,090)	20,440(9,270)	15,160(6,870)	*17,490(7,930)	12,530(5,680)	29'0"(8.84 m)	
-10'(-3.0 m)	lb(kg)	*39,310(17,830)	*39,310(17,830)	*48,720(22,090)	*48,720(22,090)	*35,730(16,200)	31,090(14,100)	*27,190(12,330)	20,520(9,300)	*20,940(9,490)	15,290(6,930)			*19,190(8,700)	14,330(6,490)	26'4"(8.04 m)		
-15'(-4.6 m)	lb(kg)			*39,470(17,900)	*39,470(17,900)	*29,860(13,540)	*29,860(13,540)	*22,490(10,200)	21,100(9,570)					*18,950(8,590)	18,320(8,300)	22'4"(6.80 m)		

SK350LC		Long Arm:13'7" (4.15 m), Without bucket, 31.5" (800 mm) track shoes								HEAVY LIFT																			
B	A	5'(1.5 m)		10'(3.0 m)		15'(4.6 m)		20'(6.1 m)		25'(7.6 m)		30'(9.1 m)		At Max. Reach															
		Rating over front	Rating over side or 90 degrees	Rating over front	Rating over side or 90 degrees	Rating over front	Rating over side or 90 degrees	Rating over front	Rating over side or 90 degrees	Rating over front	Rating over side or 90 degrees	Rating over front	Rating over side or 90 degrees	Rating over front	Rating over side or 90 degrees														
30'(9.1 m)	lb(kg)													*10,680(4,840)	*10,680(4,840)	24'4"(7.43 m)													
25'(7.6 m)	lb(kg)													*9,930(4,500)	*9,930(4,500)	28'4"(8.64 m)													
20'(6.1 m)	lb(kg)													*15,210(6,890)	*15,210(6,890)	*13,100(5,940)	*13,100(5,940)	*9,660(4,380)	*9,660(4,380)	31'0"(9.45 m)									
15'(4.6 m)	lb(kg)													*16,550(7,500)	*16,550(7,500)	*15,460(7,010)	12,940(5,860)	*9,710(4,400)	*9,710(4,400)	32'8"(9.97 m)									
10'(3.0 m)	lb(kg)													*45,490(20,630)	*45,490(20,630)	*28,330(12,850)	*28,330(12,850)	*21,730(9,850)	*21,730(9,850)	*18,340(8,310)	16,590(7,520)	*16,360(7,420)	12,510(5,670)	*10,040(4,550)	*10,040(4,550)	33'6"(10.23 m)			
5'(-1.5 m)	lb(kg)													*34,330(15,570)	32,570(14,770)	*24,950(11,310)	21,650(9,820)	*20,160(9,140)	15,770(7,150)	*17,340(7,860)	12,060(5,470)	*10,680(4,840)	10,110(4,580)	33'7"(10.25 m)					
Ground Level	lb(kg)													*24,650(11,180)	*24,650(11,180)	*37,260(17,120)	30,800(13,970)	*27,280(12,370)	20,550(9,320)	*21,580(9,780)	15,110(6,850)	*18,060(8,190)	11,690(5,300)	*11,730(5,320)	10,210(4,630)	33'0"(10.05 m)			
-5'(-1.5 m)	lb(kg)	*22,790(10,330)	*22,790(10,330)	*33,840(15,340)	*33,840(15,340)	*38,530(17,470)	30,080(13,640)	*28,270(12,820)	19,940(9,040)	*22,210(10,070)	14,710(6,670)	18,120(8,210)	11,500(5,210)	*13,440(6,090)	10,770(4,880)														
-10'(-3.0 m)	lb(kg)	*33,360(15,130)	*33,360(15,130)	*46,190(20,950)	*46,190(20,950)	*37,040(16,800)	30,060(13,630)	*27,680(12,550)	19,800(8,980)	*21,620(9,800)	14,620(6,630)			*16,420(7,440)	12,020(5,450)	29'1"(8.87 m)													
-15'(-4.6 m)	lb(kg)	*45,720(20,730)	*45,720(20,730)	*46,060(20,890)	*46,060(20,890)	*33,040(14,980)	30,590(13,870)	*24,940(11,310)	20,100(9,110)	*18,690(8,470)	14,960(6,780)			*18,000(8,160)	14,590(6,610)	25'6"(7.78 m)													
-20'(-6.1 m)	lb(kg)			*33,790(15,320)	*33,790(15,320)	*25,000(11,330)	*25,000(11,330)	*17,730(8,040)	*17,730(8,040)					*17,580(7,970)	*17,580(7,970)	20'1"(6.12 m)													

- Notes:
1. Do not attempt to lift or hold any load that is greater than these lift capacities at their specified lift point radius and heights. Weight of all accessories must be deducted from the above lift capacities.
 2. Lift capacities are based on machine standing on level, firm, and uniform ground. User must make allowance for job conditions such as soft or uneven ground, out of level conditions, side loads, sudden stopping of loads, hazardous conditions, experience of personnel, etc.
 3. Arm bucket pin, without bucket is defined as lift point.
 4. The above lifting capacities are in compliance with SAE J/ISO 10567. They do not exceed 87 % of hydraulic lifting capacity or 75 % of tipping load. Lifting capacities marked with an asterisk (*) are limited by hydraulic capacity rather than tipping load.
 5. Operator should be fully acquainted with the Operator's and Maintenance Instructions before operating this machine. Rules for safe operation of equipment should be adhered to at all times.
 6. Lift capacities apply to only machines as originally manufactured and normally equipped by KOBELCO CONSTRUCTION MACHINERY CO., LTD.

Note: This document may contain attachments and optional equipment that are not available in your area. It may also contain photographs of machines with specifications that differ from those sold in your area. Please contact your nearest KOBELCO dealer for items you require. Due to our policy of continuous product improvement, all designs and specifications are subject to change without advance notice. Copyright KOBELCO CONSTRUCTION MACHINERY CO., LTD. No part of this document may be reproduced in any manner without prior written permission from KOBELCO.

KOBELCO CONSTRUCTION MACHINERY U.S.A. INC.

22350 Merchants Way, Katy, Texas 77449
<http://www.kobelco-usa.com/>

Inquiries To:

Bulletin No. SK350LC-NA-101-160500N



Complies with the latest exhaust emission regulations



US EPA Tier IV Final



EU (NRMM) Stage IV



Japanese Regulations

Power Meets Efficiency

Increased POWER
means increased
PRODUCTIVITY

Greater fuel
economy means
higher efficiency

From urban centers to mines around the world, KOBELCO's all-out innovation brings you durable, Earth-friendly construction machinery that's equal to any task all over the planet. Increased power and better fuel economy bring greater efficiency to any project. The KOBELCO SK350LC Conventional Hydraulic Excavator is more durable than ever, able to withstand the rigors of the toughest job sites. Focusing on the global environment of the future, KOBELCO offers next-generation productivity to meet the need for lower life-cycle costs and exceed the expectations of customers the world over. It all adds up to new levels of value that are a step ahead of the times.



SK350_{LC}



More power and higher efficiency.

The highly efficient hydraulic system minimizes fuel consumption while maximizing power. With nimble movement and outstanding digging power, this excavator improves job productivity.

↑
About 5% increase

■ Digging volume/hour
(Compared to H-mode on previous models)

Increased POWER means increased PRODUCTIVITY

Power to do more, faster

Digging Volume

The SK350LC offers dynamic digging force even as it minimizes fuel consumption, achieving class-leading work volume. H-mode is used for maximum productivity, delivering 5% greater digging volume.

Heavy Lift

High hydraulic pressure (Heavy Lift) means greater lifting power, at close radius, allowing for smooth and steady operation while moving heavy objects.



Independent Travel

Selecting Independent Travel dedicates one hydraulic pump to travel and one to the attachment on a continuous basis, allowing for a smooth and constant movement speed even while swinging or using the boom or attachment. With Independent Travel, safely carrying a large pipe across a job site is a breeze.

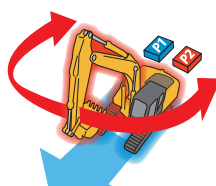

Swing Priority

Our exclusive system automatically and instantly delivers full swing power during combined operations. There's no need to mode-switch to make quick work of jobs like side-digging and back-filling.

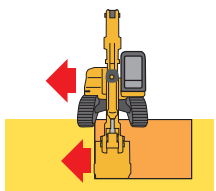

Power Boost

When you need more power instantly, engage Power Boost to get 10% more power with no time limit.

■ Max. Bucket Digging Force (ISO 6015)
With Power Boost: **56,200 lbs** {250 kN}

■ Max. Arm Crowding Force (ISO 6015)
With Power Boost: **40,500 lbs** {180 kN}

Drawbar Pulling Force (SAE J1309)

Excellent drawbar force lets you conquer rough terrain and slopes.

74,400 lbs {331 kN}

Conforms to Tier IV Final exhaust emissions standards

Reduces fuel consumption and minimizes exhaust emissions

The HINO engine, (a subsidiary of Toyota) is renowned for fuel efficiency and environmental performance, and KOBELCO has tuned them specifically for construction machinery. The high-pressure common rail fuel injection system, the variable-geometry (VG) turbocharger, reduce particulate matter (PM) while the large EGR cooler greatly reduces the formation of nitrogen oxide (NOx) gases.



VG turbo reduces PM

The variable-geometry turbocharger adjusts air intake to maximize combustion efficiency. At low engine speeds the nozzles are closed, the turbo speed increased and air intake is boosted. This helps lower fuel consumption.

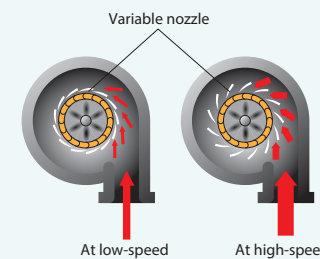

SCR System with DEF

NEW

Engine exhaust system utilizes Selective Catalytic Reduction (SCR) to convert NOx* into harmless nitrogen and water emissions. SCR combined with a Diesel Particulate Filter (DPF) makes a much cleaner machine meeting US EPA regulations for Tier IV final.

■ NOx reduction rate
(Compared to previous models)

About **80% decrease***

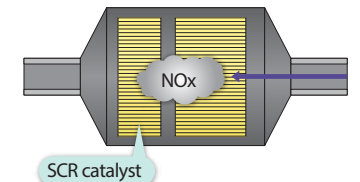

EGR cooler reduces NOx

Cooled exhaust gases from the EGR cooler are mixed with fresh air in the intake. The recirculated air lowers the combustion temperature which reduces NOx.

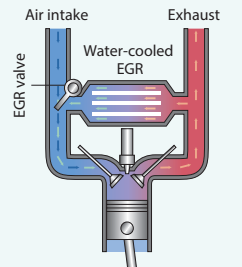

Revolutionary technology boosts efficiency and minimizes fuel consumption

Operation Mode

Improved fuel economy in ECO- and S-modes.

■ Compared to previous models

E ECO-mode ... About 8% improvement

S S-mode ... About 10% improvement

Greater fuel economy means higher efficiency

Always and Forever. Yesterday, Today, and Tomorrow. We're Obsessed with Fuel Efficiency.

Over the past 10 years, KOBELCO has achieved an average fuel consumption reduction of 47% across its fleet. We vow to lead the industry in improving fuel efficiency.

■ Compared to SK330LC-6 model (2006)

E ECO-mode (SK350LC-10) ... About 47% improvement

Boom to Arm Regeneration System

NEW

Innovative engineering uses the downward movement of the boom to push fluid to the arm. Gravity and kinetic energy greatly reduce the amount of power needed to move fluid through the system.

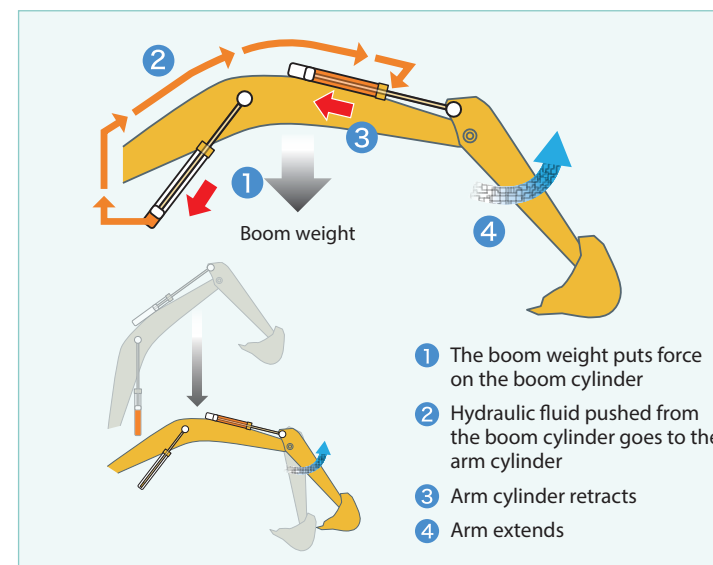

Hydraulic circuit reduces energy loss

Improved hydraulic line layout minimizes hydraulic pressure resistance from turbulence and valve restrictions. Fuel efficiency is increased because it takes less energy to move fluid through a circuit with low flow resistance.

Improved hydraulic piping is an effective means of reducing pressure loss.

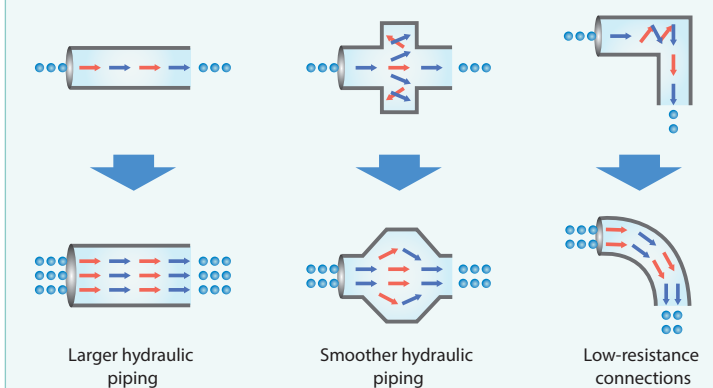

Increased power with enhanced durability to maintain the machine's value

Smart system design increases strength and eliminates hydraulic problems. Enhanced reliability and durability takes productivity to a new level.



Built to operate in tough working environments

Reinforced and redesigned boom and arm offers excellent durability during demanding work conditions to reliably handle higher work volume.

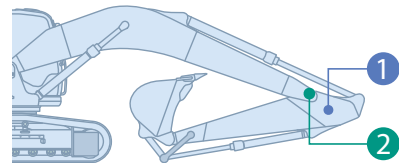

1 Enlarged reinforcement of the arm

Arm: Base plate thickness has been increased.

NEW

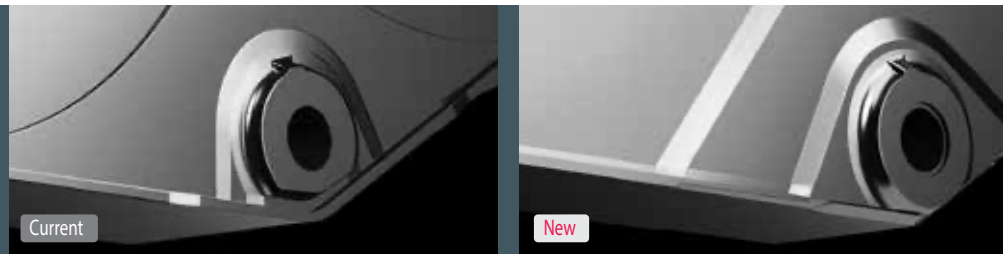

2 Modified foot boss shape

Arm foot boss shape has been changed to better distribute stress.

NEW



500 Hour Attachment Lubrication Interval

The self lubrication bushings are used at the attachment pins and the bushings with high abrasion resistant property are used at the pins around the bucket. The lubrication cycle of the lubrication points around the bucket is 250 hours and that of other lubrication points is 500 hours.



* Additionally the two piece bucket bushings protect the side of the arm from contact and then wear from the bucket ears. Should the bucket bushings need replacement, they can be replaced separately from the larger main bushing, reducing costs.

Three Track Guides

Three heavy-duty track guides installed on each crawler side frame assure stability in the most demanding situations.



Improved filtration system reliability

Clean, contaminant-free fuel and hydraulic fluid are essential to stable performance. The improved filtration systems reduce the risk of mechanical trouble and enhance longevity and durability.

Hydraulic fluid filter

NEW

Recognized as the best in the industry, our super-fine filter separates out even the smallest particles. A new cover prevents contamination when changing filters.



Long-life hydraulic fluid:
5,000 hours

Hydraulic fluid filter replacement cycle is
1,000 hours

Hydraulic fluid filter restriction indicator

NEW

Detects clogging by measuring the difference in pressure between incoming and outgoing hydraulic fluid. Detecting contaminants before they can get into the hydraulic fluid reservoir reduces the risk of damage to the hydraulic system.

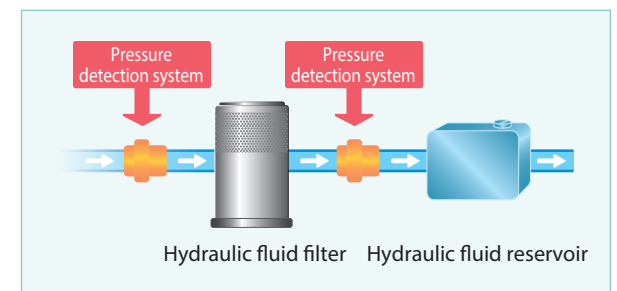

Double-element air cleaner

The large-capacity element features a double-filter structure that keeps the engine running clean even in industrial environments.



Fuel filter

NEW

Pre-filter with built-in water-separator maximizes filtering performance.

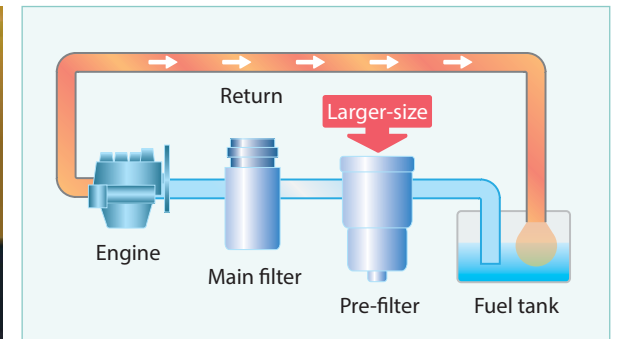

Comprehensive safety and intuitive operation

User-friendly design and enhanced safety means greater efficiency and productivity.



Safety

ROPS / FOPS CAB

ROPS (Roll-Over-Protective Structure)-compliant cab complies with ISO standards (ISO-12117-2: 2008) and ensures greater operator safety in the event of a roll-over. KOBELCO encourages operators to wear their seat belt during operation.



FOPS, Top Guard Level II. (Meets ISO10262)



Mounting brackets for vandalism guards are standard equipment (contact your KOBELCO dealer to fit vandalism or front rock guards).

Expanded field of view for greater safety



Left and right rear-view mirrors/Right bottom clearance mirror



Rear view from cab



Emergency escape hammer

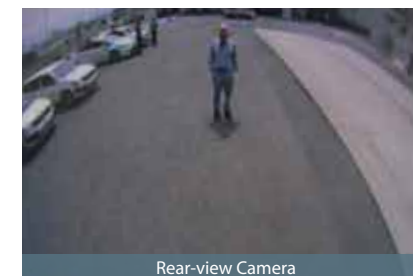

Rear-view Camera



Standard rear-view camera eases safety checks behind the machine. Color video displays on cab monitor.



Standard rear swing flashers and rear work lights.

Operator-friendly features that are easy to see, easy to use

Color Multi-display

Brilliant colors differentiate multiple graphics on cab LCD. Graphics indicate fuel consumption, maintenance intervals and more.

- 1 Analog-style gauges provide an intuitive reading of fuel level and engine temperature
- 2 Green indicates ECO mode selected or efficient operation in other modes
- 3 PM accumulation (left)/DEF level (right)
- 4 Fuel consumption/Rear-view camera
- 5 Digging mode switch
- 6 Monitor display switch

One-touch attachment mode switch

A simple flick of switch converts the hydraulic circuit and flow amount to match attachments. Helpful icons let the operator confirm the proper configuration at a glance.



PM accumulation/DEF level



Fuel consumption



Maintenance



Breaker mode



Nibbler mode



Independent Travel mode



Heavy Lift



Rear-view camera

Cab comfort takes a step ahead

The newly refined cab puts the operator first, ensuring a quieter, more comfortable work environment and easier operation.



Comfort

Climate control outlets behind the seat NEW



Five air outlets deliver warm or cool air directly to the operator.

A light touch on the lever means smoother, less tiring work NEW



It takes 25 % less effort to work the operation lever, which reduces fatigue over long working hours or continuous operations. *Compared to SK350LC-9 model

More comfortable seat means higher productivity



Quiet Inside



The high level of air-tightness ensures a quiet, comfortable cabin interior.

Interior equipment adds to comfort and convenience



Large door allows easy access in and out of the cab

The expanded cab provides plenty of room for a large door, more headroom and smoother entry and exit.



Low Vibration

Coil springs absorb small vibrations and high suspension mounts filled with silicone oil reduce heavy vibration. The long stroke achieved by this system provides excellent vibration protection.

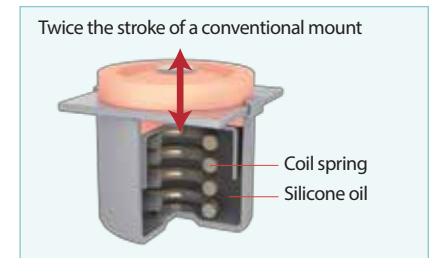

Wide, Open View Provides Excellent Visibility

The front window features one large piece of glass without a center pillar on the right side for a wide, unobstructed view.

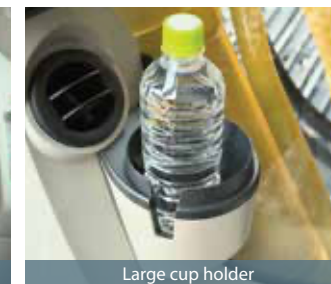

Efficient maintenance keeps the machine in peak operating condition



MAINTENANCE			
	INTERVAL	REMAINING TIME	EXCHANGE DAY
ENGINE OIL	500	495	--/--/--
FUEL FILTER	500	495	--/--/--
HYD. FILTER	1000	995	--/--/--
HYD. OIL	5000	4995	--/--/--

Examples of displaying maintenance information

Machine information display function

- Displays only the maintenance information that's needed, when it's needed
- Self-diagnostic function provides early-warning detection and display of electrical system malfunctions
- Service-diagnostic function makes it easier to check the status of the machine
- Record function for any possible on going or intermittent service issues

Easy, on-the-spot maintenance

NEW

Ample space in the engine compartment allows service staff to comfortably perform maintenance in a natural body position. The distance between access steps is smaller so getting to and from the engine compartment is easier. The hood is lighter and easier to raise and lower.

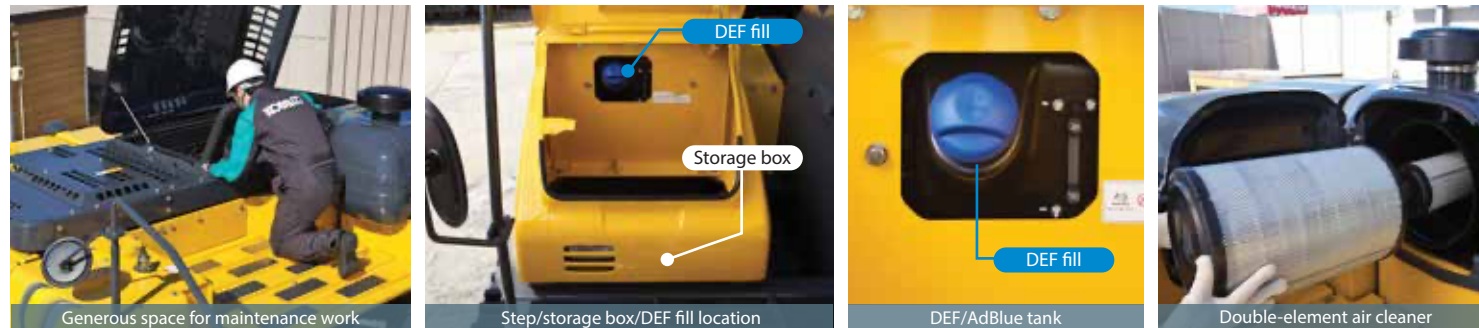

The DEF fill is located inside the convenient storage compartment.

Easy Access to In-cab Maintenance Features



Easy-access fuse box.



DPF Manual Regeneration Switch



Air conditioner filter can be easily removed without tools for cleaning. One for outside air and one for inside air.

Easy Cleaning



Special sloped crawler side frame design is easily cleaned of mud.



Detachable two-piece floor mat with handles for easy removal.



Fuel tank features bottom flange and large drain valve for easy maintenance.

Ground-level Access

Design allows for easy access at ground level for daily checks and maintenance work.



Laid out for easy access to radiator and cooling system elements

- 1 Main fuel filter with integrated water separator
- 2 Pre-fuel filter with integrated water separator
- 3 Engine oil filter

KOMEXS Total Support for Machines with Network Speed and Accuracy

KOMEXS is a satellite-based system for receiving machine information. Manage your machines anywhere in the world using the Internet. Location, workload and diagnostic data aid business operations.

Direct Access to Operational Status

Location Data

Accurate location data can be obtained even from sites where communications are difficult.

Operating Hours

A comparison of operating times of machines at multiple locations shows which locations are busier and more profitable. Operating hours on site can be accurately recorded, for running time calculations needed for rental machines, etc.

Fuel Consumption Data

Data on fuel consumption and idling times can be used to indicate improvements in fuel consumption.

Graph of Work Content

The graph shows how working hours are divided among different operating categories, including digging, idling, traveling, and optional operations (N&B).



Maintenance Data and Warning Alerts

Machine Maintenance Data

Provides maintenance status of separate machines operating at multiple sites. Maintenance data is also relayed to KOBELCO service personnel, for more efficient planning of periodic servicing.

Security System

Engine Start Alarm

Sends a notification if the engine is started outside of pre-defined hours.

Area Alarm

Sends a notification if the machine leaves a pre-defined area.

Engine

Model	HINO J08EVV-KSDK
Type	Water-cooled, 4cycle 6cylinder direct injection type diesel engine with intercooler turbo-charger (complies with EU (NRMM) Stage IV, EPA Tier IV Final)
No. of cylinders	6
Bore and stroke	4.41" {112 mm} x 5.12" {130 mm}
Displacement	468.9 cu.in {7.684 L}
Rated power output	270 hp {201 kW} / 2,100 rpm (SAE NET) 286 hp {213 kW} / 2,100 rpm (Without fan)
Max. torque	729 lb-ft {989 N-m} / 1,600 rpm (SAE NET) 750 lb-ft {1,017 N-m} / 1,600 rpm (Without fan)

Hydraulic System

Pump	Two variable displacement pumps + One gear pump
Type	Two variable displacement pumps + One gear pump
Max. discharge flow	2 x 77.7 U.S.gpm {2 x 294 L/min} 1 x 5.5 U.S.gpm {1 x 21 L/min}
Relief valve setting	
Boom, arm and bucket	4,970 psi {34.3 Mpa}
Power Boost	5,480 psi {37.8 Mpa}
Travel circuit	4,970 psi {34.3 Mpa}
Swing circuit	4,210 psi {29.0 Mpa}
Control circuit	725 psi {5.0 Mpa}
Pilot control pump	Gear type
Main control valves	8-spool
Oil cooler	Air cooled type

Swing System

Swing motor	Axial piston motor
Parking brake	Oil disc brake, hydraulic operated automatically
Swing speed	10 rpm {10 min ⁻¹ }
Swing torque	88,500 lb-ft {120 kN-m} (SAE)
Tail swing radius	11'10" {3,600 mm}
Min. front swing radius	14'2" {4,310 mm}

Bucket Selection Chart

Bucket type	Capacity (SAE) Cubic Yard {m ³ }	Width Inches {m}	Bucket Weight lb {kg}	Arm ft-in {m}		
				8'6" {2.60}	10'10" {3.30}	13'7" {4.15}
General Purpose	0.875 {.669}	24" {.609}	1,925 {873}	H	H	H
	1.25 {.956}	30" {.762}	2,105 {955}	H	H	H
	1.50 {1.146}	36" {.914}	2,365 {1,073}	H	H	M
	1.75 {1.337}	42" {1.066}	2,550 {1,157}	H	H	L
	2.0 {1.529}	48" {1.219}	2,700 {1,225}	M	M	X
	2.375 {1.815}	54" {1.371}	3,825 {1,735}	L	L	X
Heavy Duty	0.875 {.669}	24" {.609}	2,070 {939}	H	H	H
	1.25 {.956}	30" {.762}	2,265 {1,027}	H	H	H
	1.50 {1.146}	36" {.914}	2,545 {1,154}	H	H	M
	1.75 {1.337}	42" {1.066}	2,740 {1,243}	H	M	L
	2.0 {1.529}	48" {1.219}	2,905 {1,318}	M	L	X
	2.375 {1.815}	54" {1.371}	3,040 {1,379}	M	L	X
Severe Duty	1.00 {.764}	27" {.685}	2,330 {1,057}	H	H	H
	1.25 {.956}	33" {.762}	2,585 {1,172}	H	H	H
	1.50 {1.146}	36" {.914}	2,690 {1,220}	H	H	M
	1.75 {1.337}	42" {1.066}	2,945 {1,336}	H	M	L
	2.0 {1.529}	48" {1.219}	3,160 {1,433}	M	L	X

H - Used with material weight up to 3,000 lbs/cu yd {1,780 kg/m³} M - Used with material weight up to 2,500 lbs/cu yd {1,483 kg/m³}
L - Used with material weight up to 2,000 lbs/cu yd {1,186 kg/m³} X - Not recommended

Travel System

Travel motors	2 x Axial piston, two speed motors
Parking brakes	Oil disc brake per motors
Travel shoes	48 each side
Travel speed	3.7 / 2.2 mph {5.8 / 3.6 km/h}
Drawbar pulling force	74,400 lbs {331 kN} (SAE J 1309)
Gradeability	70 % {35 deg}
Ground clearance	1'8" {500 mm}

Cab & Control

Cab	All-weather, sound-suppressed steel cab mounted on the silicon-sealed suspension mounts and equipped with a heavy, insulated floor mat.
Control	Two hand levers and two foot pedals for travel Two hand levers for excavating and swing Electric rotary-type engine throttle

Boom, Arm & Bucket

Boom cylinder	2-5.5" {140 mm} x 5'1" {1,550 mm}
Arm cylinder	1-6.7" {170 mm} x 5'10" {1,788 mm}
Bucket cylinder	1-5.9" {150 mm} x 3'11" {1,193 mm}

Refilling Capacities & Lubrications

Fuel tank	132.9 U.S.gal {503 L}
Cooling system	9.2 U.S.gal {35 L}
Engine oil	7.5 U.S.gal {28.5 L}
Travel reduction gear	2x2.1 U.S.gal {2x8.0 L}
Swing reduction gear	2.0 U.S.gal {7.4 L}
Hydraulic oil tank	64.7 U.S.gal {245 L} tank oil level 108.3 U.S.gal {410 L} hydraulic system
DEF/AdBlue tank	21.9 U.S.gal {83 L}

Hydraulic P.T.O

Specification	Output	PSI {Mpa}	US gal {L} / min	
			2,100 rpm	1,000 rpm
N&B		4,980 {34.3}	155.3 {588}	37 {140}
Rotary		3,550 {24.5}	11.4 {43}	5.3 {20}

Working Ranges

Range	Arm	21'4" {6.50 m}		
		Short 8'6" {2.60 m}	Standard 10'10" {3.30 m}	Long 13'7" {4.15 m}
a - Max. digging reach		34'10" {10.61}	36'11" {11.26}	39'3" {11.97}
b - Max. digging reach at ground level		34'1" {10.4}	36'3" {11.06}	38'8" {11.79}
c - Max. digging depth		22'6" {6.86}	24'10" {7.56}	27'7" {8.41}
d - Max. digging height		33'8" {10.26}	34'9" {10.58}	35'1" {10.7}
e - Max. dumping clearance		23'2" {7.06}	24'2" {7.37}	24'8" {7.53}
f - Min. dumping clearance		10'11" {3.32}	8'7" {2.62}	5'10" {1.77}
g - Max. vertical wall digging depth		19'2" {5.84}	21'8" {6.61}	23'5" {7.15}
h - Min. swing radius		14'8" {4.46}	14'2" {4.31}	14'6" {4.43}
i - Horizontal digging stroke at ground level		13'10" {4.21}	19'1" {5.82}	23'8" {7.21}
j - Digging depth for 8 feet flat bottom		21'11" {6.67}	24'3" {7.4}	27'2" {8.27}
Bucket capacity SAE heaped cu.yd. {m ³ }		2.09 {1.60}	1.83 {1.4}	1.57 {1.20}

Dimensions

Arm length	Short 8'6" {2.60 m}	Standard 10'10" {3.30 m}	Long 13'7" {4.15 m}
A Overall length	37'4" {11,380}	37'1" {11,300}	37'2" {11,300}
B Overall height (to top of boom)	12'2" {3,700}	11'3" {3,420}	11'10" {3,600}
C Overall width	11'1" {3,390}**		
D Overall height (to top of cab)	10'6" {3,200}		
E Ground clearance of rear end*	3'11" {1,200}		
F Ground clearance*	1'8" {500}		
G Tail swing radius	11'10" {3,600}		
G' Distance from center of swing to rear end	11'10" {3,600}		
H Tumbler distance	13'3" {4,050}		
I Overall length of crawler	16'3" {4,960}		
J Track gauge	8'6" {2,590}		
K Shoe Width. In (mm)	2'7" {800}		
L Overall width of upperstructure	10'3" {3,120}		

* Without including height of shoe lug ** Shoe width : 2'7" {800 mm}

Operating Weight & Ground Pressure

In standard trim, with standard boom, 10'10" {3.30 m} arm, and 1.83 cu.yd. {1.40 m³} SAE heaped bucket

Shaped	Triple grouser shoes (even height)				
	In {mm}	23.6" {600}	27.6" {700}	31.5" {800}	35.4" {900}
Shoe width					
Ground pressure	psi {kPa}	10.0 {69}	8.7 {60}	7.7 {53}	7.0 {48}
Operating weight	lbs {kg}	80,700 {36,600}	82,500 {37,400}	83,300 {37,800}	84,200 {38,200}

STANDARD EQUIPMENT

ENGINE	<ul style="list-style-type: none"> Turbocharged and inter-cooled HINO J08EVV-KSDP Tier IV Final Diesel engine Automatic engine deceleration Two 12 V, 112 Ah batteries 24 V, 5 kW starting motor 60-amp alternator Removable radiator clean-out screen Automatic engine shut-down if low engine oil pressure Side by side oil, hydraulic and engine radiators Double-element air cleaner 	<ul style="list-style-type: none"> Lower track guards 	<ul style="list-style-type: none"> Handrails Heater and defroster Intermittent windshield wiper with double-spray washer Skylight FOPS top guard Tinted safety glass Pull-type front window and removable lower front window Easy to read multi-display monitor Automatic climate control Emergency escape hammer Bluetooth installed radio (AM/FM Stereo with speakers) Travel alarm Attachment pressure release switch Manual DPF regeneration switch 12 V converter Two-way control pattern changer
HYDRAULIC	<ul style="list-style-type: none"> Exclusive boom to arm regeneration systems Auto warm-up system Hydraulic oil cooler 		
MIRRORS & LIGHTS	<ul style="list-style-type: none"> Three rearview mirrors plus rear-view camera Two front working lights Swing flashers 		
CONTROL	<ul style="list-style-type: none"> Working mode selector (H-mode, S-mode and ECO-mode) Heavy Lift and Power Boost "without time limit" 	<ul style="list-style-type: none"> CAB & CONTROL ROPS / FOPS cab Two pilot-operated control levers Electric horn Integrated left-right slide-type control box All-weather, sound-insulated cab Interior cab light Coat hook Luggage tray Large cup holder Detachable two-piece floor mat 7-way adjustable suspension seat Headrest 	
SWING SYSTEM & TRAVEL SYSTEM	<ul style="list-style-type: none"> Swing rebound prevention system Independent travel system Two-speed travel with automatic down shift Sealed & lubricated track links 31'5" {800 mm} shoes are standard Grease-type track adjusters Automatic swing brake 		<ul style="list-style-type: none"> 600 mm, 700 mm and 900 mm shoes are optional. Air suspension seat CAB two light Right side camera Rain visor

OPTIONAL EQUIPMENT

600 mm, 700 mm and 900 mm shoes are optional.
Air suspension seat
CAB two light
Right side camera
Rain visor

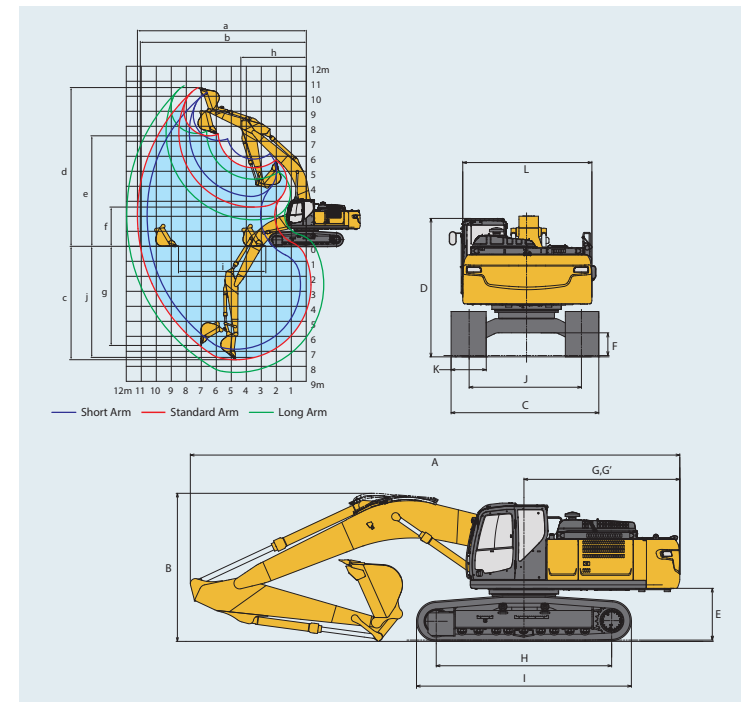

Digging Force

Arm length		Unit: lbs {kN}		
		Short 8'6" {2.60 m}	Standard 10'10" {3.30 m}	Long 13'7" {4.15 m}
Bucket digging force (Power boost)	SAE	45,900 {204} (50,600 {225})	45,900 {204} (50,600 {225})	45,900 {204} (50,600 {225})
	ISO	51,000 {227} (56,200 {250})	51,000 {227} (56,200 {250})	51,000 {227} (56,200 {250})
Arm crowding force (Power boost)	SAE	44,100 {196} (48,600 {216})	37,100 {166} (39,600 {176})	30,800 {137} (33,700 {150})
	ISO	45,900 {204} (50,600 {225})	37,100 {165} (40,700 {181})	31,500 {140} (34,600 {154})