

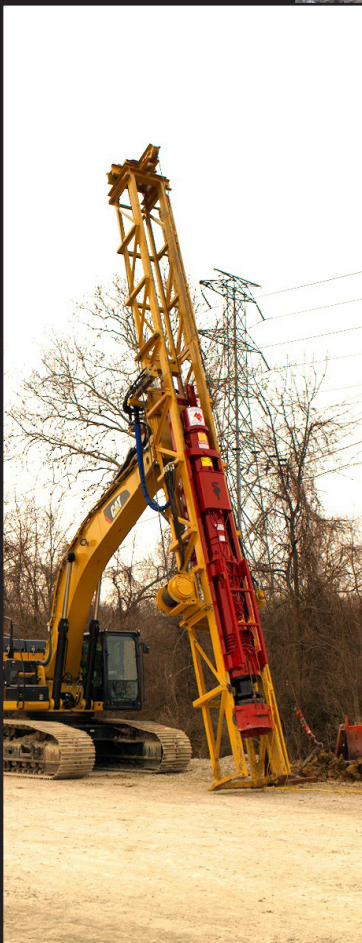

New MKT Excavator Mounted Lead System (ELS)



New MKT Excavator Mounted Lead System (ELS) 26-45 VT

MKT Excavator Mounted Lead System Overview:

- 20' BASE section for low-headroom applications
- Up to 45' overall length of 8" x 26" box leads
- 17,000 lb line pull TOOL winch, 34,000 pound line pull w/ cable 2-parted
- 12,000 lb line pull SERVICE winch for various hoisting requirements (piling, auger flighting, etc.)
- 8' vertical travel assembly
- 10° side-to-side adjustment for lead/pile plumbing
- Fore/aft capability (engineering review required based on tool & pile weight)
- Head sheave assembly & boom adapter
- Powered by excavator's hydraulics
- Modular system designed to fit specific customer needs
- In cab, operator friendly joystick controls for system functions
- Easily attached

MKT ELS 26-45 VT System Excavator Requirements:

- Excavator weight (includes stick & bucket cylinder...weight does not include bucket) = 110,000 lbs
- Auxiliary Circuit hydraulic flow required = 100 to 150 gpm
- Maximum hydraulic pressure required = Up to 5075 psi (depending on tool being used in ELS system)
- 24 volt negative ground electrical system

MKT ELS Components Weights:

- 20' base section (12,000 lbs) - includes boom adapter, vertical travel system, hydraulic control valve, tool and service winches.
- Complete ELS 26-45 VT system with 45' overall length of 8" x 26" box leads and head sheave assembly (17,000 lbs)

Tools Available for use in MKT ELS System:

- MKT HA-18 hydraulic auger system without flighting (2,250 lbs)
 - MKT HVA-40 variable torque hydraulic auger system without flighting (3,500 lbs)
 - MKT V-5E hydraulic vibratory hammer (does not include side-clamp assembly) (6,200 lbs)
 - MKT V-22 hydraulic vibratory hammer (8,750 lbs)
 - SPI D-19 single-acting diesel hammer with cap and striker plate (11,365 lbs)
 - SPI D-30 single-acting diesel hammer with cap and striker plate (18,005 lbs)
- **When using the MKT HVA-40, MKT V-22 and the SPI D-30 pile hammer tools, the main winch line must be 2-parted.

Distributed by:



MKT Manufacturing, Inc.

1198 Pershall Rd • St. Louis, MO 63137
phone (314) 388.2254 • fax (314) 388.1218
www.MKTPILEMAN.com

KOBELCO

**DRIVEN BY
PASSION**

Hydraulic Excavators

SK500 LC

■ Bucket Capacity :
1.77 - 3.14 cu.yd. SAE

■ Engine Power :
345 hp {257 kW} / 1,850 rpm
(SAE NET)

■ Operating Weight :
111,400 lbs {50,500 kg}



Note: This catalog may contain attachments and optional equipment that are not available in your area. It may also contain photographs of machines with specifications that differ from those of machines sold in your area. Please consult your nearest KOBELCO distributor for those items you require. Due to our policy of continuous product improvements all designs and specifications are subject to change without advance notice. Copyright by **KOBELCO CONSTRUCTION MACHINERY CO., LTD.** No part of this catalog may be reproduced in any manner without notice.

KOBELCO CONSTRUCTION MACHINERY U.S.A. INC.

4690 World Houston Parkway Houston, TX 77032
<http://www.kobelco-usa.com/>

Inquiries To:

Bulletin No. SK500LC-9-NA-301

2013080000E Printed in USA



The Power Wave of Change

"Genuine KOBELCO is Back!" excavators provide the three E's:

Enhancement, Economy and Environment!

The refining of each of these "E's", together with the introduction of leading-edge technology that complies with US EPA Interim Tier 4 emission standards provides excavators with even more enhanced environmental performance and fuel efficiency, as well as unparalleled work performance.

The incredible work rate of these excavators is provided by powerful digging strength and a wide digging range. These excavators feature a Hino engine with reduced environmental impact and Kobelco's unique technology that reduces pressure-loss resistance.

Kobelco's reliable and well-tested technology has been developed over many years, making it more than capable of satisfying the various demands of today's construction industry.

Continuously creating original value, Kobelco has been able to bring technical marvels into existence through a spirit of perpetual pursuit.



Enhancement

Greater Performance Capacity

- Reduced fuel consumption with highly efficient productivity
- New environmental engine with superior fuel efficiency and low fuel consumption hydraulic circuitry
- Powerful arm bucket digging strength and wide digging range

Economy

Improved Cost Efficiency

- Adoption of new "ECO-Mode" greatly reduces fuel consumption
- Easy maintenance that reduces upkeep costs
- High structural durability and reliability that retain machine value longer

Environment

Features That Go Easy on the Earth

- Compliance with US EPA Interim Tier IV regulations
- Low-noise and low vibration including improvements to sound quality

Fuel Consumption Rate

(Comparison with ACERA MARK 8 in S-Mode/Eco-Mode)

- **13%**
approximately

PM Reduction Rate

- **88%**
approximately

Digging Volume per Liter of Fuel

(Comparison with ACERA MARK 8 in S-Mode/Eco-Mode)

+ **8%**
approximately

More Work with Less Fuel!

Top-Class Powerful Digging (SAE J 1179:1990)

- Max. arm crowding force: 43,800 lbs {195kN}
- Max. arm crowding force with power boost: 48,100 lbs {214kN}
- Max. bucket digging force: 52,600 lbs {234kN}
- Max. bucket crowding force with power boost: 57,500 lbs {256kN}

Great Swing Power, Short Cycle Times

- Swing speed: 7.8 rpm

Powerful Travel

- Drawbar pulling force: 93,300 lbs {415kN}

Digging Volume per Liter of Fuel

(Comparison with ACERA MARK 8 in S-Mode/Eco-Mode)

+ approximately 8%

- H-Mode : + approximately 6%
- S-Mode : + approximately 5%

Energy Saving System

Fuel Consumption Rate

(Comparison with ACERA MARK 8 in S-Mode/Eco-Mode)

- approximately 10%

Hydraulic Circuit with Reduced Energy Loss

The KOBELCO original hydraulic circuit analysis is used to construct the hydraulic system with extremely reduced energy loss that contains a piping design for minimal back pressure losses resistance and the minimum valve resistance.



ECO-Mode

The ECO-mode is newly provided in this machine. The control of the engine and hydraulic pressure at this mode makes for a significant reduction in fuel consumption possible. Each mode for each work situation and circumstance can be selected easily from the menu.

Each Mode Reduces Fuel Consumption (Comparison with Previous Model)



- H-Mode** approximately 6% ↓ Suitable for a heavy workload
- S-Mode** approximately 6% ↓ Suitable for a good balance between workload and fuel consumption
- NEW E-Mode** approximately 13% ↓ Suitable for a severe priority on low fuel consumption at a light workload

Eco-Friendly Engine (No exhaust fluid required)

PM Reduction Rate

- approximately 88%

A State of the Art Developed Engine

The HINO engine, (a subsidiary of Toyota) established a reputation for low fuel consumption and environmental performance. This machine adopts this engine and KOBELCO fine tunes the match between the engine and hydraulic systems for the optimum combination of efficiency, operability, and environmental conscientiousness.



PM emissions cut: Limits creation of particulate matter (which results from incomplete combustion of fuel)

- Common rail system**
High-pressure injection atomizes the fuel, and injection timing is more precise, improving combustion efficiency.
- VG turbo**
The opening of the exhaust side nozzles in the variable-geometry turbocharger adjusts air intake to maximize combustion efficiency. At low engine speeds the nozzles are closed, then the turbo speed is increased and air intake is boosted. This helps lower fuel consumption.
- Diesel Particulate Filter (DPF)**
Carbon is built up as soot on the diesel particulate filter and is burned off at high temperature. No Exhaust fluid required. The system allows for manual or automatic filter regeneration.

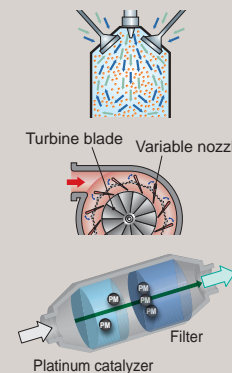

NOx emissions cut: Reduces nitrogen oxides (created by reaction with oxygen at high temperature)

- EGR cooler**
While ensuring sufficient oxygen for combustion, cooled exhaust gases are mixed with the air intake and re-circulated into the engine. Then the oxygen concentration is lowered and the combustion temperature is lowered.

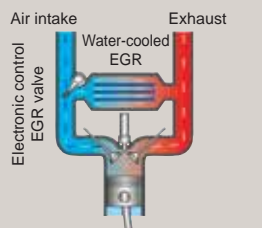

Color Multi-Display

The easy-to-read liquid crystal color multi-display, which has vivid colors and graphical indications, is provided within the new type console.



- The instantly understandable analogue gauge for fuel level and engine coolant temperature.
- The green indicator lights on at the low fuel consumption operation.
- The display can be switched between the fuel consumption graph or the view of the rear view visibility monitoring camera.
- All switches such as the work mode select switch are conveniently gathered here.

Designed from the Operator's Point of View

Comfortability

Big Cab

The "Big cab" provides a roomy operating space with plenty of legroom, and the door opens wide for entry and exit. As well as giving a wide, open view to the front, the cab has increased window areas on both sides and to the rear, for improved visibility in all directions.



Excellent Visibility

Eliminating the right-side cab support to make a single window has improved visibility to the right.

- Eliminating the right-side cab support to make a single window has improved wide visibility.
- The view is not obstructed by the provided rise up wiper when the wiper is not used.
- Safety check is easy with the left and right rearview mirrors, right lower mirror, and rearward visibility monitoring camera.
- The tempered green glass complied with European Standards is adopted.

Safety

ROPS Cab

The newly developed, ROPS (Roll-Over -Protective Structure)-compliant cab clears ISO standards(ISO-12117 -2: 2008) and ensures greater safety for the operator.



- FOPS guard (Meets or exceeds current OHSA standards)



- Level 2 FOPS Guard (ISO 10262) is equipped as standard.
- To fit vandalism guards or front rock guards, please contact your KOBELCO dealer. (Mounting brackets for vandalism guards provided standard)

Wide-Access Cab Helps Smooth Entry and Exit

Easy entry and exit assured with wider cab entry and safety lock lever integrated with mounting for control levers.



Comfortable Operating Environment

The inside of the cab is fully equipped for operator comfort. For example, the seat has many adjustment points for operating the machine and also when relaxing in the cab. A larger storage space is provided. Operator comfort was the first priority in mind when designing the cab.



Reclining seat



Double slide seat



Powerful automatic air conditioner



Two-speaker FM/AM radio with station select



Large cup holder



Spacious luggage tray

Rear View Camera

A rear view camera is installed as standard equipment to simplify checking for rear view behind the machine. The brilliant color picture appears on the LCD monitor.



Safety Features That Take Various Scenarios into Consideration



- Protective panel separates the pump compartment from the engine



- Swing flashers / rear working lights



- Hammer for emergency exit

- Hand rails are complied with European Standards
- Thermal guard prevents contact with hot components during engine inspections
- Travel alarm
- Retractable seatbelt requires no manual adjustment

The Value and Quality of Sturdy Construction!



Attachment and frame structures are designed for maximum durability

The use of forgings and castings in and around the front attachments minimizes stress concentrations in the Kobelco standard Heavy Duty Booms and arms. The side frames and car body structures are also optimized for heavy duty service and long life via the use of thicker axles at the side frame attachment and a heavy cross section of the complete structure.

Quality of Durability

The high quality urethane paint is applied to the machine body to keep the machine body beautiful for a long time. The bolt on handrail is attached to the cab for an easy repair and a special high durability seat covering is used for long life and cool operation on the operator's seat.



500 Hour Attachment Lubrication Interval

The self lubrication bushings are used at the attachment pins and the bushings with high abrasion resistant property are used at the pins around the bucket. The lubrication cycle of the lubrication points around the bucket is 250 hours and that of other lubrication points is 500 hours.



New-Design Fuel Filter Catches 95% of Dust and Impurities

The large-capacity fuel filter is designed specifically for common rail engines. With an increased filtering performance, this high-grade filter catches 95% of all dust particles and other impurities in the fuel.



Track Guides Installed in Four Places

Four heavy duty track guides, on each crawler side frame are installed as standard equipment. This assures track stability in the most demanding situations.



Long-Life Hydraulic Oil Reduces Replacement Costs

The long-life hydraulic oil features a base oil with excellent demulsification, with optimized wear-resistant additives and antioxidants that help to boost the service life to 5,000 hours and greatly reduces the number of changes necessary.

Long-life hydraulic oil
5,000 hours

Highly Durable Super-fine Filter (Hydraulic oil filter)

The high-capacity hydraulic oil filter incorporates glass fiber with superior cleaning power and durability. With a replacement interval of 1,000 hours and a construction that allows replacement of the filter element only, it is both highly effective and highly economical.



Super-fine filter

Double-Element Air Cleaner as Standard

The large-capacity element features a double-filter structure that keeps the engine running clean even in dusty environments.



Potentiometer for Emergency Mode and Controls Permits Continued Operation in the Unlikely Event of Malfunction



If unexpected trouble is experienced with the ITCS mechatronic control system, the machine can still be operated using the emergency acceleration system. Digging modes are also automatically relayed to an emergency system so that digging can continue with minimum down time.

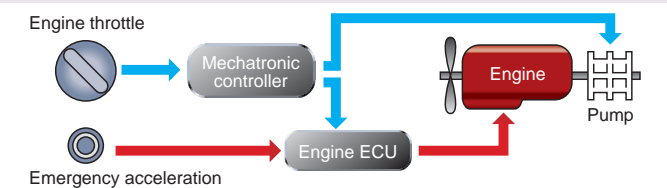

Newly designed MCU (Memory Control Unit)



New MCU Conventional MCU

- Vertical alignment and sealed cover gives better protection from water and dust
- Integration in base plate boosts assembly quality
- Reliable fixture to base plate

Countermeasures Against Electrical System Failure

All elements of the electrical system, including the controller, are mounted INSIDE the cab for increased reliability.

Fast, Accurate and Low-Cost Maintenance



Machine Information Display Function Is Essential for Accurate Maintenance

- When necessary, only the maintenance required item is displayed by the maintenance information display function.
- Malfunction at the electrical system is detected and displayed in the early stage by the self-diagnostic function.
- The machine condition can be easily checked by the service diagnosis function.
- Malfunction including irregular and transient one can be checked by the trouble history record function.



- Engine Oil Exchange
- Fuel Filter Exchange
- Hydraulic Oil Filter Exchange
- Hydraulic Oil Exchange

Maintenance from the Ground with Comfortable Working Posture

The components and parts those are subjected to be checked in daily inspection and periodic maintenance are provided at the accessible positions from the ground. This machine is designed with easy inspection and maintenance in mind.

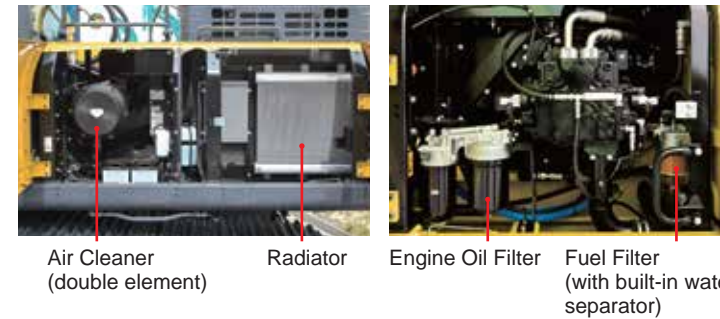

Air Cleaner (double element) Radiator Engine Oil Filter Fuel Filter (with built-in water separator)

Safety Maintenance from the Machine

The steps to the machine upper surface become three steps and the handrail complied with ISO standards is adopted. These are provided for safety maintenance from the machine.



Handrails Front mounted three steps instead of only two for easy safe access.

Easy-to-Access Inside Cab Helps Easy Inspection



Easy-access fuse box. DPF Manual Regeneration Switch Hour meter can be checked while standing on the ground. Air conditioner filter can be easily removed without tools for cleaning. One for outside air and one for inside air.

Easy-to-Clean Parts Shorten the Cleaning Time



Special sloped crawler side frame design is easily cleaned of mud. Detachable two-piece floor mat with handles for easy removal. Fuel tank drain valve.

Total Support for Machines with Network Speed and Accuracy

Our "KOMEX" allows you to use the Internet to manage information from your office for machines operating in all areas. Be prepared for any problems with strategic information and cost management. This provides a wide range of support for your business operations.

Direct Access to Operational Status

- Location Data**
Accurate location data can be obtained even from sites where communications are difficult.
- Operating Hours**
A comparison of operating times of machines at multiple locations shows which locations are busier and more profitable. Operating hours on site can be accurately recorded, for running time calculations needed for rental machines, etc.
- Fuel Consumption Data**
Data on fuel consumption and idling times can be used to indicate improvements in fuel consumption.
- Graph of Work Content**
The graph shows how working hours are divided among different operating categories, including digging, idling, traveling, and optional operations (N&B).
- Graph of Machine Duty Cycles**



Maintenance Data and Warning Alerts

- Machine Maintenance Data**
Provides maintenance status of separate machines operating at multiple sites. Maintenance data is also relayed to KOBELCO service personnel, for more efficient planning of periodic servicing.

Security System

- Engine Start Alarm**
The system can be set an alarm if the machine is operated outside the designated time.
- Area Alarm**
It can be set an alarm if the machine is moved out of its designated area to another location.

Engine

Model	HINO PC11CVC
Type:	Direct injection, water-cooled, 4-cycle electrically-controlled rail system type diesel engine with turbocharger, intercooler (Complies with EU (NRMM) Stage IIIB, EPA Interim Tier IV, and act on regulation, etc. of emission from non-road special motor vehicles (Japan))
No. of cylinders:	6
Bore and stroke:	4.80" (122 mm) x 5.91" (150 mm)
Displacement:	642 cu.in (10.52 L)
Rated power output:	345 hp {257 kW} / 1,850 rpm (SAE NET)
Max. torque:	1050 lb-ft {1,428N·m} / 1,400 rpm (SAE NET)

Hydraulic System





Pump	
Type:	Two variable displacement pumps + 1 gear pump
Max. discharge flow:	2 x 97.8 U.S.gph {2 x 370L/min}, 1 x 7.9 U.S.gph {1 x 30L/min}
Relief valve setting	
Boom, arm and bucket:	4,550 psi {31.4 Mpa}
Power Boost:	4,970 psi {34.3 Mpa}
Travel circuit:	4,970 psi {34.3 Mpa}
Swing circuit:	3,740 psi {25.8 Mpa}
Control circuit:	725 psi {5.0 Mpa}
Pilot control pump:	Gear type
Main control valves:	6-spool
Oil cooler:	Air cooled type

Swing System

Swing motor:	2 x axial piston motor
Parking brake:	Oil disc brake, hydraulic operated automatically
Swing speed:	7.8 rpm
Swing torque:	130,600 lb-ft {177 kN·m} (SAE)
Tail swing radius:	12'3" {3,740 mm}
Min. front swing radius:	16'10" {5,140 mm}

Attachments

Backhoe bucket and arm combination

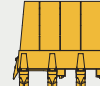
Use	Backhoe bucket					
	Normal Digging		Wide			
						
Bucket capacity	SAE heaped cu.yd.{m³}	1.77 {1.35}	2.09 {1.6}	2.49 {1.90}	2.75 {2.10}	3.14 {2.40}
	SAE Struck cu.yd.{m³}	1.31 {1.00}	1.51 {1.15}	1.83 {1.40}	1.96 {1.50}	2.22 {1.70}
Opening width	With side cutter inches {mm}	48 {1,225}	54 {1,375}	66 {1,670}	69 {1,750}	78 {1,980}
	Without side cutter inches {mm}	43 {1,100}	49 {1,250}	61 {1,550}	64 {1,630}	73 {1,860}
No. of bucket teeth		4	4	5	5	5
Bucket weight	lbs {kg}	2,760 {1,250}	2,930 {1,330}	3,330 {1,510}	3,440 {1,560}	3,730 {1,690}
Combinations	9'10" {3.00m} arm	○	○	○	◎	△
	11'4" {3.45m} arm	○	○	◎	△	×
	13'3" {4.04m} arm	-	◎	-	-	△
	16'1" {4.90m} arm	◎	△	△	×	×

○ Standard ○ Recommended △ Loading only × Not recommended

Travel System

Travel motors:	2 x axial piston, two-speed motors
Parking brakes:	Oil disc brake per motor
Travel shoes:	50 each side
Travel speed:	3.4 / 2.1 mph {5.4 / 3.4 km/h}
Drawbar pulling force:	93,300 lbs {415 kN} (SAE J 1309)
Gradeability:	70 % {35°}
Ground clearance:	20.1" (510 mm)

Cab & Control

Cab	
All-weather, sound-suppressed steel cab mounted on the silicon-sealed viscous mounts and equipped with a heavy, insulated floor mat.	
Control	
Two hand levers and two foot pedals for travel	
Two hand levers for excavating and swing	
Electric rotary-type engine throttle	

Boom, Arm & Bucket

Boom cylinder:	6.7" {170 mm} x 5'3" {1,590 mm}
Arm cylinder:	7.5" {190 mm} x 6'6" {1,970 mm}
Bucket cylinder:	6.3" {160 mm} x 4'8" {1,410 mm}

Refilling Capacities & Lubrications

Fuel tank:	169.1 U.S.gal {640 L}
Cooling system:	12.5 U.S.gal {47.4 L}
Engine oil:	11.2 U.S.gal {42.5 L}
Travel reduction gear:	2 x 4.0 U.S.gal {2 x 15L}
Swing reduction gear:	1.2 U.S.gal {4.7 L}
Hydraulic oil tank:	74.8 U.S.gal {283 L} tank oil level 142.1 U.S.gal {538 L} hydraulic system

Working Ranges

Range	Arm	23'0" {7.00m}			
		Short 9'10" {3.00m}	Standard 11'4" {3.45m}	Semi Long 13'3" {4.04m}	Long 16'1" {4.90m}
a - Max. digging reach		38'7" {11.77}	39'7" {12.07}	41'4" {12.61}	44'3" {13.48}
b - Max. digging reach at ground level		37'10" {11.54}	38'10" {11.84}	40'8" {12.40}	43'7" {13.28}
c - Max. digging depth		24'2" {7.36}	25'7" {7.81}	27'7" {8.40}	30'5" {9.26}
d - Max. digging height		36'7" {11.16}	35'10" {10.93}	36'6" {11.14}	38'5" {11.70}
e - Max. dumping clearance		25'4" {7.72}	24'10" {7.58}	25'7" {7.79}	27'2" {8.29}
f - Min. dumping clearance		10'7" {3.22}	9'1" {2.77}	7'2" {2.18}	4'4" {1.32}
g - Max. vertical wall digging depth		21'11" {6.68}	23'4" {7.12}	24'7" {7.50}	27'7" {8.41}
h - Min. swing radius		17'3" {5.27}	16'10" {5.14}	17'1" {5.20}	17'5" {5.30}
i - Horizontal digging stroke at ground level		17'1" {5.21}	20'0" {6.10}	23'2" {7.07}	27'2" {8.28}
j - Digging depth for 8 feet flat bottom		23'8" {7.21}	25'2" {7.67}	27'2" {8.27}	30'0" {9.15}
Bucket capacity SAE heaped cu.yd.{m³}		2.75 {2.10}	2.49 {1.90}	2.09 {1.6}	1.77 {1.35}

Unit: ft-in{m}

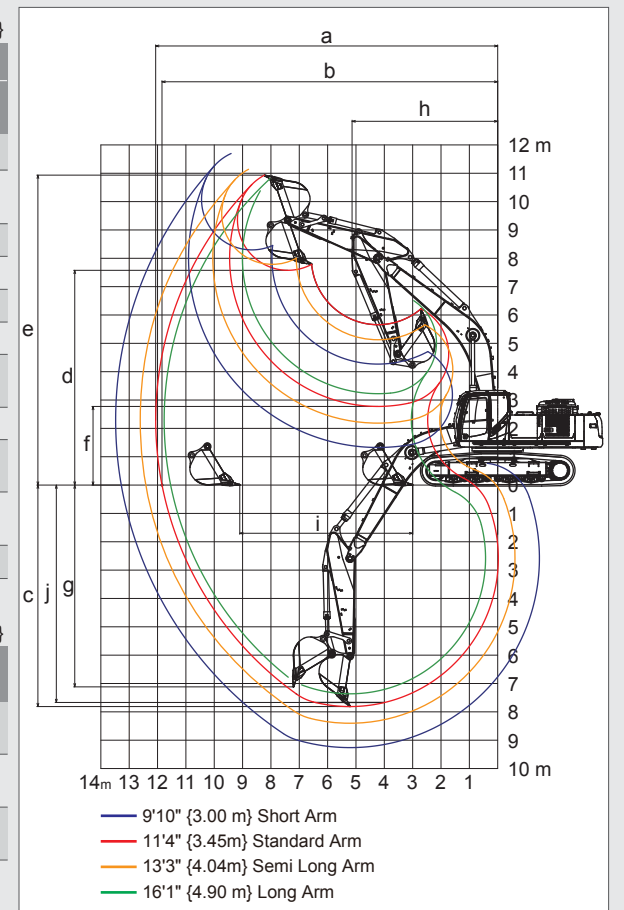

Digging Force

Arm length		Unit: lbs {kN}			
		Short 9'10" {3.00m}	Standard 11'4" {3.45m}	Semi Long 13'3" {4.04m}	Long 16'1" {4.90m}
Bucket digging force	SAE	52,400 {233}	52,600 {234}	52,600 {234}	52,400 {233}
	ISO	57,400 {255}*	57,500 {256}*	57,500 {256}	57,400 {255}*
Arm crowding force	SAE	48,100 {214}	43,800 {195}	39,600 {176}	34,400 {153}
	ISO	52,600 {234}*	48,100 {214}*	43,200 {192}	37,600 {167}*
		65,500 {291}*	65,600 {292}*	65,000 {289}	64,800 {288}*
		54,900 {244}*	49,900 {222}*	44,300 {197}	38,700 {172}*

* Power Boost engaged.

Dimensions

Arm length	Short 9'10" {3.00m}	Standard 11'4" {3.45m}	Semi Long 13'3" {4.04m}	Long 16'1" {4.90m}
A Overall length	39'8" {12,100}	39'6" {12,040}	39'8" {12,090}	39'10" {12,130}
B Overall height (to top of boom)	12'4" {3,750}	11'9" {3,570}	12'2" {3,720}	14'4" {4,360}
C Overall width	11'11.5" {3,650}**			
D Overall height (to top of cab)	11'1" {3,370}			
E Ground clearance of rear end*	4'5" {1,340}			
F Ground clearance*	20.1" {510}			

Unit: ft-in{mm}	
G Tail swing radius	12'3" {3,740}
G' Distance from center of swing to rear end	12'2" {3,700}
H Tumbler distance	14'5" {4,400}
I Overall length of crawler	17'11" {5,450}
J Track gauge	9'0" {2,750}
K Shoe width	35.4" {900}
L Overall width of upperstructure (With Catwalk / Without Catwalk)	11'5" {3,470} / 9'9" {2,980}

* Without including height of shoe lug
** Shoe width : 35.4" {900mm}

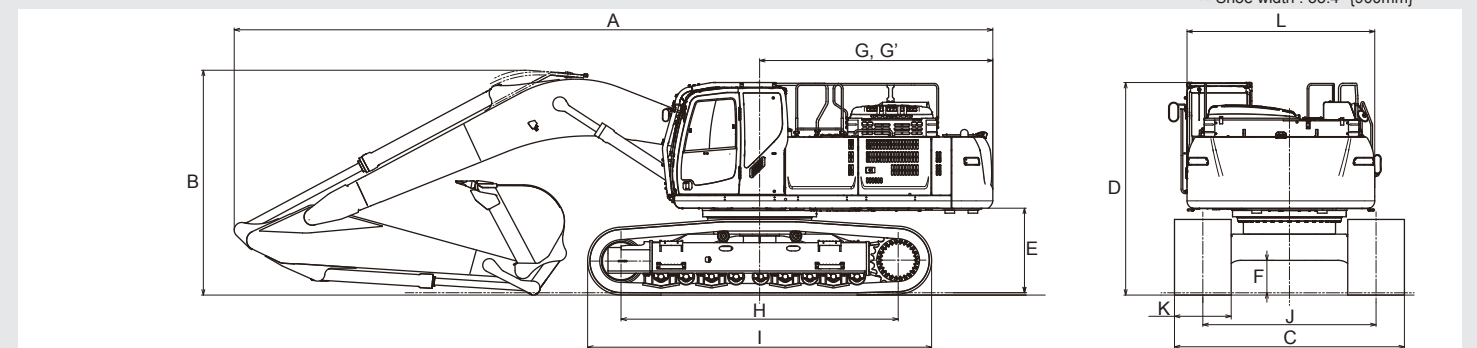

Operating Weight & Ground Pressure

In standard trim, with standard boom, 11'4" {3.45 m} arm, and 2.49cu yd {1.90 m³} SAE heaped bucket

Shaped	Triple grouser shoes (even height)	
Shoe width	ft-in{mm}	35.4" {900}
Overall width of crawler	ft-in{mm}	11'11.5" {3,650}
Ground pressure	psi {kPa}	8.4 {58}
Operating weight	lbs {kg}	111,400 {50,500}

