

## Standard and Optional Equipment

●=Std ○=Opt — = N/A

Category	Description	SK850LC-11
		Standard
Engine	ISUZU 6WG1 (Tier IV Final certified)	●
	Auto engine acceleration/deceleration	●
	Auto Idle Stop	●
Hydraulic system	3 work modes H, S, Eco	●
	Boom to arm regeneration	●
	Auto warm-up system	●
	Bi-direction (proportional hand control) and single-direction auxiliary hydraulics (nibbler and breaker)	●
	Rotation hydraulics with proportional hand control	●
	Hydraulic oil VG46	●
Piping	Rotation & N&B piping	●
	QH piping	●
Cabin	Air suspension seat with heating	●
	10-inch colour monitor	●
	LED door light	●
	Air-conditioner	●
	Radio (AM/FM, AUX, USB, Bluetooth® and hands-free telephone)	●
	12V power outlet	●
Lights	LED work lights ; 2 on boom, 1 on upper frame, 4 on rear counterweight, 1 on under cab	●
	LED work lights ; 2 on cab top front	○
Working equipment	Standard HD boom 27'1" {8.25 m}	●
	Standard HD arm 11'10" {3.60 m}	●
	Semi Long HD arm 14'5" {4.40 m}	○
	Long HD arm 17'9" {5.40 m}	○
Counterweight	Heavier C/W 36,160 lb {16,400 kg} with swing flashers	●
	Removable Counterweight	○
Undercarriage	25.6" {650 mm} double grouser shoe	○
	29.5" {750 mm} double grouser shoe	○
	35.4" {900 mm} double grouser shoe	●
Safety	Lower swivel guard	●
	Engine emergency stop switch	●
	Tilt opening top cab guard (Top guard level II ISO 10262:1998)	●
	Bar-type front guard (Front guard level II ISO 10262:1998)	○
	3-inch retractable seat belt	●
	Seatbelt indicator on display	●
	Travel alarm	●
	Swing flashers in counterweight	●
	Left and right side mirrors	●
	3-side 270-degree camera system	●
Others	Angled upper deck guards	●
	Catwalk	●
	Reversible Fan	●
	Machine Guidance ready brackets	●
	Quick coupler piping	●
	ISO to BHL pattern changer	●
	Battery disconnect switch	●
	KOMEXS Machine Monitoring	●
	4 Year or 4,000 Hour Warranty	●
	Single pedal travel	●
	K-load weighing system	●

Note: Bluetooth® is a registered trademark of the Bluetooth SIG Inc.

Note: This catalog may contain attachments and optional equipment that are not available in your area. And it may contain photographs of machines with specifications that differ from those of machines sold in your areas. Please consult your nearest KOBELCO distributor for those items you require. Due to our policy of continuous product improvements all designs and specifications are subject to change without advance notice.

Copyright by **KOBELCO CONSTRUCTION MACHINERY CO., LTD.** No part of this catalog may be reproduced in any manner without notice.

### KOBELCO CONSTRUCTION MACHINERY U.S.A. INC.

www.KOBELCO-USA.com



**KOBELCO** is the corporate mark used by Kobe Steel on a variety of products and in the names of a number of Kobe Steel Group companies.

Inquiries To:

Bulletin No. SK850LC-11\_NA\_2E\_2512

# KOBELCO

## Hydraulic Excavator

# -11 SERIES

# SK850LC

■ Engine Power:

512 hp {382 kW} @ 1,800 rpm  
(SAE NET)

■ Operating Weight:

190,700 lb {86,500 kg} - 192,300 lb {87,200 kg}



Complies with the  
latest exhaust  
emission regulations



US EPA  
Tier IV Final



# Performance Design

## PERFORMANCE BY DESIGN

The next generation of KOBELCO excavators brings together superior performance and thoughtful design like never before. Performance enhancements offer greater efficiency and productivity along with increased speed. Design improvements provide the ultimate in comfort and control.

KOBELCO refuses to compromise by creating machines that meet every challenge.

## EXCEPTIONAL PERFORMANCE JUST GOT EVEN BETTER

### Higher Efficiency, Plus a Tier IV Final Compliant Engine

Our Tier IV Final compliant engine is fitted with a diesel oxidation catalyst (DOC) and an SCR device to control emissions without using a diesel particulate filter (DPF). It has a large-capacity DEF tank, extending intervals between fill-ups.

Model: ISUZU 6WG1

### Engine Output

**512** hp {**382** kw}/**1,800** rpm (SAE NET)



### Bucket Digging Force

**90,600** lb {**403** kN}

(11'10" arm)

### Arm Digging Force

**69,900** lb {**311** kN}

(11'10" arm)

### Lifting Capacity

**66,010** lb  
{**29,940** kg}

(11'10" arm, ground level @ 20')

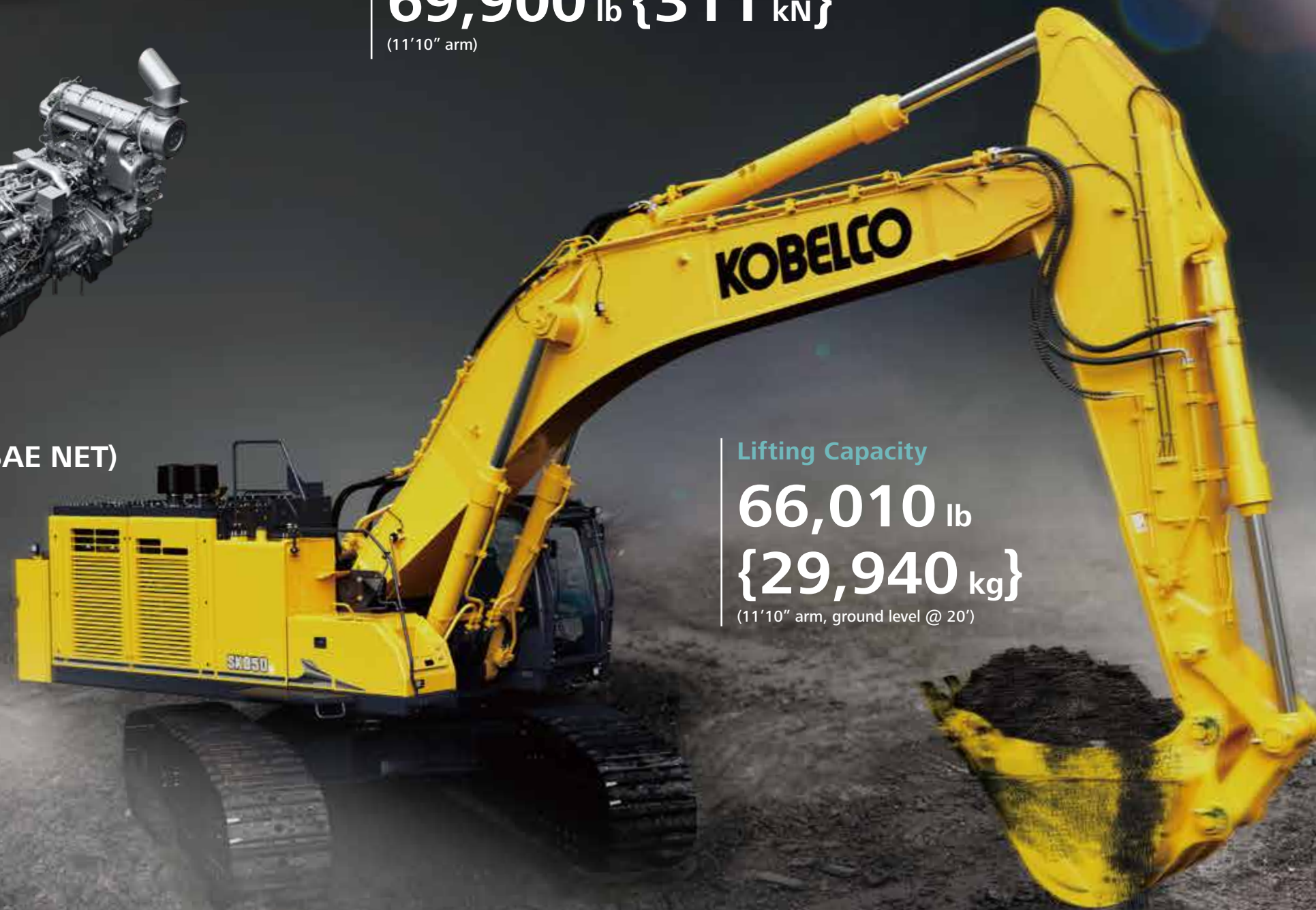



## SAFETY ON FULL DISPLAY

### Standard 3 Sides Safety Camera System

Our high-resolution, large display shows right, left and rear side cameras together. Multiple display allows the operator to customize viewing needs to enhance operator awareness and jobsite safety.



### Large 10-Inch Color Monitor

The easy-to-operate menu screen and recognizable icons assist the operator to select the most important information needed to ensure jobsite safety and machine control.



### Dial in the Right Information

Simply turn the jog dial to the right or left to select an operational feature, then press the dial to confirm selection.





## PREMIER OPERATOR COMFORTS

### Heated Air Ride Suspension Seat

A 7-way adjustable seat achieves excellent shock absorption and superior ride comfort.

### Multi Vent Air Conditioner

Cool air is blown from multiple outlets toward the operator's body for more comfortable operation.

### Ergonomic Lever Angles

Operators can move levers horizontally without twisting their wrists, reducing fatigue.



### Adjustable Height Joysticks

Joystick height is manually adjustable to suit operator's preference.

### LED Interior Light

Interior lights turn on and off automatically when the door is open or the ignition is turned to the OFF position. This ensures safe entry and exit in the dark.

### Tilting Left Side Console

Flip-up left console with integrated pilot control lock lever tilts for easy entry and exit from the cab.



## THE ULTIMATE IN SIMPLE DESIGN

In our pursuit of functional beauty and styling, we created an all new interior design focused with the operator in mind.

### Jog Dial

This dial integrates multiple functions into a single, easy to use interface. Even with gloves on, the operator can make the adjustments they need.

### LED Illumination

Dials and buttons are now backlit to provide a bright, clear view in any lighting condition.



# POWER PLANT DURABILITY YOU CAN TRUST

## Enhanced body rigidity for 85-ton class machines

The SK850LC machines are widely used in mid-scale construction projects and harsh worksites. The components have been reviewed and improvements have been made to their durability to ensure stable performance in such environments.

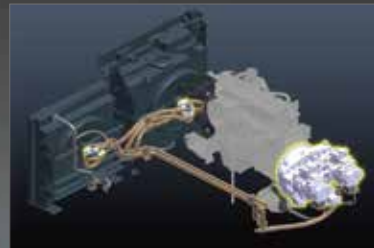

### Hydraulic drive cooling fan

Hydraulic drive optimises the cooling fan rotation speed to improve fuel economy and reduce noise. Also, the independent oil cooler fan better matches cooling to the hydraulic oil temperature, for optimal oil temperature control.



### Three track guides per side

Three heavy duty track guides installed on each side assure stability in the most demanding situations.



### Variable Gauge Crawler

The variable gauge crawler extends the crawlers for extremely stable operation, and retracts them for easier transport.

# CONVENIENT AND SENSIBLE EQUIPMENT



Rear camera



Right camera



Left camera

### Standard Rear, Left and Right Side Cameras



### Swing Flashers for a Safer Jobsite

Standard swing flashers notify ground workers that the machine is swinging.



### Single Pedal Travel



2 on boom (Left & Right)



4 on counter weight (Rear & Left & Right)



1 on upper frame



2 on cab top front (optional)

### Standard 7 LED Lights

Bright LED lights ensure visibility even during night work.



### Vertical Bar Front Cab Guard (optional)

\*The guard in the image is a vertical bar front cab guard specification.



### Quick Coupler Piping Brackets



Arm



Boom



Bucket link



Counterweight

### Machine Guidance Ready Brackets

Pre-welded brackets for quicker and easier installation of Machine Guidance Systems.



### Counterweight Removal System (Optional)

With less weight during transport, counterweight removal and installation is a safe, one-person job, saving labor and crane rental costs.



\*The image of SK520LC-11 is included as an image.



### Adjustable Height Joystick Consoles

The operator can adjust height of attachment control levers.



### Hands-Free Bluetooth® Phone Calls



### USB Charging Port / 12V Power Outlet



### Smartphone Holder

Includes USB port for charging.

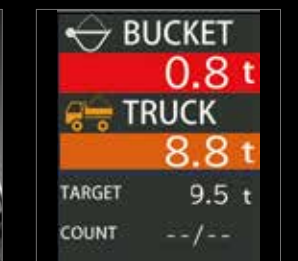

### K-LOAD (Load Weighing Function)

Weighing is possible while lifting and swinging, greatly improving work efficiency.  
\*Not legal for trade.

# GREATER MULTI-FUNCTION CAPABILITIES

## Attachment mode selection

The auxiliary flow rates for the bucket, breaker, nibbler, and rotating are all now adjustable by the operator through the monitor, allowing you to change tools quickly and easily. Mode settings for other attachments like the tilt rotator can be added or changed.



## Drain Piping

Quick hitch and Drain piping are available at the same time, expanding the variation of attachment.

# EASY MAINTENANCE

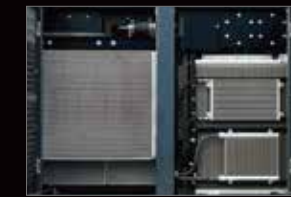

## Cooling system components



## Reversible fan

With the flip of a switch from the drivers seat, the standard feature reversing fan pulls air in the opposite direction, blowing debris away to prevent clogging.



## Auto-Coil Grease Gun Holder

Grease tank / Lubrication hose



## DEF/AdBlue® Tank



## Standard Overhead Top Guard Level II

The standard overhead cab guard can be tilted open for easy window cleaning.



## Pre air cleaner



## Air cleaner



## Engine maintenance



## Standard Left and Right Walkways

The left walkway provides easy access to the upper structure without having to go down to the ground. The right walkway supports refueling easier.



## Engine Oil Filter



## Fuel Filter



## Drain Filter



## Pre-Filter with Integrated Water Separator

Note: AdBlue® is a registered trademark of the Verband der Automobilindustrie e.V. (VDA).



# KOBELCO MONITORING EXCAVATOR SYSTEM



## Remote Monitoring for Peace of Mind

KOMEXS (Kobelco Monitoring Excavator System) uses satellite communication and internet to relay data, and therefore can be deployed in areas where other forms of communication are difficult. When a hydraulic excavator is fitted with this system, data on the machine's operation, such as operating hours, location, fuel consumption, and maintenance status can be obtained remotely.

## Direct Access to Operational Status

### Location Data

• Accurate location data can be obtained even from sites where communications are difficult.

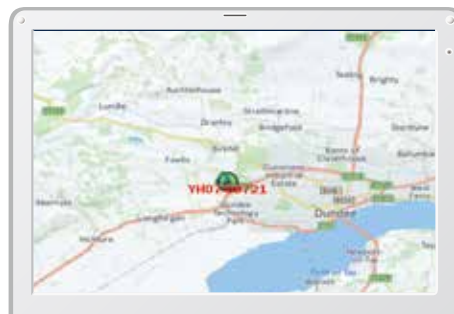

Latest location

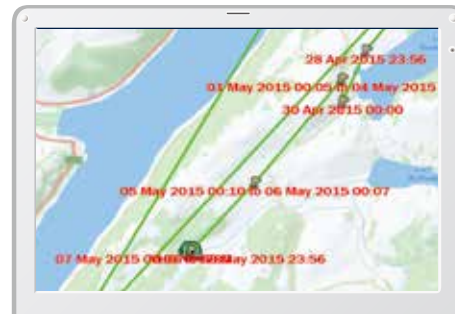

Location records



Work data

## Operating Hours

• A comparison of operating times of machines at multiple locations shows which locations are busier and more profitable.  
 • Operating hours on site can be accurately recorded, for running time calculations needed for rental machines, etc.

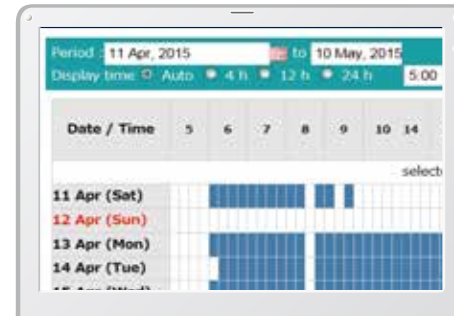

Daily report

## Fuel Consumption Data

• Data on fuel consumption and idling times can be used to indicate improvements in fuel consumption.

Work mode	Working Hrs	Total Fuel Consumption
H mode	2:06	24.5 L
S mode	0:00	0.0 L
E mode	169:19	1489.7 L
<b>TOTAL</b>	<b>171:25</b>	<b>1514.2 L</b>

Fuel consumption

## Graph of Work Content

• The graph shows how working hours are divided among different operating categories, including digging, idling, travelling and optional operations.



Work status

## Maintenance Data and Warning Alerts

### Machine Maintenance Data

• Provides maintenance status of separate machines operating at multiple sites.  
 • Maintenance data is also relayed to KOBELCO service personnel, for more efficient planning of periodic servicing.

Model	Serial No.	Hour Meter	Engine Oil
SK135SRLC-3/SK140SRL	YH07-09721	734 Hr	434
SK135SRLC-3/SK140SRL	YH07-09789	73 Hr	429
SK210LC-9	Y013-10454	960 Hr	58
SK210LC-9	Y013-10481	549 Hr	498
SK75SR-	YT08-30374		

Maintenance

### Warning Alerts

• This system warns an alert if an anomaly is sensed, preventing damage that could result in machine downtime.

## Alarm Information Can Be Received through E-mail

• Alarm information or maintenance notice can be received through E-mail, using a computer or cell phone.



Alarm messages can be received on mobile device.

## Daily/Monthly Reports

• Operational data downloaded onto a computer helps in formulating daily and monthly reports.

## Security System

### Engine Start Alarm

• The system can be set an alarm if the machine is operated outside designated time.



Engine start alarm outside prescribed work time

### Area Alarm

• It can be set an alarm if the machine is moved out of its designated area to another location.



Alarm for outside of reset area

# Specifications

## Engine

Model	ISUZU 6WG1
Type	Direct injection, water-cooled, 4-cycle diesel engine with turbocharger, intercooler, Tier IV Final certified
No. of cylinders	6
Bore and stroke	5.8" x 6.1" {147 mm x 154 mm}
Displacement	956.9 cu.in {15.681 L}
Rated power output	512 hp {382 kW} /1,800 rpm (Without fan)
Max. torque	1,620 lb-ft {2,200 N·m} /1,450 rpm (Without fan)

## Hydraulic System

Pump	
Type	Two variable displacement pumps + OPT gear pump+pilot gear pump
Max. discharge flow	2 x 133 US.gal {504 L/min} 1 x 13.0 US.gal {49.3 L/min} 1 x 7.92 US.gal {30 L/min}
Relief valve setting	
Boom, arm and bucket	4,790 psi {33.0 MPa}
Travel circuit	4,790 psi {33.0 MPa}
Swing circuit	3,770 psi {26.0 MPa}
Control circuit	725 psi {5.0 MPa}
Pilot control pump	Gear type
Main control valve	8-spool
Oil cooler	Air cooled type

## Swing System

Swing motor	Axial piston motor
Brake	Hydraulic; locking automatically when the swing control lever is in neutral position
Parking brake	Oil disc brake, hydraulic operated automatically
Swing speed	7.3 rpm
Swing torque	197,200 lb-ft {268 kN·m}

## Travel System

Travel motors	2 x axial-piston, two-step motors
Travel brakes	Hydraulic brake per motor
Parking brakes	Oil disc brake per motor
Travel shoes	51 each side
Travel speed	2.6 / 1.6 mph {4.2 / 2.6 km/h}
Drawbar pulling force	152,400 lb {678 kN}
Gradeability	70% {35°}

## Cab and control

Cab	All-weather, sound-suppressed steel cab mounted on silicon-sealed viscous mounts and equipped with a heavy, insulated floor mat.
Control	Two hand levers and two foot pedals for travel Two hand levers for excavating and swing Electric rotary-type engine throttle

## Cylinders

Boom cylinders	8.3" {210 mm} x 5'11" {1,800 mm}
Arm cylinder	8.7" {220 mm} x 7'2" {2,175 mm}
Bucket cylinder	7.9" {200 mm} x 5'2" {1,570 mm}

## Refilling Capacities and Lubrications

Fuel tank	253.6 U.S.gal {960 L}
Cooling system	24.0 U.S.gal {91 L}
Engine oil	14.3 U.S.gal {54 L}
Travel reduction gear	2 x 5.8 U.S.gal {22 L}
Swing reduction gear	2 x 2.1 U.S.gal {8 L}
Hydraulic oil tank	137.9 U.S.gal {522 L} tank oil level
	239.1 U.S.gal {905 L} hydraulic system
DEF/Urea tank	21.9 U.S.gal {83 L}

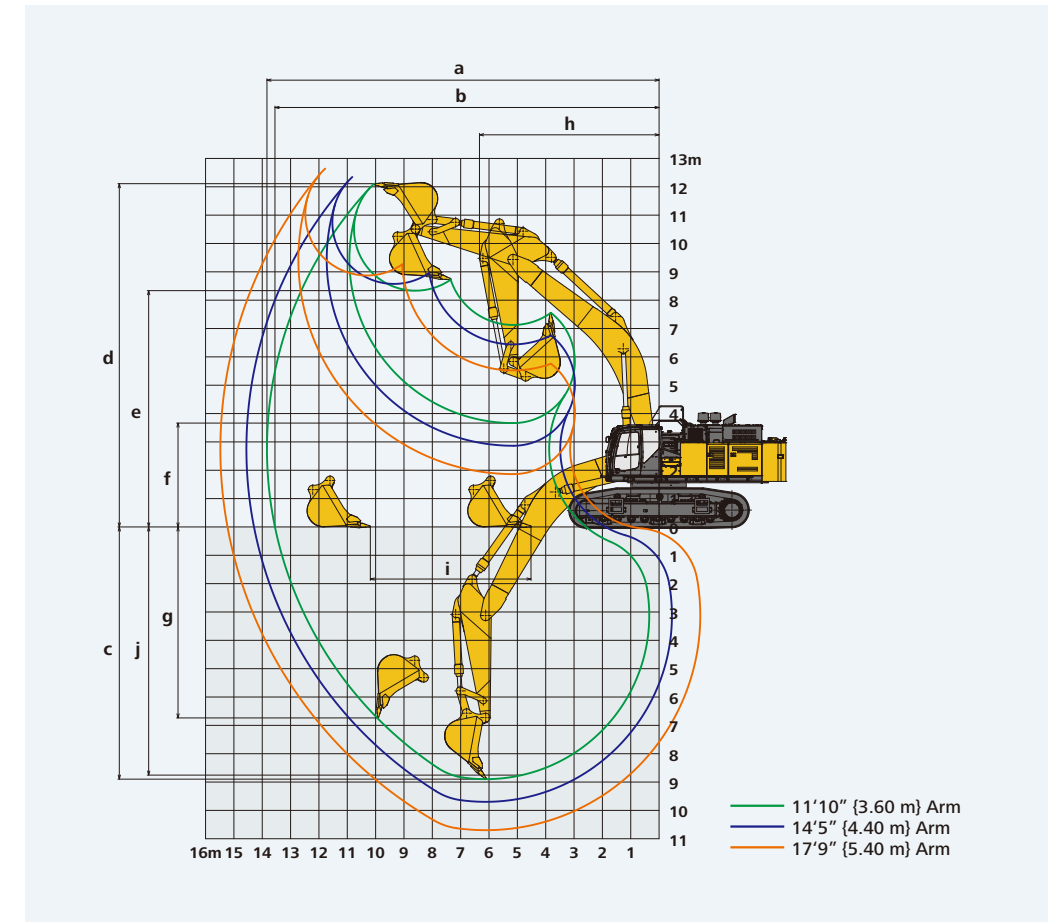

## Working Ranges

Unit: ft-in {m}

Boom	27'1" {8.25 m}			
Range	Arm	11'10" {3.60 m}	14'5" {4.40 m}	17'9" {5.40 m}
a- Max. digging reach		45'4" {13.83}	47'9" {14.56}	50'9" {15.48}
b- Max. digging reach at ground level		44'5" {13.55}	46'11" {14.29}	50'0" {15.23}
c- Max. digging depth*		29'2" {8.90}	31'10" {9.70}	35'1" {10.70}
d- Max. digging height*		39'9" {12.11}	40'6" {12.35}	41'6" {12.64}
e- Max. dumping clearance*		27'4" {8.34}	28'1" {8.57}	29'1" {8.87}
f- Min. dumping clearance*		12'0" {3.66}	9'5" {2.86}	6'1" {1.86}
g- Max. vertical wall digging depth*		22'1" {6.74}	24'6" {7.48}	27'7" {8.41}
h- Min. swing radius		20'10" {6.34}	20'10" {6.34}	21'0" {6.40}
i- Horizontal digging stroke at ground level		18'7" {5.67}	22'4" {6.80}	26'6" {8.08}
j- Digging depth for 2.4 m (8') flat bottom*		28'8" {8.75}	31'5" {9.58}	34'9" {10.60}
Bucket capacity SAE heaped cu yd {m³}		4.58 {3.5}	3.66 {2.8}	3.01 {2.3}

\* Without including height of shoe lug

## Digging Force (ISO 6015)

Unit: lb {kN}

Boom	27'1" {8.25 m}			
Arm length		11'10" {3.60 m}	14'5" {4.40 m}	17'9" {5.40 m}
Bucket digging force	SAE	79,600 {354}	79,600 {354}	79,600 {354}
	ISO	90,600 {403}	90,600 {403}	90,600 {403}
Arm crowding force	SAE	67,400 {300}	59,100 {263}	51,300 {228}
	ISO	69,900 {311}	61,100 {272}	52,600 {234}

# Specifications

## Operating Weight & Ground Pressure

In standard trim, with 27'1" {8.25 m} standard HD boom, 11'10" {3.60 m} arm, 4.58 cu yd {3.5 m<sup>3</sup>} ISO heaped bucket and heavier counterweight

Shaped		Double grouser shoes (even height)	
Shoe width	ft-in {mm}	35.4 {900}	
Overall width of crawler (Opened / retracted)	ft-in {mm}	14'7" {4,450} / 12'6" {3,800}	
Ground pressure	psi {kPa}	12.3 {84.6}	
Operating weight	lb {kg}	190,700 {86,500}	

In standard trim, with 27'1" {8.25 m} standard HD boom, 14'5" {4.40 m} arm, 3.66 cu yd {2.8 m<sup>3</sup>} ISO heaped bucket and heavier counterweight

Shaped		Double grouser shoes (even height)	
Shoe width	ft-in {mm}	35.4 {900}	
Overall width of crawler (Opened / retracted)	ft-in {mm}	14'7" {4,450} / 12'6" {3,800}	
Ground pressure	psi {kPa}	12.3 {84.8}	
Operating weight	lb {kg}	191,200 {86,700}	

In standard trim, with 27'1" {8.25 m} standard HD boom, 17'9" {5.40 m} arm, 3.01 cu yd {2.3 m<sup>3</sup>} ISO heaped bucket and heavier counterweight

Shaped		Double grouser shoes (even height)	
Shoe width	ft-in {mm}	35.4 {900}	
Overall width of crawler (Opened / retracted)	ft-in {mm}	14'7" {4,450} / 12'6" {3,800}	
Ground pressure	psi {kPa}	12.4 {85.3}	
Operating weight	lb {kg}	192,300 {87,200}	

## Dimensions

Unit: ft-in {mm}

Boom		27'1" {8.25 m}		
Arm length		11'10" {3.60 m}	14'5" {4.40 m}	17'9" {5.40 m}
A	Overall length	47'8" {14,530}	47'6" {14,480}	46'8" {14,220}
B	Overall height (to top of boom)	15'9" {4,790}	16'11" {5,160}	18'10" {5,750}
C	Overall width	Extended	14'7" {4,450}	
		Retracted	12'6" {3,800}	
D	Overall height (to top of cab)	12'0" {3,660}		
D'	Overall height (to top of handrail)	14'2" {4,320}		
E	Ground clearance of rear end*	5'1" {1,560}		
F	Ground clearance*	33.5" {850}		
G	Tail swing radius	15'0" {4,580}		
G'	Distance from centre of swing to rear end	14'8" {4,480}		
H	Tumbler distance	16'10" {5,140}		
I	Overall length of crawler	20'11" {6,380}		
J	Track gauge	Extended	11'8" {3,550}	
		Retracted	9'6" {2,900}	
K	Shoe Width	35.4 {900}		
L	Overall width of upperstructure	13'8" {4,170}**		
L'	Overall width of upperstructure (walkway folded)	10'6" {3,190}		
M	Overall length of upperstructure	20'10" {6,350}***		

\* Without including height of shoe lug \*\*With catwalk \*\*\*With cab guard

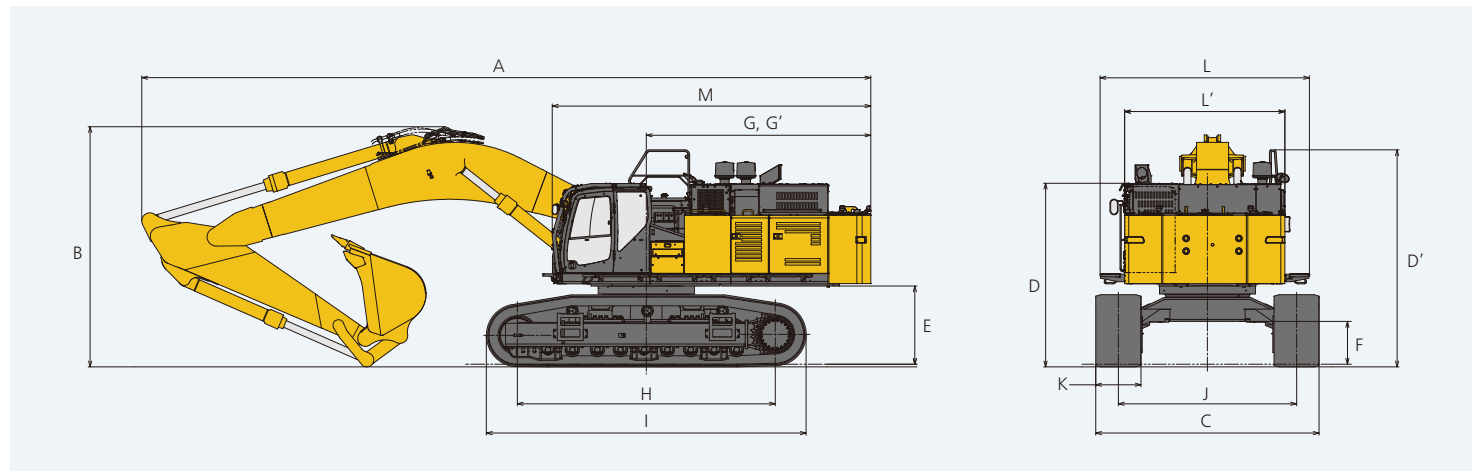

## Transportation

### Four Disassembly and Transport Patterns

The SK850LC can be disassembled and transported in four different ways, including: no counterweight, with boom attached; main body only; main body without crawler frame; etc.

Configuration	Description	Total weight
<b>Plan 1</b>		
	Upper structure without Counterweight	149,000 lb {67,500 kg}
	Undercarriage	
	27'1" {8.25 m} Boom	
	11'10" {3.60 m} Arm	
Width 12'6" {3,800 mm} (with 35.4" {900 mm} shoe)		
<b>Plan 2</b>		
	Upper structure without Counterweight	139,000 lb {62,900 kg}
	Undercarriage	
	27'1" {8.25 m} Boom	
	11'10" {3.60 m} Arm	
Width 12'6" {3,800 mm} (with 35.4" {900 mm} shoe)		

Heavier counterweight: 36,160 lb {16,400 kg} ○ : With – : Without

### Variable Gauge Crawler

The variable gauge crawler extends the crawlers for extremely stable operation, and retracts them for easier transport.

### Crawler Width

Shoe	35.4" {900 mm}
Extended	14'7" {4,450 mm}
Retracted	12'6" {3,800 mm}

Configuration	Description	Total weight
<b>Plan 3</b>		
	Upper structure without Counterweight	114,000 lb {51,900 kg}
	Undercarriage	
	27'1" {8.25 m} Boom	
	11'10" {3.60 m} Arm	
Width 12'6" {3,800 mm} (with 35.4" {900 mm} shoe)		
<b>Plan 4</b>		
	Upper structure without Counterweight	58,700 lb {26,600 kg}
	Undercarriage	
	27'1" {8.25 m} Boom	
	11'10" {3.60 m} Arm	
Width 10'6" {3,190 mm} Installation of a hoisting kit is required.		

Boom		
27'1" {8.25 m} Standard HD Boom		
Width: 4'4" {1,310 mm} Weight: 20,200 lb {9,160 kg}		
Arm		
11'10" {3.60 m}	14'5" {4.40 m}	17'9" {5.40 m}
Width: 31.1" {790 mm} Weight: 10,320 lb {4,680 kg}	Width: 31.1" {790 mm} Weight: 11,250 lb {5,100 kg}	Width: 31.1" {790 mm} Weight: 12,810 lb {5,810 kg}
Counterweight		
Heavier counterweight		
Width: 34.3" {870 mm} Weight: 36,160 lb {16,400 kg}		
Catwalk		
Catwalk (Front Left)	Catwalk (Left)	Catwalk (Front Right)
Hight: 7.68" {195 mm} Weight: 77 lb {35 kg}	Hight: 6.10" {155 mm} Weight: 198 lb (90 kg) (66 lb (30 kg) x 3)	Hight: 7.68" {195 mm} Weight: 77 lb {35 kg}

