

**LaBounty**<sup>®</sup>

[www.stanleyinfrastructure.com/brands/labounty](http://www.stanleyinfrastructure.com/brands/labounty)



**MSD**

**LEGEND SERIES SHEAR**

**SAFETY, OPERATION & MAINTENANCE**

516649 User Manual 3/2020 Ver. 6

# PREFACE

This manual contains information for the safe operation and maintenance of the LaBounty MSD Legend Series shear. Read the entire manual before the initial start-up of the attachment. It is important to know the correct operating procedures of the attachment and all safety precautions to prevent the possibility of property damage and personal injury.

The LaBounty attachment has been designed and manufactured with high quality materials and care in workmanship. The instructions in this manual have been prepared to ensure that, when followed properly, the attachment will provide efficient and reliable service. Continuing product development and improvement may have caused changes in the attachment that are not reflected in this manual. If a question arises regarding the operation or maintenance of the attachment, contact a LaBounty dealer for the most current information available.

## IMPORTANT

This operator's manual must accompany the attachment at all times and be readily available to the operator.

## MANUAL REPLACEMENT

Should this manual become damaged, lost or additional copies are required, immediately contact any authorized LaBounty dealer. You may also download a PDF copy at [www.stanleyinfrastructure.com](http://www.stanleyinfrastructure.com).

## REGISTRATION FORM

The Warranty Registration Form must be filled out by the dealer or customer and returned to LaBounty indicating the date the machine went into service.

## POSSIBLE VARIATIONS

LaBounty cannot anticipate every possible circumstance that might involve a potential hazard, as the owner's requirements and equipment may vary. Therefore, the warnings in this publication and on the product may not be all-inclusive and you must ensure that the procedure, application, work method and operating technique is safe for you, and others, before operation.

## PUBLIC NOTICE

LaBounty reserves the right to make changes and improvements to its products and technical literature at any time, without public notice or obligation. LaBounty also reserves the right to discontinue manufacturing any product at its discretion, at any time.



## WARRANTY

All work or repairs to be considered for warranty reimbursement must be authorized by the LaBounty Service Department before work is started. Any alterations, modifications or repairs performed before authorization by the LaBounty Service Department will render all warranty reimbursement consideration null and void without exception. Improper operation or improperly performed maintenance may render any warranty null and void.

# CONTENTS

<b>SAFETY .....</b>	<b>4</b>
<b>DECALS.....</b>	<b>6</b>
<b>TERMS .....</b>	<b>7</b>
<b>INSTALLATION.....</b>	<b>8</b>
Second Member Installation.....	8
Third Member Installation.....	8
Non-Rotating Installation.....	8
Hydraulic Installation.....	9
InSite™ Electrical Installation.....	10
Connect to Excavator DC Power.....	11
Connect to the Excavator Ignition Switch.....	11
InSite Power Cable Wiring Diagram.....	12
Download & Install the InSite Mobile Application.....	13
Removing the Shear from the Excavator.....	13
Storing the Shear.....	14
<b>OPERATION.....</b>	<b>15</b>
Before You Start.....	15
Safety Devices.....	15
Technical Specifications.....	16
Controls.....	16
Operating Tips.....	17
Bleed the Shear Hydraulic Circuit.....	18
Bleed InSite.....	19
Check for Leaks.....	20
<b>MAINTENANCE .....</b>	<b>21</b>
8-Hour Inspection Checklist.....	21
80-Hour Inspection Checklist.....	22
1500-Hour Inspection Checklist.....	22
2,000- Hour Inspection Checklist.....	22
Hydraulic Inspection.....	23
Shear Lubrication.....	23
Planetary Gearbox Lubrication.....	24
Inspect / Torque Bolts.....	25
Blade Maintenance.....	26
Blade Removal.....	26
Measuring & Shimming Blade Gaps.....	28
Blade Rotation.....	31
Jaw Build Up & Hardsurfacing.....	38
Replace Wear Plates & Bars.....	41
Slide Screw Adjustment.....	41
Check the Cylinder Gap.....	42
Speed Valve.....	43
Speed Valve Assembly Illustrations.....	45
Hydraulic Schematics.....	49

# SAFETY

	The Safety Alert Symbol alerts you to potential personal injury hazards. Obey all safety messages that follow to avoid possible injury or death.
	Indicates an imminently hazardous situation which will result in death or serious injury.
	Indicates a potentially hazardous situation which could result in death or serious injury.
	Indicates hazards that could result in damage to the equipment or personal injury.
	Indicates important procedures.



Your safety and the safety of others is a direct result of how you operate and maintain your equipment. Read and understand this manual and other safety information provided with the base machine and be sure that you understand all controls and operating

instructions before attempting to operate this equipment. Failure to follow the safety precautions can result in personal injury, death or property damage.

Carefully read all safety messages in this manual and on your equipment safety signs. Keep safety signs in good condition. Replace missing or damaged safety signs.

Because LaBounty cannot foresee all hazardous circumstances, the precautions listed in this manual and on the equipment are not all-inclusive. If a procedure, method, tool or part is not specifically recommended by LaBounty, determine whether it is safe for you and others, and that the equipment will not be damaged or made unsafe as a result of your decision to implement it.

The basic rules are summarized in this section of the manual. They also appear throughout the manual along with additional specific rules for safety and operation.

## GENERAL

- If the attachment is not functioning properly, shut down the machine, follow proper Lock-out / Tag-out

- procedures and follow proper repair procedures.
- Remove and replace any damaged or worn parts with parts recommended by LaBounty. Use of parts that are not factory approved may cause damage or unnecessary downtime and may void the warranty.
- NEVER operate equipment without the original safety guards in place.
- DO NOT process material with the attachment over the operator's cab. Doing so will result in severe personal injury or death from falling debris.
- DO NOT attempt to process brittle materials, such as axles and railroad rail. DO NOT process any material in a position that may propel it toward the operator, other workers, buildings or equipment.
- Clear all persons and equipment from the area of operation and machine movement. NEVER move loads over people or equipment. When viewing the operation of the attachment, maintain a safe distance of at least 75 feet (23 meters).
- NEVER approach power lines with any part of the machine. Keep clear at a minimum of 15 feet (5 meters).
- DO NOT close the attachment on a structure and reverse the excavator in an attempt to pull down material.
- Use of this tool on certain materials could generate dust potentially containing a variety of hazardous substances, such as, asbestos, silica or lead. Inhalation of dust containing these, or other hazardous substances could result in serious injury, cancer or death. Protect yourself and those around

you. Research and understand the materials you are processing. Follow safety procedures and comply with all applicable national, state or provisional health and safety regulations relating to them. If appropriate, arrange for the safe disposal of the materials by a qualified person.

- Disassembly of any pin-connected attachment can be hazardous. NEVER remove any pin unless the attachment is on the ground and blocked up. Serious injury or death could result. Metal chips or debris may fly when a connecting pin is struck. Use a brass drift when striking pins and always wear protective clothing and proper eye protection. Pins may fly when struck with force to drive them in or out. Always keep people clear when removing or installing pins.
- Do not operate this, or any other equipment, under the influence of drugs or alcohol.
- DO NOT modify LaBounty equipment without factory authorization. This equipment is designed to do a specific job and alterations could result in injury.
- ALWAYS lower the boom to the ground before leaving the cab. If it is necessary to work on an attachment off the ground, securely support the machine and attachment. DO NOT support the machine on cinder blocks, hollow tiles or props that may crumble under continuous load. DO NOT rely on a cylinder to hold the attachment in the air. If a control is moved or hydraulic pressure is otherwise released, the attachment may drop. DO NOT work under a machine that is supported only by a jack.
- DO NOT weld on any structural member unless specifically authorized by LaBounty. Unauthorized welding will void the warranty, may cause structural failure and could result in personal injury.
- Keep clear of potential pinch points, including the moving upper jaw, cylinder connections, bucket linkages and other moving parts.
- Before operating the attachment, read and observe all safety instructions in the Operation & Maintenance manual. If you are unfamiliar with any operation or maintenance procedure, seek instruction before proceeding.
- Inspect the attachment daily. Do not operate a poorly maintained or damaged attachment.
- Never operate a machine if an unsafe condition exists. Attach a "Do Not Operate" tag to the machine.

## BASE MACHINE

- Ensure that the cab is equipped with the proper safety guards for LaBounty applications. The cab MUST be equipped with an approved Falling Object Protection Structure (FOPS) and cab guarding. The FOPS must meet the requirements of SAE standard J1356. A transparent, shatter-resistant shield covering the front of the cab, is also required. Contact your base machine equipment dealer or manufacturer for

more information on the availability of FOPS and cab guarding. Lack of proper FOPS and guards may result in injury or death.

- Avoid tipping. The attachment will alter the lift capacities of the base machine. DO NOT overload the excavator or serious injury could result. Lift capacities will vary if the base machine is not on level ground. Lifting incorrectly can cause severe injury or machine damage. Use the recommended excavator counterweight. Use short slings and lift the load only as high as necessary.
- DO NOT allow riders on the machine. Riders are subject to serious injuries, such as being struck by foreign objects or being thrown off the machine. Riders also distract and obstruct the operator, resulting in the machine being operated in an unsafe manner. NEVER use the attachment as a work platform or personnel carrier.
- Check ground conditions before operating. Avoid unstable or slippery areas and position the base machine on firm, level ground. If level ground is not possible, position the base machine to use the attachment to the front or back of the carrier. Avoid working over the side of the base machine.

## HYDRAULIC

- Hydraulic oil becomes hot during operation. DO NOT come in contact with hot hydraulic oil as it could cause severe burns. Wear adequate protective clothing and safety equipment.
- DO NOT tamper with hydraulic lines or components while they are pressurized. Escaping fluid under pressure can penetrate the skin, causing serious injury. Keep hands and body away from pinholes and nozzles which eject fluids under high pressure. Use a piece of cardboard to search for leaks. If ANY fluid is injected into the skin, seek immediate medical assistance.

## PPE

- ALWAYS wear close-fitting clothing and safety equipment appropriate to the job. Safety equipment should be worn at all times when viewing, operating or maintaining the attachment. Safety equipment includes eye protection, hard hat, steel toe shoes, gloves, hearing protection and respirator.

# DECALS



Pressure Relief Decal  
512572  
**FIGURE 1**

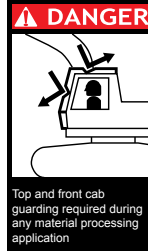

Cab Safety Decal  
503647  
**FIGURE 6**



Cylinder Bleed Decal  
512554  
**FIGURE 7**



InSite Decal  
516648  
**FIGURE 8**

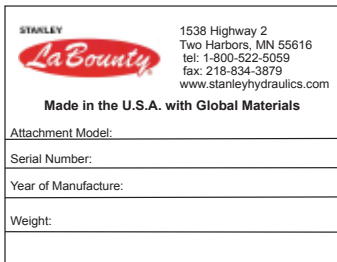

Model/Serial Number Plate  
511045  
**FIGURE 2**

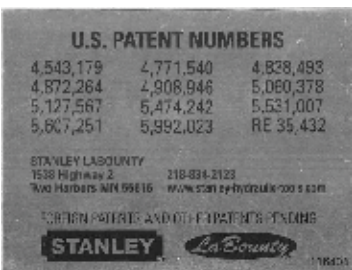

Patent Plate  
116404  
**FIGURE 3**



Safe Viewing Distance Decal  
116389 (13" x 30")  
503706 (6" x 13")  
**FIGURE 4**



Grease Decal  
116338  
(At each fitting)  
**FIGURE 5**

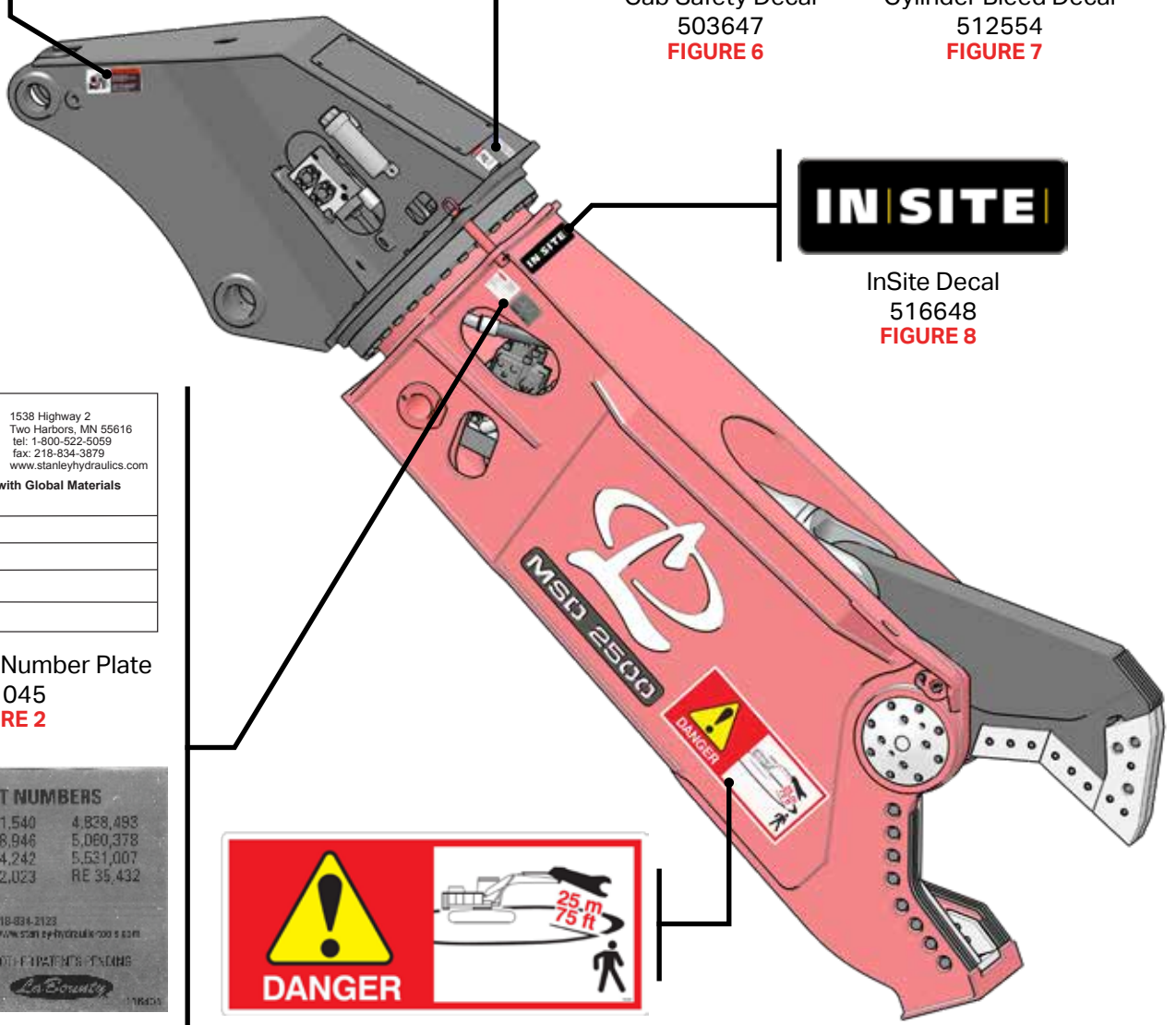

# TERMS

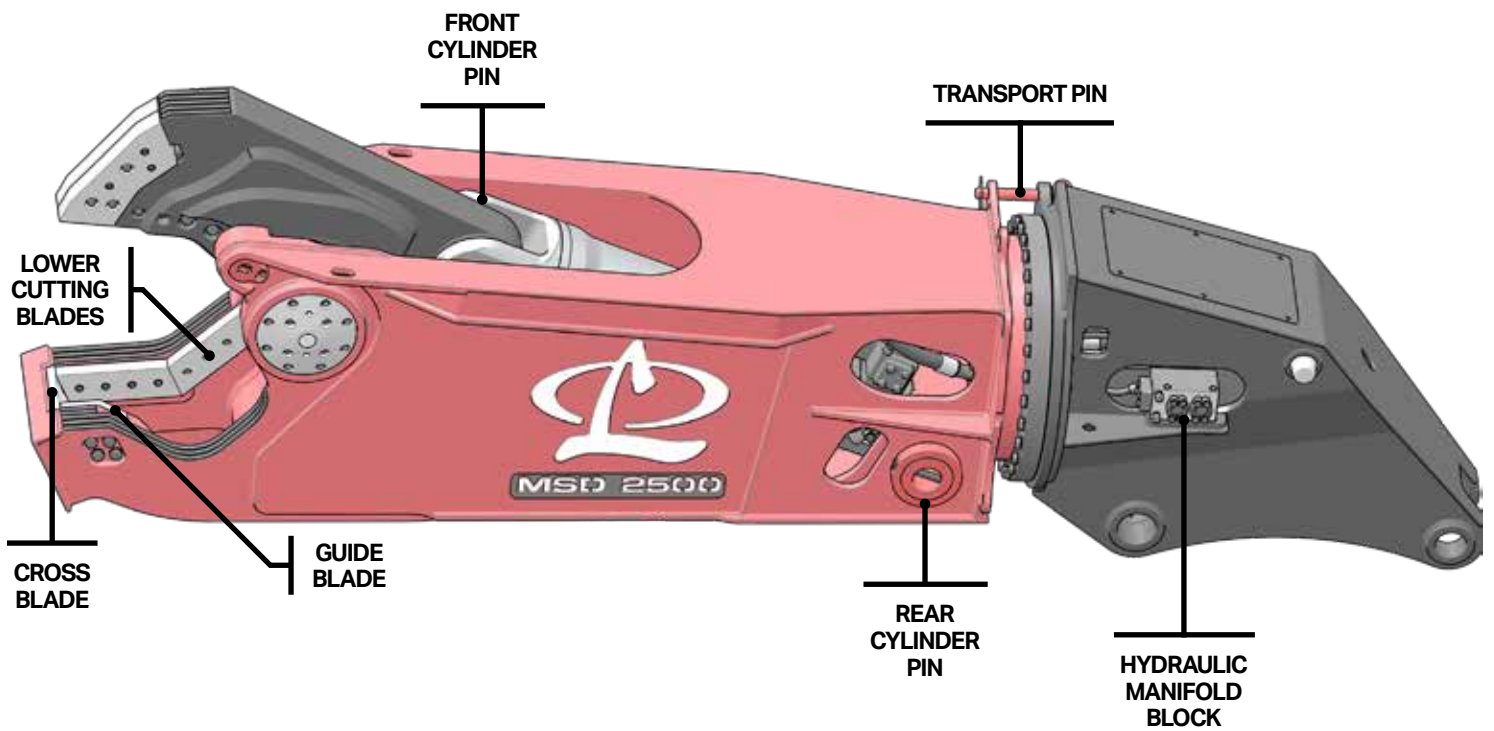
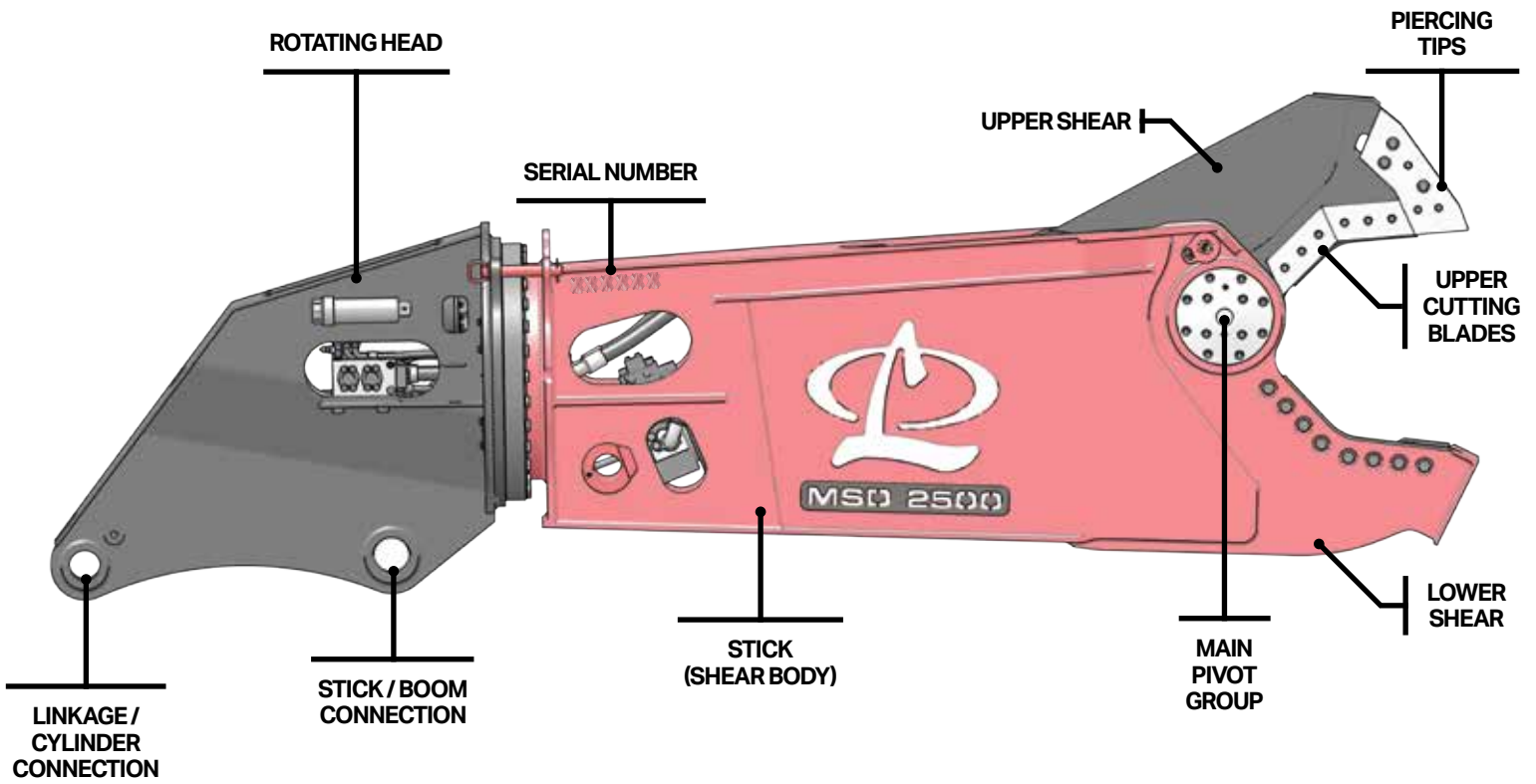

# INSTALLATION

1. Locate flat, hard ground (e.g. concrete floor).
2. Place the shear on the ground so the boom pivot is up. Use blocking to keep the shear stable and level.
3. Remove the excavator bucket. Follow the manufacturer's recommended procedure

**Note: Plug hydraulic hoses and lines to prevent contamination.**

## SECOND MEMBER INSTALLATION

**Note: A second member mount is where the shear replaces the excavator stick.**

1. Remove the excavator stick. Follow the manufacturer's recommended procedure.
2. Bring the excavator in position, carefully lining up the boom with the shear boom connection on the mounting bracket.

**Note: It may be necessary to lift the rear of the shear with a hoist or forklift, to allow the boom to connect to the bracket.**

3. Pin the excavator boom to the boom connection (See Figure 9).
4. Clear all personnel and instruct the excavator operator to slowly lift the shear so there will be enough clearance to pin the excavator cylinder to the cylinder connection.
5. Extend the arm cylinder rod and connect the cylinder to the cylinder connection using the cylinder connection pin.
6. If you have a rotating shear, remove the transport pin and place it in its stowed position (see Figure 12).

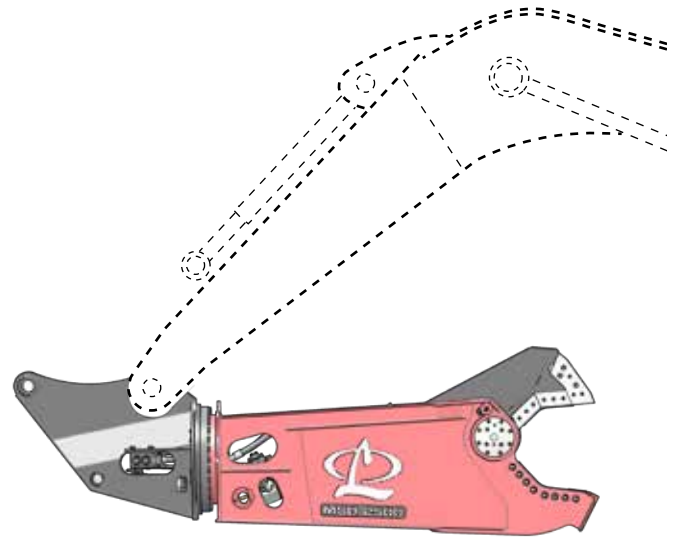

Second Member Installation  
**FIGURE 9**

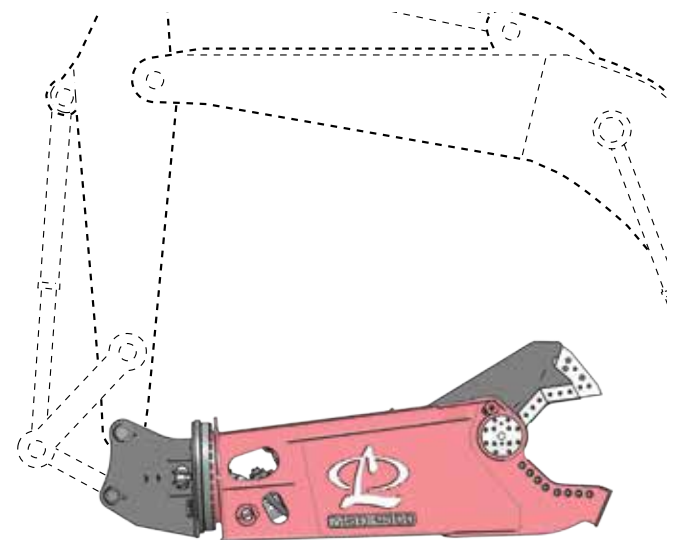

Third Member Installation  
**FIGURE 10**

## THIRD MEMBER INSTALLATION

**Note: A third member installation is where the shear replaces the excavator bucket.**

1. Bring the excavator in position, carefully lining up the stick tip with the stick connection on the mounting bracket.

**Note: It may be necessary to lift the rear of the shear with a hoist or forklift, to allow the stick to connect to the bracket.**

2. Pin the excavator stick to the stick connection.
3. Carefully extend the excavator bucket cylinder to move the bucket linkage. Position the link into the mounting bracket linkage connection.
4. Pin the linkage connection to the shear bracket.
5. Remove the transport pin and place it in its stowed position (see Figure 12).

## NON-ROTATING INSTALLATION

Care must be taken when unloading the shear. Place the shear on secure, stable blocking. Ensure the blocking will not allow the upper jaw move in any way or touch the ground.

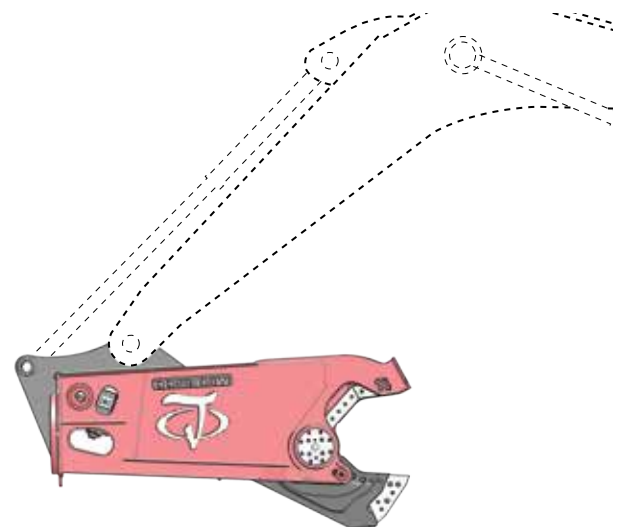

Non Rotating Installation  
**FIGURE 11**



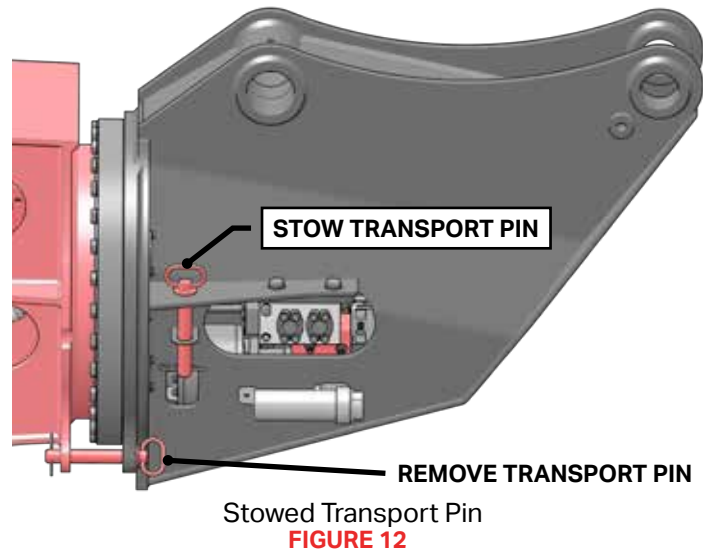

## HYDRAULIC INSTALLATION

Note: Refer to "Hydraulic Schematics" on page 49.



**Do not connect hydraulic lines while they are pressurized. Escaping fluid under pressure can penetrate the skin, causing serious injury.**

### Hydraulic Circuit Requirements

Note: Values given are standard values. For custom attachments reference the parts manual.

Model	Jaw Cycle Circuit (Max)	Rotation Circuit (Max)	Connection
MSD1000	80 GPM (300 LPM) 4000-5500 PSI (275-380 Bar)	3-4GPM (11-19 LPM)* 2000-2500 PSI (138-172 Bar)	Cylinder: 1 inch Code 62 Rotation: -8 FFORX
MSD1500	110 GPM (410 LPM) 4000-5500 PSI (275-380 Bar)		Cylinder: 1 inch Code 62 Rotation: -8 FFORX
MSD 2000	130 GPM (490 LPM) 4000-5500 PSI (275-380 Bar)	5-7 GPM (19-30 LPM)* 2000-2500 PSI (138-172 Bar)	Cylinder: 1.25 inch Code 62 Rotation: -8 FFORX
MSD 2250	135 GPM (511 LPM) 4000-5500 PSI (275-380 Bar)	8-10 GPM (30-42 LPM)* 2000-2500 PSI (138-172 Bar)	Cylinder: 1.25 inch Code 62 Rotation: -8 FFORX
MSD 2500	140 GPM (530 LPM) 4000-5500 PSI (275-380 Bar)	8-11 GPM (30-45 LPM)* 2000-2500 PSI (138-172 Bar)	Cylinder: 1.25 inch Code 62 Rotation: -8 FFORX
MSD 3000	150 GPM (560 LPM) 4000-5500 PSI (275-380 Bar)	8-11 GPM (30-45 LPM)* 2000-2500 PSI (138-172 Bar)	Cylinder: 1.25 inch Code 62 Rotation: -8 FFORX
MSD 4000	180 GPM (680 LPM) 4000-5500 PSI (275-380 Bar)		Cylinder: 1.25 inch Code 62 Rotation: -8 FFORX
MSD 4500	200 GPM (750 LPM) 4000-5500 PSI (275-380 Bar)		Cylinder: 1.5 inch Code 62 Rotation: -8 FFORX

\*Rotation flow specifications are an estimate. Adjust your specific flow so that the shear rotates at 3-6 RPM. Rotating faster than 3-6 RPM can cause rotation component damage.

1. Connect the hydraulic hose to the connections located on each side of the head.

**Note: Each port on the head is labeled so users can easily identify the cylinder, rotation and case drain ports.**

2. For rotating models, after installing the hydraulic circuits on the base machine, install additional hydraulic lines up the boom.

- Two 1/2" (13 mm) diameter feed lines

- One 1/2" (13 mm) diameter case drain
3. Install jump lines from each of these lines to the shear bulkhead or manifold fittings. Refer to the parts manual.
  4. Torque all hydraulic fittings to values shown in "Inspect / Torque Bolts" on page 25.

## **! WARNING**

**Do not check for hydraulic leaks with your hands. Hydraulic oil could inject into the skin. Seek immediate medical attention if an injection injury occurs.**

5. Visually check for hydraulic oil leaks or hydraulic hose interference.

**Note: The hydraulic circuit must be bled before putting the shear into service (see "Bleed the Shear Hydraulic Circuit" on page 18).**

## **INSITE™ ELECTRICAL INSTALLATION**

MSD Legend shears are equipped with InSite. InSite pulls information from the shear to provide performance metrics that help increase productivity and reduce downtime. InSite requires DC power from the excavator.

### **Run Power Cable Up the Excavator Boom**

## **! WARNING**

**Ensure all electrical power is turned off and the main battery disconnect switch is in the open position. Risk of electric shock. Perform Lock-Out / Tag-Out procedures on all electrical energy sources.**

InSite requires +12 VDC or +24 VDC from the excavator. The power supply cable will be fed to the excavator and connected to the main battery disconnect switch (or excavator fuse panel, if preferred) and to the keyed ignition switch.

1. Connect the short armored jump cable to the power cable receptacle on the InSite control box.

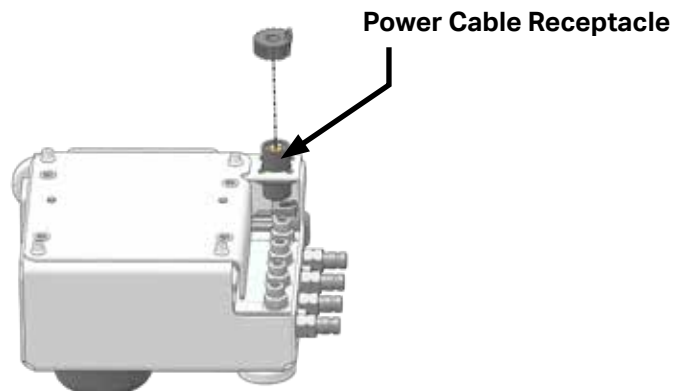

2. Connect the long InSite power supply cable to the jump cable.
3. Using the supplied zip ties, run the InSite power supply cable up the excavator boom and to the excavator. Secure the cable at least every 2 feet (610 mm) .
4. Ensure the power cable is not allowed to touch or rub objects that may damage the cable.
5. The end of the power supply cable will terminate in 3 bare wires.

## CONNECT TO EXCAVATOR DC POWER

6. Connect one 5A fuse holder to the white wire of the power supply cable.
7. Connect a length of 18 AWG wire from the terminal on the opposite end of the 5A fuse holder to the positive terminal of the excavators main battery disconnect switch.
8. Connect the green wire to chassis ground.

## CONNECT TO THE EXCAVATOR IGNITION SWITCH

**Note: InSite power is electrically connected to the excavator ignition switch. This doesn't mean you need to wire directly to the ignition switch. You may make this connection to any terminal that is electrically connected to the ignition switch, as long as InSite power will be OFF when the excavator key is removed.**

9. Connect one 5A fuse holder to the black wire.
10. Connect a length of 18 AWG wire from the terminal on the opposite end of the 5A fuse holder to the excavator ignition switch.

### Confirm InSite is Communicating

InSite has two LED's that we can use to confirm that the unit is working properly.



LED	Meaning
Solid Green	InSite is powered and connected via cellular.
Flashing Green	InSite is powered, but is searching for a cellular connection.
No Light	InSite is not powered. Check electrical connections.

# INSITE POWER CABLE WIRING DIAGRAM

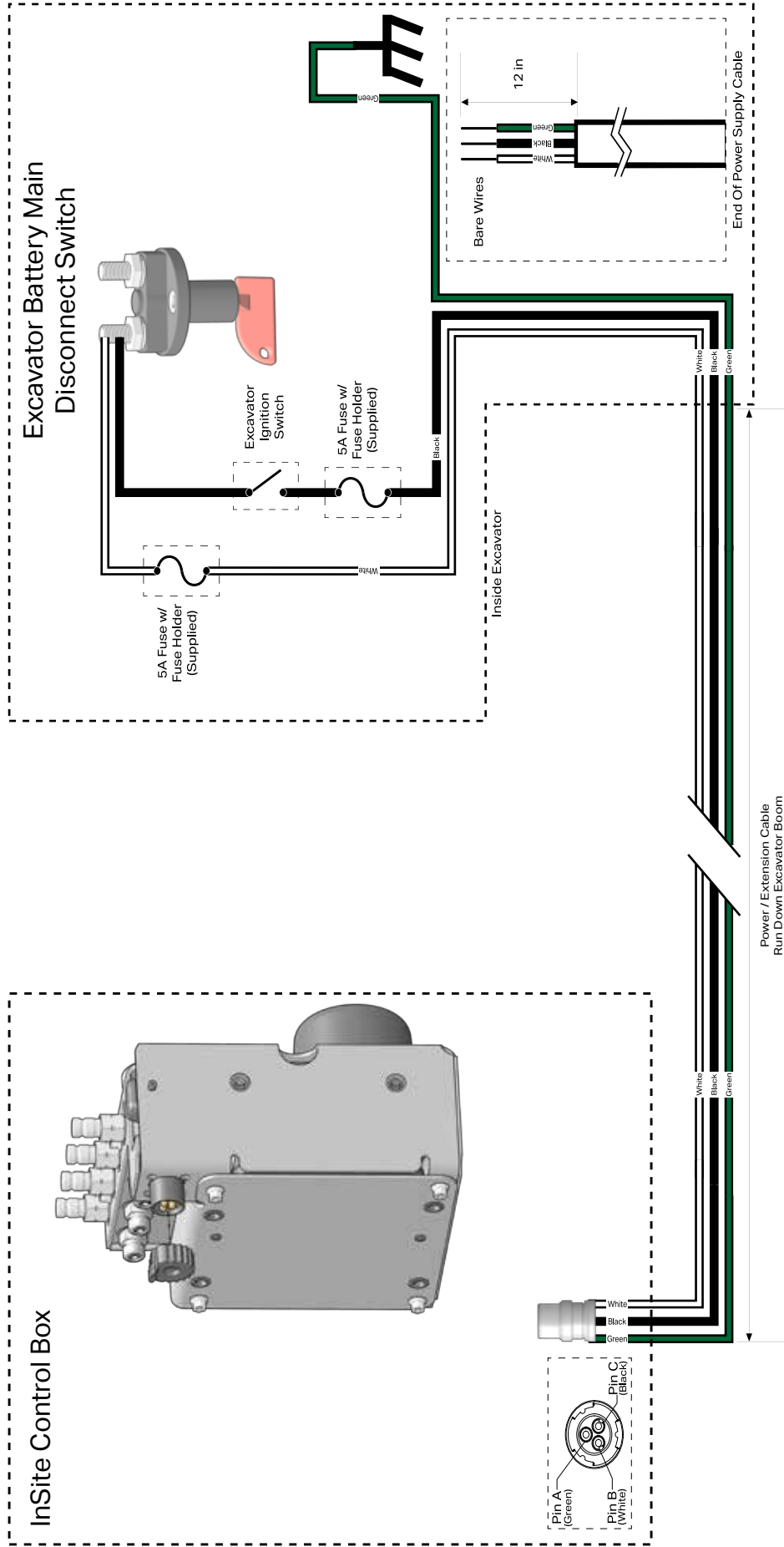

## DOWNLOAD & INSTALL THE INSITE MOBILE APPLICATION

InSite sends data about each of your InSite equipped LaBounty shears to a smart phone or mobile device.

1. Access the app store for your iPhone, iPad or Android device. Search for "InSiteProCall".
2. Install the InSite application.
3. Open the application and register a new InSite account, if you don't already have one.
4. Log in and accept the End User License Agreement.
5. Contact InSite service at (218) 834-6840 to obtain your equipment group code. The group code allows access to your data.

**Note: The InSite application is required to finalize installation and access shear data.**

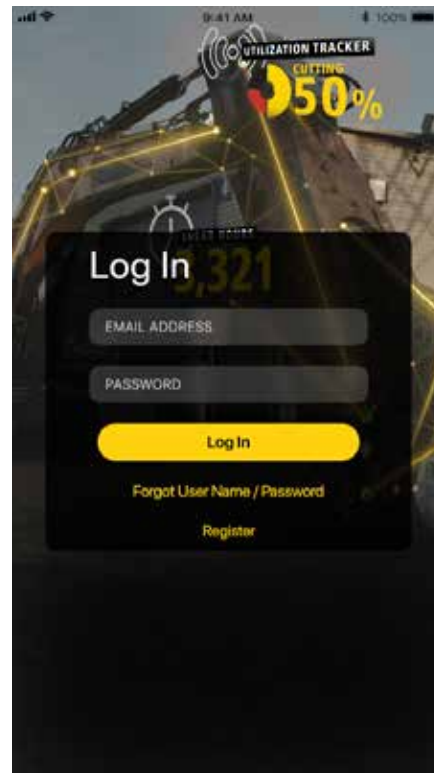

## REMOVING THE SHEAR FROM THE EXCAVATOR

1. Position the shear on the ground under the excavator boom, as far as the stick cylinder will extend.

**Note: Use blocking to support the stick cylinder from the excavator boom.**



**Disassembly of any pin-connected attachment can be hazardous. Never remove pins unless the attachment is on the ground and blocked up. Serious injury could result.**

2. Insert the transport pin between the rotating head and the shear.
3. Remove the stick cylinder pin from the shear mounting bracket.
4. Fully retract the stick cylinder.
5. Cycle the shear jaw closed.
6. Turn off the excavator and relieve any trapped pressure in the hydraulic system. Lock-out / Tag-out the hydraulic power source.

## **WARNING**

**Trapped hydraulic pressure may be present after the base machine is shut off. Extreme caution must be taken when removing hydraulic hoses or lines. Injury or death could result.**

7. Disconnect the hydraulic fittings. Plug the fittings, hoses and lines to prevent contamination of the hydraulic oil.
8. Ensure the shear is properly blocked-up and can receive the total weight of the shear.
9. Remove the boom pin from the shear.

### **STORING THE SHEAR**

1. Grease the shear, as described in "Shear Lubrication" on page 23.
2. Fully retract the shear cylinder.
3. Block the shear off the ground using wood blocking. Ensure the shear is stable and will not move.
4. Plug all open hydraulic ports.

**Note: While in storage, grease the turntable bearing every 6 months. See "Shear Lubrication" on page 23.**

# OPERATION

## BEFORE YOU START

### Know Your Safety Program

- Read and understand this manual and the base machine manual.
- Know the employer's safety rules. Consult your foreman for instructions and safety equipment.
- Learn the traffic rules at the work site. Know the hand signals used on the job and who is responsible for signaling. Take signals from only **ONE** person.
- Wear personal protection equipment (PPE) at all times. This includes eye protection, hard hat, steel toe shoes, leather gloves and hearing protection that conforms to standards ANSI Z87.1 (Eye and Face Protection), ANSI Z89.1 (Head Protection), ANSI Z41.1 (Foot Protection) and ANSI S12.6 (S3.19) (Hearing Protection).



Wear Eye Protection



Wear Ear Protection



Wear a Mask

### Know Your Equipment

- Learn and test the function of all controls. If malfunctions are found, shut the machine down and report the malfunction for repair.
- Be familiar with safety devices, indicators, warning devices and caution instructions. They will alert you to conditions that are hazardous.
- Know the clearances in the work area.

### Daily Safety Checks

- Ensure all decals are installed and legible. Contact LaBounty for replacements as required.
- Have a **DAILY** safety dialog with all workers. Inform them of any abnormal work that is planned. Remind them of the safe working distance.
- Clear the area. **ALWAYS** look out for others. In any work area, people constitute a serious safety hazard. Before operating, walk around the machine to ensure no workers are next to, under or on it. Warn nearby workers that you are starting up. **DO NOT** start up until they are out of danger. Review Job Safety Analysis (JSA) with all personnel in the immediate proximity to the work being done.
- Check the location of cables, gas lines and water mains before operation. Ensure work site footing has sufficient strength to support the machine. When working close to an excavation, position machine with the propel motors at the rear.
- Keep bystanders clear, especially before moving the boom, swinging the upper structure, or traveling.

**ALWAYS** be alert for bystanders in or near the operating area.

## SAFETY DEVICES

- Seat belts
- Safety decals
- Flags and flares
- Signs and other markings
- Falling Objects Protection Structures (FOPS) and Cab Guards
- Canopies
- Shields and guards
- Barricades
- Warning lights
- Visual or audible warning devices

### General Rules For Safe Operation

## DANGER

- Clear all persons and equipment from the area of operation and machine movement. **NEVER** move loads over people or equipment. When viewing the operation of the attachment, maintain a safe distance of at least 75 feet (23 meters).
- Maintain at least 15 feet (5 meters) between the attachment and any nearby power lines.

## WARNING

- **KNOW** the capacity of the excavator and it's attachments. **DO NOT** overload or serious injury could result. The attachment may have altered the machine's lift capabilities.
- **NEVER** leave the attachment suspended or pass it over people, occupied vehicles or buildings.
- **ALWAYS** lower the attachment to the ground and turn the base machine off when leaving the machine unattended.
- **DO NOT** close the jaws on a structure and reverse the excavator in an attempt to pull down material. This is dangerous and will damage the excavator and the attachment.

## CAUTION

- This attachment is for processing materials. **DO NOT** use for unapproved purposes.
- **DO NOT** continuously process oversized materials by forcing them into the jaw. This will shorten the life of the attachment.
- If attachment stalls, scale back the amount of material being processed at one time. Overloading can cause

- overheating or damage to the hydraulic system.
- Cycle the cylinder completely when processing. Fully cycling will allow hydraulic fluid to circulate and prevents overheating.
- When working in confined spaces, keep watch on exposed parts to avoid damage.
- Avoid collision of the boom or jaws, especially when working with limited visibility or inside buildings. Know the height and reach of the attachment during operation, transport and when swinging the excavator. Watch out for overhead obstacles.
- **DO NOT** alter factory preset hydraulics. This may void the warranty.
- **DO NOT** use attachment as a jack hammer or wrecking ball.
- **DO NOT** operate a poorly maintained or damaged attachment.
- The attachment is not a dozer. **DO NOT** position it on the ground and travel forward.
- Lifting lugs are to be used for shipping and installation. Do not use them in cable-hung applications.

## TECHNICAL SPECIFICATIONS

Model	Min. Excavator Weight 2nd Member	Min. Excavator Weight 3rd Member	Attachment Weight	Jaw Opening	Jaw Depth	Reach
MSD 2250	44,000 Lbs 20 mTons	88,000 Lbs 40 mTons	10,600 Lbs 4,800 Kg	30 In 760 mm	30 In 760 mm	8.6 Ft 2.6 M
MSD2250R	53,000 Lbs 24 mTons	99,000 Lbs 45 mTons	12,700 Lbs 5,750 Kg	30 In 760 mm	30 In 760 mm	11.7 Ft 3.6 M
MSD 2500	51,000 Lbs 23 mTons	88,000 Lbs 40 mTons	11,900 Lbs 5,400 Kg	31 In 790 mm	33 In 840 mm	8.7 Ft 2.7 M
MSD 2500R	66,000 Lbs 30 mTons	110,000 Lbs 50 mTons	14,800 Lbs 6,700 Kg	31 In 790 mm	33 In 840 mm	12.7 Ft 3.9 M
MSD 3000	66,000 Lbs 30 mTons	143,000 Lbs 65 mTons	14,200 Lbs 6,400 Kg	34 In 860 mm	37 In 940 mm	10 Ft 3 M
MSD 3000R	88,000 Lbs 40 mTons	154,000 Lbs 70 mTons	17,100 Lbs 7,700 Kg	34 In 860 mm	37 In 940 mm	13.1 Ft 4 M
MSD 4000	77,000 Lbs 35 mTons	143,000 Lbs 65 mTons	17,100 Lbs 7,800 Kg	38 In 970 mm	43 In 1,090 mm	11.5 Ft 3.5 M
MSD 4000R	99,000 Lbs 45 mTons	165,000 Lbs 75 mTons	19,800 Lbs 9,000 Kg	38 In 970 mm	43 In 1,090 mm	14.8 Ft 4.5 M

## CONTROLS



Learn the control for each movement of the attachment before attempting to operate.

### Second Member Control

**Note:** Rotation is controlled with an auxiliary control. Consult your distributor for excavator specific information.



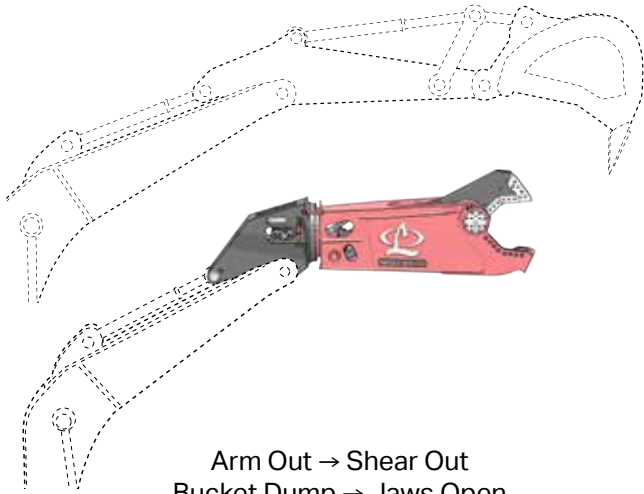

Arm Out → Shear Out  
 Bucket Dump → Jaws Open  
**FIGURE 13**

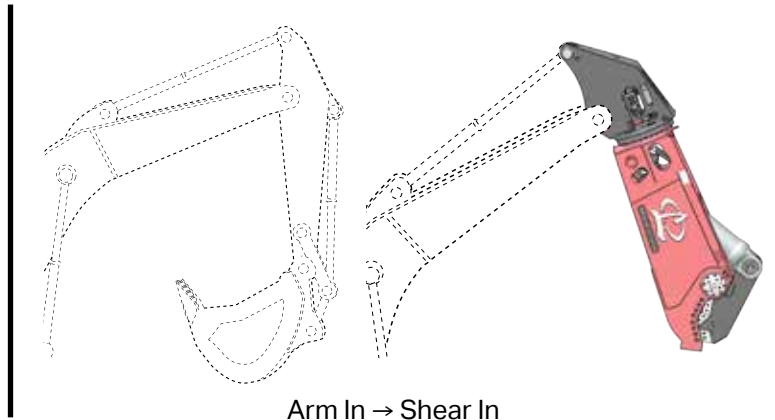

Arm In → Shear In  
 Bucket Curl → Jaws Closed  
**FIGURE 14**

### Third Member Control

**Note:** When installed as a third member, use the excavator auxiliary control to open and close the jaws.

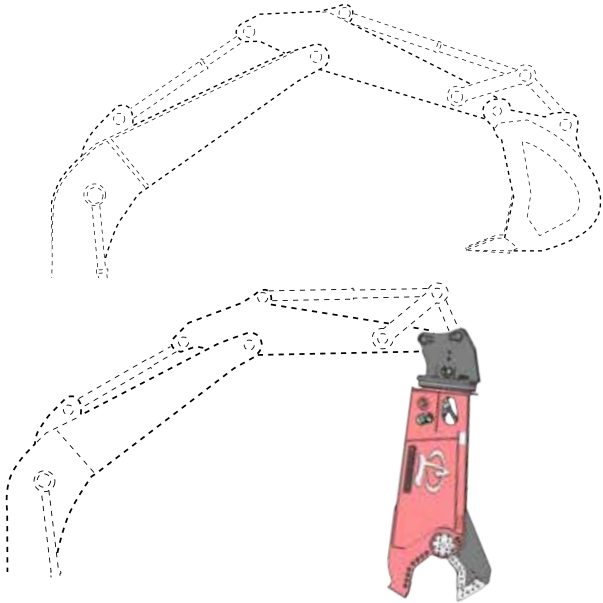

Bucket Curl → Shear In  
**FIGURE 15**

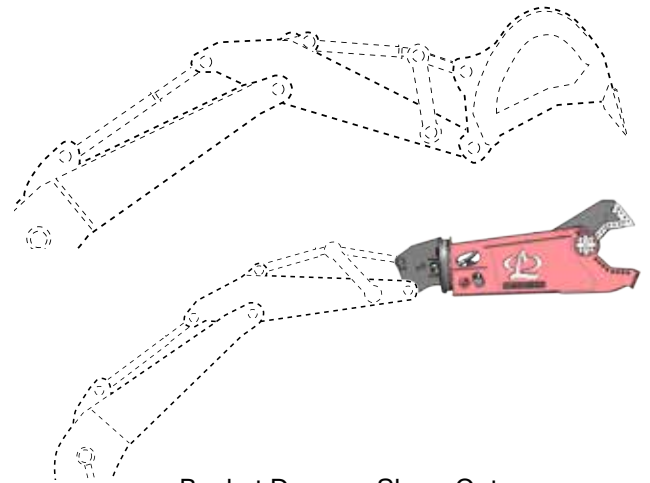

Bucket Dump → Shear Out  
**FIGURE 16**

## OPERATING TIPS

- The control levers should be moved in a gradual, deliberate way rather than with jerky, abrupt movements. Jerky movements will provide a rough ride in the cab and could give the appearance of instability.
- Avoid handling long, heavy materials off center. Excessive weight held out to one side can force the attachment to rotate or "Back-drive". Back-driving puts increased strain on the rotation system and, if done continually, can lead to rotation component problems. The rotator is for positioning only.
- Do not apply excavator force or weight at either end of the upper shear in an attempt to un-jam the shear or to cut materials that are too large.
- Avoid handling long, heavy materials off center.

- When processing oversized material, make partial bites to start the breakage and then back off before making the next partial bite. This will allow the broken material to fall away between bites.
- When processing any rigid member, use the rotator to square the jaws to the cut. If the jaws are not square, the rotator will back-drive to adjust to the cut.
- When shearing large steel members, such as I-beams or tubing, try doing it in two cuts rather than one. Pierce the material about halfway through with the first cut, and then finish it off with the second cut.
- The shear jaws are best capable of processing light, thinner gauge materials immediately after performing blade maintenance. When processing larger materials, the condition of the blades are not as critical. See "Blade Maintenance" on page 26.
- Sort your scrap to get the highest capacity from the attachment.
- Start processing smaller materials and work up to larger materials. This will help you learn the limitations of the machine and will allow the machine to warm up properly.
- Understand that the attachment does have limits. Sometimes it may be necessary to downsize very large material by another method before the attachment can process it effectively.
- Cut material deliberately. Do not plunge the jaws into a pile of material and cut indiscriminately.
- Keep the attachment properly maintained. Jaws with excessive blade gaps or dull teeth are much less effective. Lack of maintenance can lead to greater problems and potential downtime.
- Only use the force of the cylinder to cut material. Do not attempt to apply other forces on the shear to aid in material processing.
- The rotation function is for positioning only. Do not use it for bending, breaking or prying.

## **BLEED THE SHEAR HYDRAULIC CIRCUIT**

Air must be bled out of the hydraulic circuit prior to operation. Air in the system leads to cavitation, oxidation of the oil and excessive heat. These conditions promote hydraulic oil break-down, contamination, noise, sluggish operation, reduced component life and potential cylinder damage.

1. Start with the shear in the vertical position.
2. Set the excavator at idle speed.
3. Slowly open the jaws until a noticeable change in tone of the excavator is heard, indicating a full cylinder. Release the controls and do not continue to apply full operating pressure to the cylinder.
4. Slowly close the jaws until the cylinder rod is extended approximately 1/4 stroke.
5. Open the jaws to retract the cylinder all the way.
6. Repeat steps 3 and 4. Extend the cylinder a quarter stroke more each time, until you reach full stroke.
7. Slowly cycle back and forth, at least five times, to full stroke. Be careful not to apply full operating pressure to the cylinder at this time.
8. Check the base machine hydraulic fluid level and fill if necessary.
9. Slowly extend and retract the excavator cylinder to it's limits. Check for interference between the attachment and the excavator boom or stick. Check the hydraulic lines that connect to the attachment. Ensure they are not rubbing or becoming damaged in any way. Contact your dealer immediately if interference occurs.

## BLEED INSITE

1. Remove the cover from the InSite box.
2. Connect a bleed hose (part number 227831) to the CW and CCW bleed couplers on the InSite control box. Be aware that the shear may move slightly when connected.

Note: If you have a non-rotating shear, you will not have CW and CCW bleed couplers.

### ⚠ CAUTION

Do not connect the CW or CCW connections to the ROD or BORE connections. Seal damage and unexpected movement may result.

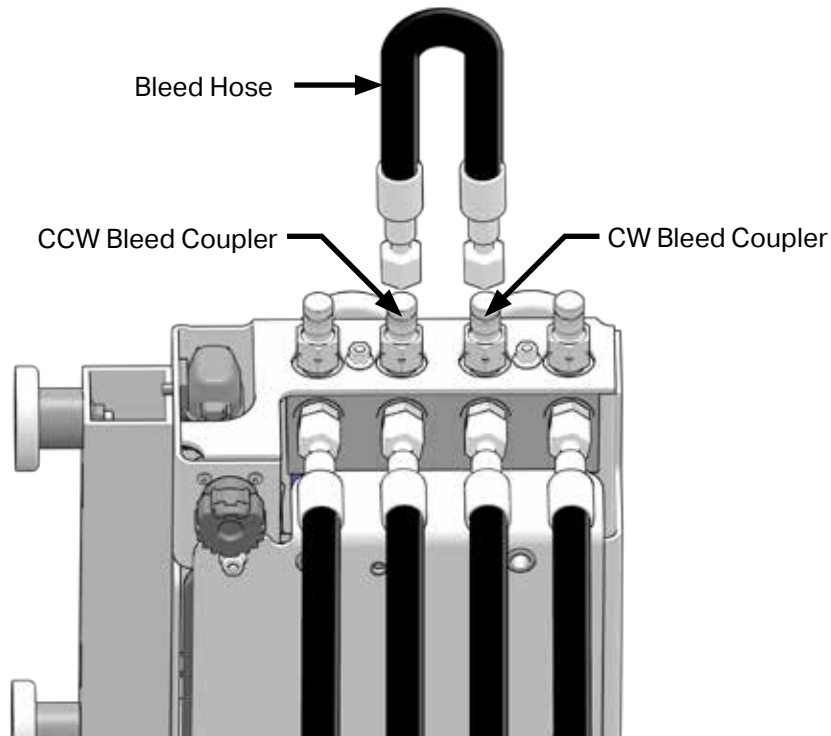

### ⚠ WARNING

Clear all persons and equipment from the area of operation and machine movement. NEVER move loads over people or equipment. When viewing the operation of the attachment, maintain a safe distance of at least 75 feet (23 meters).

3. Power up the excavator and make one full rotation in both the clockwise and counter clockwise directions.
4. Power down the excavator and relieve hydraulic pressure.
5. Disconnect the bleed hose from the CW and CCW bleed couplers.

### ⚠ CAUTION

Do not connect the CW or CCW connections to the ROD or BORE connections. Seal damage and unexpected movement may result.

6. Connect a bleed hose (part number 227831) to the ROD and BORE bleed couplers on the InSite control box.

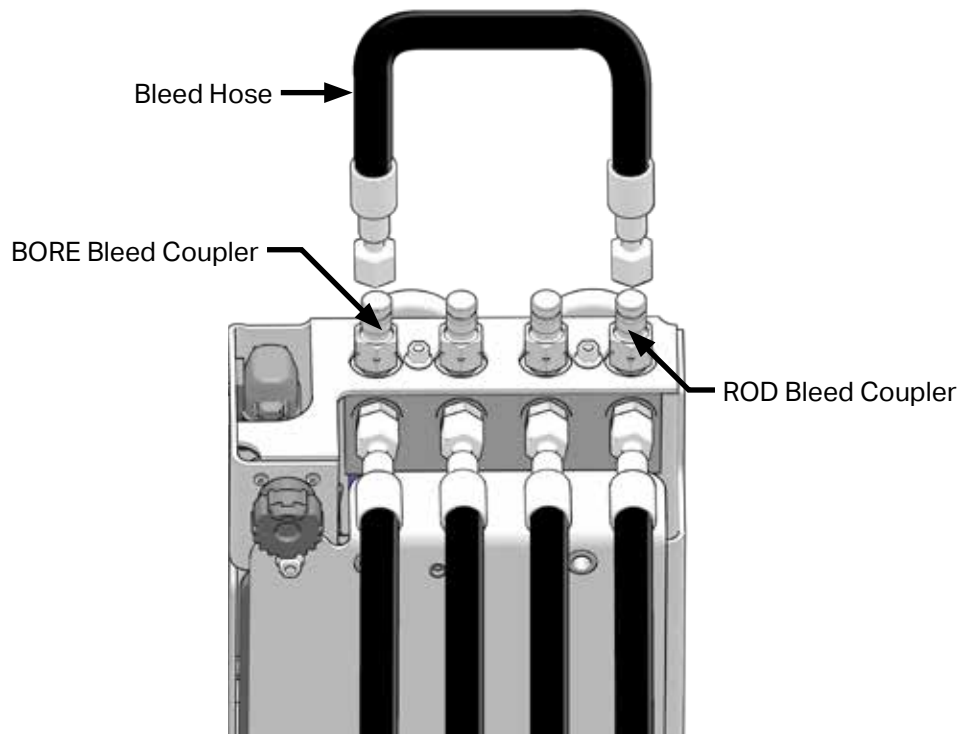

## **! WARNING**

**Clear all persons and equipment from the area of operation and machine movement. NEVER move loads over people or equipment. When viewing the operation of the attachment, maintain a safe distance of at least 75 feet (23 meters).**

7. Power up the excavator and fully open and close the shear jaws.
8. Power down the excavator, relieve hydraulic pressure and remove the bleed hose from the bleed couplers.

## **CHECK FOR LEAKS**

## **! WARNING**

**Keep hands and body away from pinholes and nozzles which eject fluids under pressure. Escaping fluid under pressure can penetrate the skin, causing serious injury. Use a piece of cardboard to search for leaks.**

1. Starting at idle, or low hydraulic flow, operate the shear.
2. Visually inspect the attachment for leaks.
3. Set the hydraulic power supply to full operation flow and pressure.
4. Visually inspect the attachment for leaks.
5. Check the hydraulic oil reservoir and fill as stated in the excavator manual.

# MAINTENANCE

## 8-HOUR INSPECTION CHECKLIST

### Inspect all safety devices

- \_\_\_\_\_ Safety decals are in place and legible (see "Decals" on page 6)
- \_\_\_\_\_ Cab protection and guarding is installed and in good condition.
- \_\_\_\_\_ Excavator warning systems are working.

### Visually inspect for damage

- \_\_\_\_\_ Check for physical damage to the attachment, jaws, hoses , lines and fittings.
- \_\_\_\_\_ Check rotation connections for wear, leaks or failure (see "Hydraulic Inspection" on page 23).

### Lubricate all points

- \_\_\_\_\_ Lubricate shear & turntable bearing, if equipped (see "Shear Lubrication" on page 23).
- \_\_\_\_\_ Lubricate the planetary gearbox, if equipped (see "Planetary Gearbox Lubrication" on page 24).

### Inspect bolts and hydraulic fittings

- \_\_\_\_\_ Inspect and tighten all bolts and fittings (see "Inspect / Torque Bolts" on page 25).

### Inspect connecting pins and retaining hardware for damage or wear. Replace if necessary.

- \_\_\_\_\_ Arm / Boom Connection.
- \_\_\_\_\_ Link / Arm connection.
- \_\_\_\_\_ Front and rear cylinder pins.
- \_\_\_\_\_ Main pivot group pin.

### Inspect blades

- \_\_\_\_\_ Inspect blade gaps and shim if necessary (see "Measuring & Shimming Blade Gaps" on page 28).
- \_\_\_\_\_ Torque all blade bolts (see "Inspect / Torque Bolts" on page 25)

Inspected By: \_\_\_\_\_ Date: \_\_\_\_\_

## 80-HOUR INSPECTION CHECKLIST

### Build-up, hard-surfacing & Blade Rotation

\_\_\_\_\_ Build-up jaws and hard surface, if necessary (See "Jaw Build Up & Hardsurfacing" on page 38).

\_\_\_\_\_ Check wear plates and bars. Replace if necessary (see "Replace Wear Plates & Bars" on page 41).

\_\_\_\_\_ Inspect slide screw (see "Slide Screw Adjustment" on page 41).

\_\_\_\_\_ Rotate blades (see "Blade Rotation" on page 31). Record which rotation you performed.

\_\_\_\_\_ First Rotation \_\_\_\_\_ Second Rotation \_\_\_\_\_ Third Rotation \_\_\_\_\_ Fourth Rotation

\_\_\_\_\_ Inspect the cylinder gap (see "Check the Cylinder Gap" on page 42).

Inspected By: \_\_\_\_\_ Date: \_\_\_\_\_

## 1500-HOUR INSPECTION CHECKLIST

\_\_\_\_\_ Replace rotation bolts (see "Inspect / Torque Bolts" on page 25 for proper bolt size and class).

Inspected By: \_\_\_\_\_ Date: \_\_\_\_\_

## 2,000- HOUR INSPECTION CHECKLIST

### Replace Select Seals

\_\_\_\_\_ Replace cylinder seals.

\_\_\_\_\_ Replace swivel manifold seals, if equipped.

Inspected By: \_\_\_\_\_ Date: \_\_\_\_\_

## HYDRAULIC INSPECTION

### ⚠ CAUTION

Wear personal protection equipment at all times. This includes eye protection, hard hat, steel toe shoes, leather gloves and hearing protection.

1. Locate flat, hard ground and place the attachment on the ground.
2. Check the hydraulic oil reservoir and ensure it is filled.
3. Visually inspect all hydraulic hoses and lines for leaks or damage.

### ⚠ WARNING

Trapped hydraulic pressure may be present after the base machine is shut off. Extreme caution must be taken when removing hydraulic hoses or lines. Injury or death could result.

## SHEAR LUBRICATION

Use premium grease, No. 2EP. Grease fittings are shown with yellow "GREASE" decals. Each grease fitting requires .3 oz (8 g) of grease every 8 hours. This is about 6 shots of grease from an average grease gun.

**Note:** Follow all OEM lubrication instructions as it pertains to the cylinder and stick / boom connections.

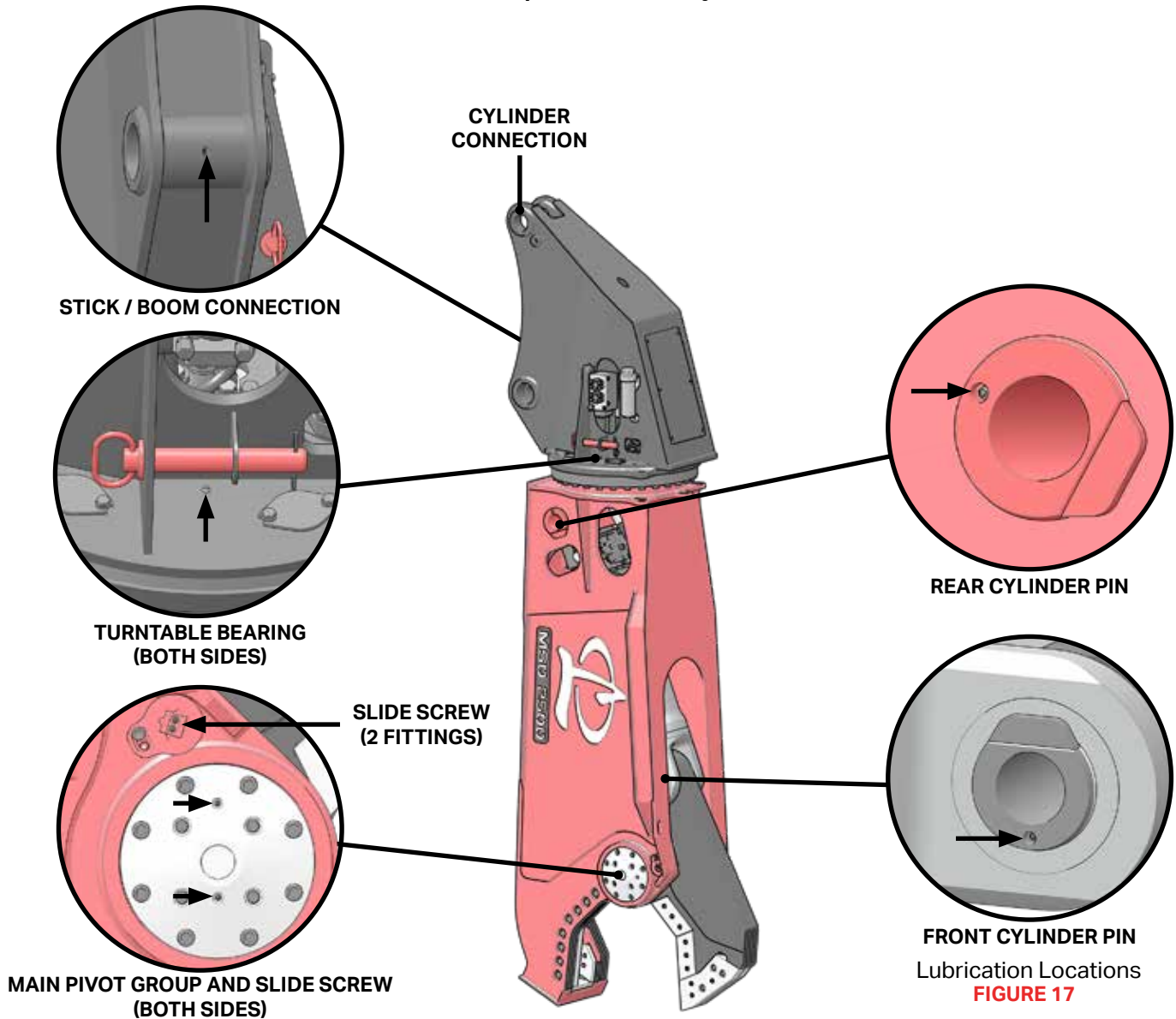

# PLANETARY GEARBOX LUBRICATION

Some models use a planetary gearbox to rotate the attachment. The gearbox oil must be changed regularly, based on the schedule below.

Planetary Gearbox Oil Change Schedule			
FIRST 50 hours	250 hours / 6 months	500 hours / 1 year	1000 hours / 2 years
SAE 80W - 90	Inspect oil and fill if needed	Synthetic ISO 150 @ 104°F	Synthetic ISO 460 @ 104°F

1. Ensure the shear is on hard, flat ground and has been secured for maintenance.
  2. Remove the cover plate from the rotating head.
  3. Remove the oil fill plug.
  4. Remove the oil drain plug. Drain the oil into a container larger than 3 quarts.
- Note: The plugs are magnetic and will collect metal debris. Discard any found debris.**
5. Install the oil drain plug.
  6. Fill the gearbox with oil, as specified in the LaBounty Parts Manual (shipped with the attachment).
  7. Install the oil fill plug.

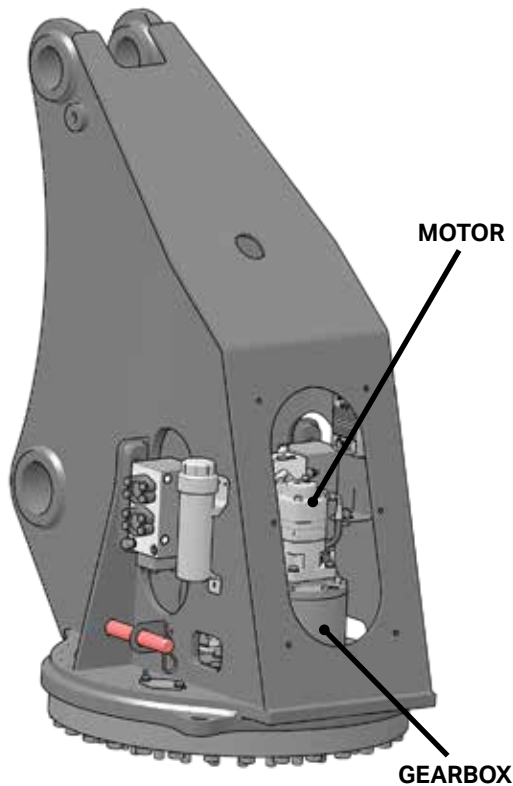

Planetary Gearbox Location  
**FIGURE 18**

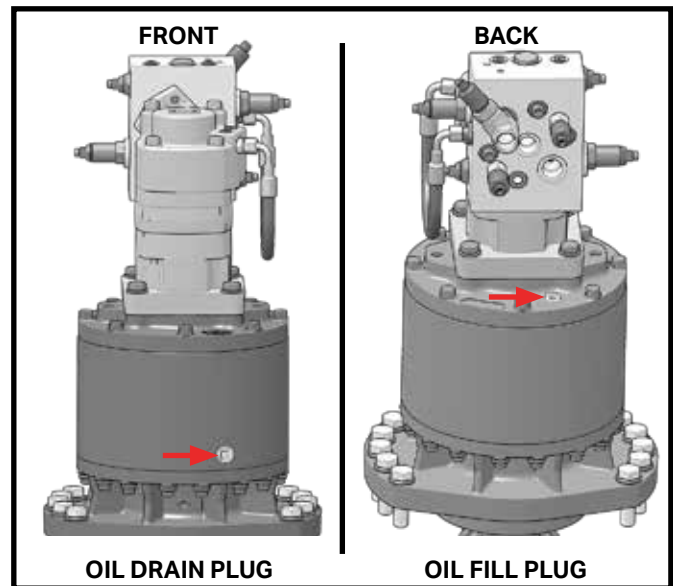

Gearbox Drain and Fill Plugs  
**FIGURE 19**



## INSPECT / TORQUE BOLTS

Inspect all bolts for damage. Check the torque of all bolts and replace any bolt that is damaged or has been re-torqued more than once. Replace rotation bolts after 1500 hours / 2 years. Always use replacement bolts of the same size and class as the one removed. Unless otherwise specified, use class 10.9 metric hex head cap screws, class 10.9 metric flat head cap screws and class 12.9 metric socket head cap screws. When installing new bolts, ensure that the bolt is clean and dry.

**Note: Some bolts have unique torque specifications. Refer to the LaBounty Parts Manual.**



**Never use an inferior class fastener. Fastener failure can cause damage, injury or death.**

General Fastener Torque Table		
Size	Class 10.9	Class 12.9
M10	45 Ft. Lbs. (65 Nm)	50 Ft. Lbs. (70 Nm)
M12	75 Ft. Lbs. (105 Nm)	85 Ft. Lbs. (115 Nm)
M16	175 Ft. Lbs. (240 Nm)	210 Ft. Lbs. (285 Nm)
M20	335 Ft. Lbs. (455 Nm)	405 Ft. Lbs. (550 Nm)
M24	580 Ft. Lbs. (790 Nm)	695 Ft. Lbs. (945 Nm)
M30	1165 Ft. Lbs. (1580 Nm)	1395 Ft. Lbs. (1895 Nm)

Blade Fastener Torque Table		
Size	Class	Torque
M20	10.9	500 Ft. Lbs. (680 Nm)
M24	10.9 / 12.9	900 Ft. Lbs. (1220 Nm)
M30	10.9	1200 Ft. Lbs. (1630 Nm)

Hydraulic Flange Fastener Torque Table			
Size	Class	Cap screw Size	Torque
0.75"	61	M10 x 1.50	45 Ft. Lbs. (65 Nm)
1.00"	61	M10 x 1.50	45 Ft. Lbs. (65 Nm)
1.25"	61	M12 x 1.75	70 Ft. Lbs. (95 Nm)
1.50"	61	M12 x 1.75	70 Ft. Lbs. (95 Nm)
2.00"	61	M12 x 1.75	70 Ft. Lbs. (95 Nm)
1.00"	62	M12 x 1.75	70 Ft. Lbs. (95 Nm)
1.25"	62	M12 x 1.75	70 Ft. Lbs. (95 Nm)
1.25"	62	M14 x 2.00	115 Ft. Lbs. (160 Nm)
1.50"	62	M16 x 2.00	225 Ft. Lbs. (305 Nm)
2.00"	62	M20 x 2.5	435 Ft. Lbs. (590 Nm)

Speed Valve Fastener Torque Table		
Size	Class	Torque
M18	12.9	350 Ft. Lbs. (475 Nm)
M20	12.9	370 Ft. Lbs. (505 Nm)

Turntable Fastener Torque Table		
Size	Class	Torque
M20	10.9	435 Ft. Lbs. (590 Nm)
M20	12.9	525 Ft. Lbs. (715 Nm)
M24	10.9	755 Ft. Lbs. (1025 Nm)
M24	12.9	900 Ft. Lbs. (1220 Nm)
M30	10.9	1515 Ft. Lbs. (2055 Nm)
M30	12.9	1800 Ft. Lbs. (2445 Nm)
1.00"	L-9	900 Ft. Lbs. (1220 Nm)
1.50"	ZN-L-9	2600 Ft. Lbs. (3525 Nm)

Rotation Assembly Fastener Torque Table		
Size	Class	Torque
M10	12.9	50 Ft. Lbs. (70 Nm)
M12	10.9	75 Ft. Lbs. (105 Nm)
M16	10.9	175 Ft. Lbs. (240 Nm)
M20	10.9	335 Ft. Lbs. (455 Nm)
0.38"	GR. 8	45 Ft. Lbs. (65 Nm)
0.50"	GR. 8	110 Ft. Lbs. (150 Nm)
0.75"	GR. 8	380 Ft. Lbs. (515 Nm)

Cylinder Assembly Fastener Torque Table		
Size	Class	Torque
M24	10.9	750 Ft. Lbs. (1020 Nm)

Speed Valve Fastener Torque Table			
Valve	Size	Class	Torque
513029	M20	12.9	370 Ft. Lbs. (505 Nm)
514444	M18	12.9	370 Ft. Lbs. (505 Nm)

# BLADE MAINTENANCE

## Overview

The MSD Legend shear has eight blades that must be maintained regularly to ensure the attachment has a long and dependable service life. Blade maintenance requires that all blade gaps and hardware torques are checked and adjusted if necessary every 8 hours. Every 80 hours, the slide screw must be adjusted and blade positions must be rotated. This will ensure uniform wearing of the blades and will prevent material jams.

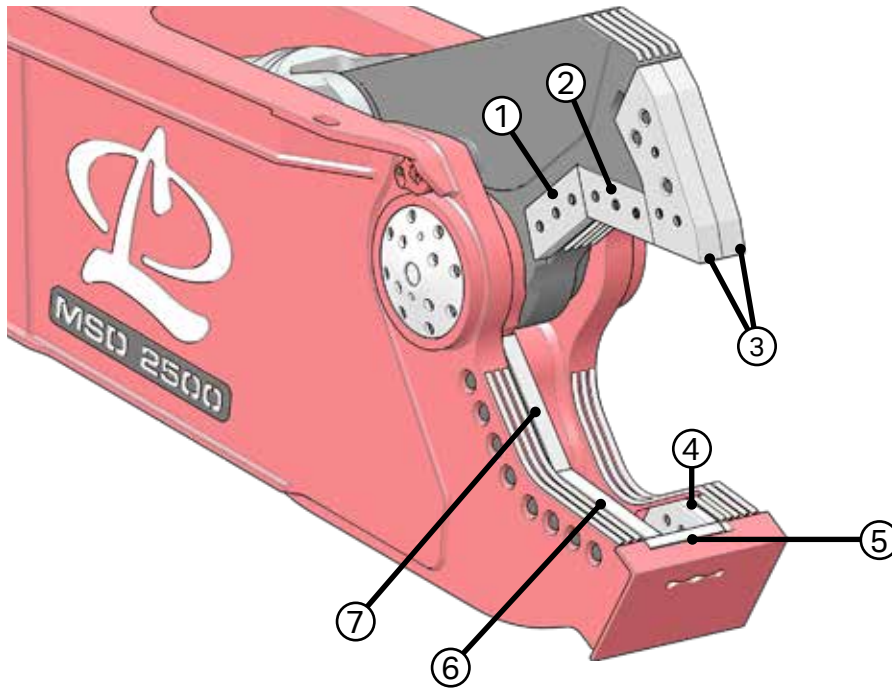

Blade	
1	Upper Primary
2	Upper Secondary
3	Piercing Tips
4	Guide Blade
5	Cross Blade
6	Lower Secondary
7	Lower Primary

## ⚠ CAUTION

Wear gloves at all times during blade maintenance. Hands may be exposed to hazards, cuts, abrasions and heat.

## BLADE REMOVAL

## ⚠ CAUTION

Wear personal protection equipment at all times. This includes eye protection, hard hat, steel toe shoes, leather gloves and hearing protection.

## ⚠ WARNING

Shear blades are very heavy. Do not remove a blade if its not supported. The blade may fall and cause injury.

**Note:** Removing and handling blades can be hazardous if done incorrectly.

1. Before removing blades, position the shear on the ground, so that the blades being removed are close to the ground. When removing upper blades or piercing tip, curl the shear, as shown in Figure 20.

**Note:** For non-rotating shears, knuckle the shear under the boom, as shown in Figure 20, to replace the upper jaw blades and piecing tip. Extend the shear completely out and set it on the ground to service the lower blades.

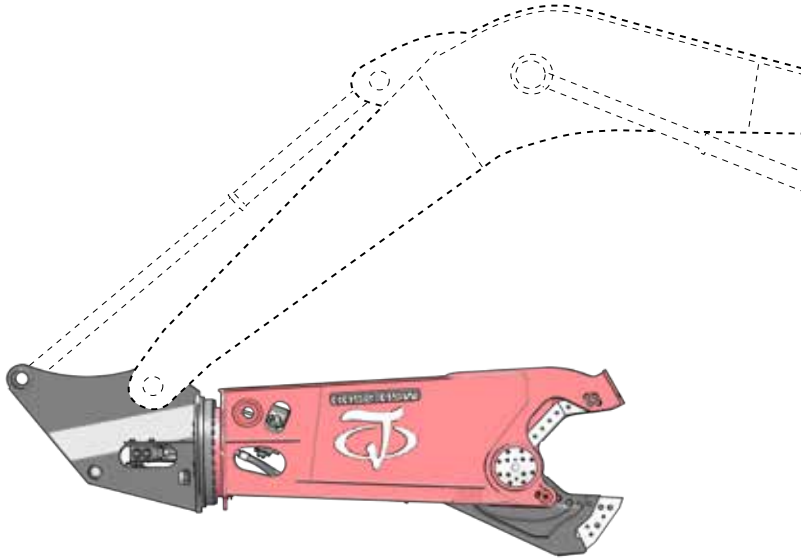

Curl the Shear Under  
**FIGURE 20**

**Loosening Blades**

1. Back out the bolts holding the blade in place. Ensure the bolts are still threaded into the blade.



**Never strike the blade with a hardened steel tool. The blade may chip and cause severe injury.**

2. If the blades are not loose, tap on the blade face with a soft-faced mallet.
3. Use a pry bar between the blade and blade seat to loosen the blade.



**Do not strike the blade bolts directly with a hammer or other hard object. This may cause damage to the blade.**

4. If the blade is still not loose, place a wood block against the head of one of the blade bolts. Strike it with a mallet.

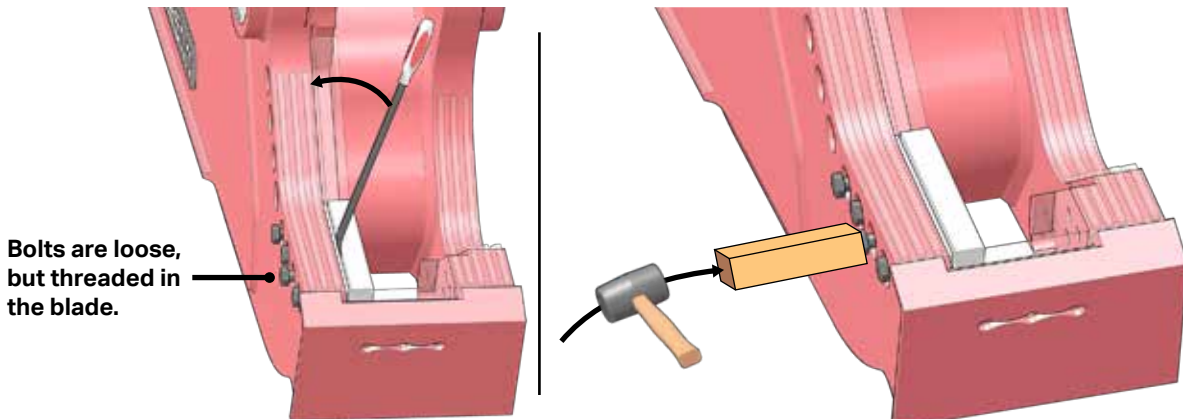

Loosen the Blades  
**FIGURE 21**

5. If the blade is still jammed, contact your LaBounty dealer for further assistance.

### Removing Blades

LaBounty shear blades are designed so that you may use the blade mounting bolts as handles to aid in removing blades.

1. Remove one bolt from each end of the blade being removed.
2. Thread the bolts back into their original holes, from the opposite side of the blade, as shown in Figure 22.

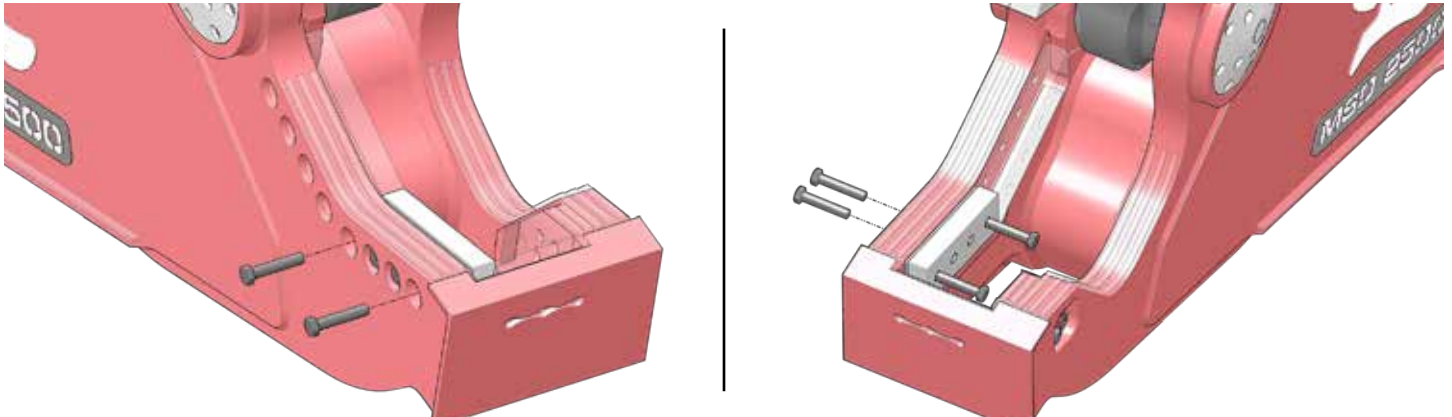

Blade Handles  
**FIGURE 22**

3. Using the two backwards bolts as handles, hold the blade in place while a helper removes the final blade bolts.
4. Carefully remove the blade.

### Prior to Installation of blades

Before installing shear blades...

1. Inspect all mating surfaces on the blades and on the blade seat. Ensure there is no dirt or debris that would prevent a tight fit.
2. Clean all surfaces with a wire brush or a needle scaler, if necessary.
3. Use a grinder to clean up blade edges. Remove sharp burrs and smooth out deformations.

**Note: Use caution when cleaning the blade seat. Excessive grinding will damage the machined blade seat.**

## MEASURING & SHIMMING BLADE GAPS

**! WARNING**

**Do not check blade gaps while the shear is in motion. Stay clear when moving the jaws or injury could result.**

**! WARNING**

**Stay at least 75 feet (23 m) away from the shear when its moving. Severe injury could result.**

### Guide Blade

The guide blade supports the upper jaw. The gap must be checked every 8 hours of operation and each day, before using the attachment.

1. Cycle the shear jaw until the side of the piercing tip begins to overlap the guide blade.
2. Measure the gap in multiple places using a feeler gauge. The gap should be less than .030 inches (.762 mm).
3. If the gap is larger than specified, remove the guide blade and add shims until the gap is as specified in the blade gap table (Page 30).

**Note: When reinstalling the guide blade, torque bolts to values shown in "Inspect / Torque Bolts" on page 25.**

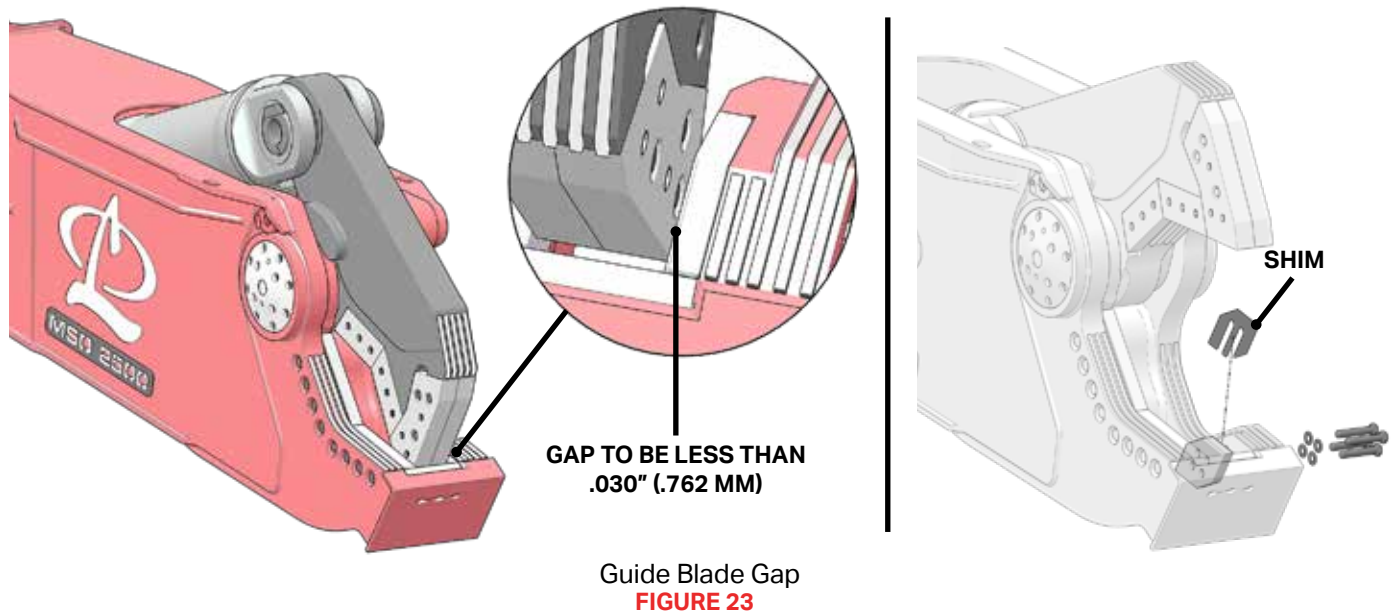

Guide Blade Gap  
**FIGURE 23**

### Secondary Blades

The upper and lower jaw secondary blades must be parallel with each other and have less than .030 inch (.762 mm) gap. Check the secondary blades gap every 8 hours of operation and each day, before using the attachment.

**Note: For most applications a gap of .010 - .020 inches (.254 - .508 mm) will yield the best results. If jamming is a problem with your specific material, the gap may be shimmed to .005 (.127 mm) inches.**



**Shear blades are very heavy. Do not remove a blade if its not supported. The blade may fall and cause injury.**

1. Cycle the shear jaw until the upper and lower secondary blades overlap.
  2. Measure the gap in multiple places using a feeler gauge. The gap should be less than .030 (.762) inches.
- Note: For most applications a gap of .010 - .020 inches (.254 - .508 mm) will yield the best results. If jamming is a problem with your specific material, the gap may be shimmed to .005 (.127 mm) inches.**

3. If the gap is larger than specified, you will need to shim the lower secondary blade.
4. Loosen the three bolts that hold the lower secondary blade in the blade seat.
5. Slide the blade so you can access the adjustment plate.
6. Add shims between the blade and adjustment plate until the gap is as specified in the blade gap table (Page 30).

**Note: When reinstalling the adjustment plates, ensure the notch is towards the shear.**

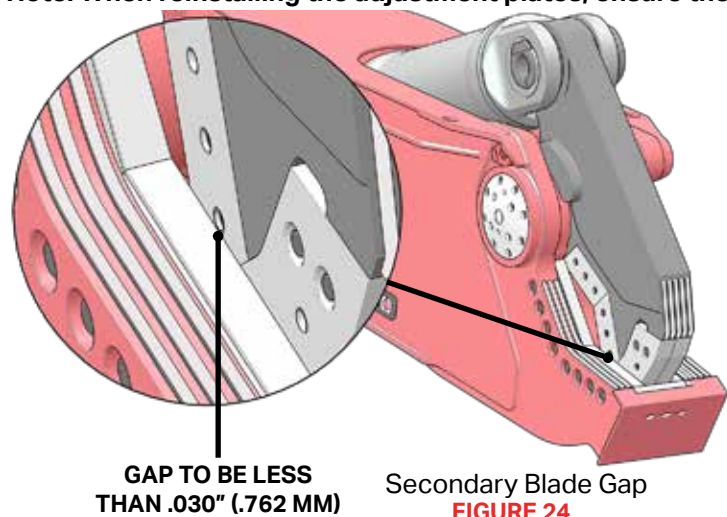

Secondary Blade Gap  
**FIGURE 24**

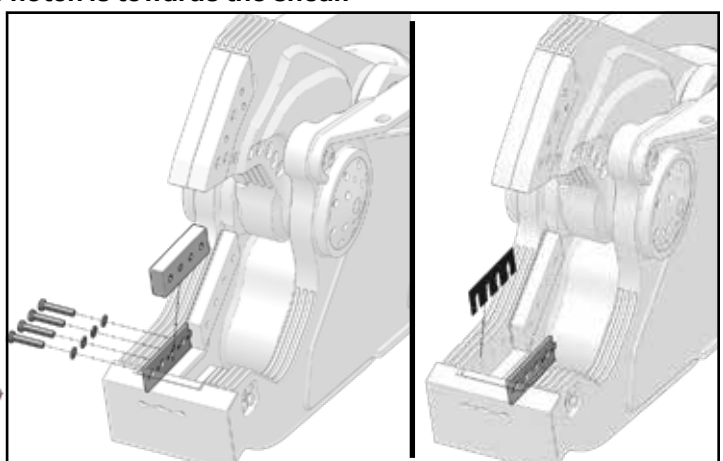

Shimming the Lower Secondary Blade  
**FIGURE 25**

The upper and lower primary blades must be parallel with each other and have less than .030 inch (.762 mm) gap. Check the primary blades gap every 8 hours of operation and each day, before using the attachment.

1. Cycle the shear jaw until the upper and lower primary blades overlap.
  2. Measure the gap in multiple places using a feeler gauge. The gap should be less than .030 inches (.762 mm).
- Note: For most applications a gap of .010 - .020 inches (.254 - .508 mm) will yield the best results. If jamming is a problem with your specific material, the gap may be shimmed to .005 inches (.127 mm).**
3. If the gap is larger than specified, you will need to shim the lower primary blade.
  4. Loosen the bolts that hold the lower primary blade in the blade seat.
  5. Slide the blade so you can access the adjustment plate.
  6. Add shims between the blade and adjustment plate until the gap is specified in the blade gap table (Page 30).
  7. Torque both the primary and secondary blade bolts to values shown in "Inspect / Torque Bolts" on page 25.

**Note: When reinstalling the adjustment plates, ensure the notch is towards the shear.**

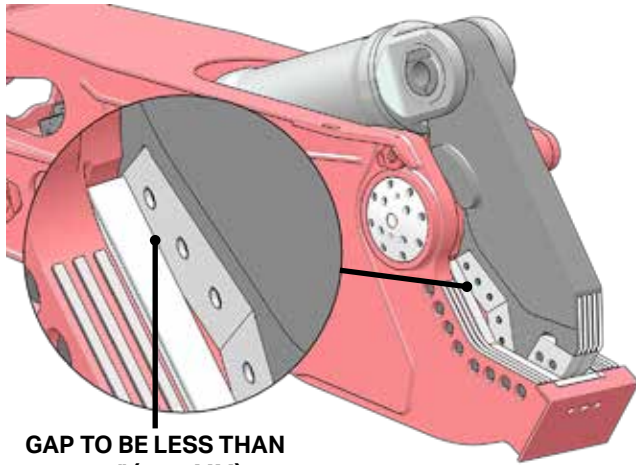

Primary Blade Gap  
**FIGURE 26**

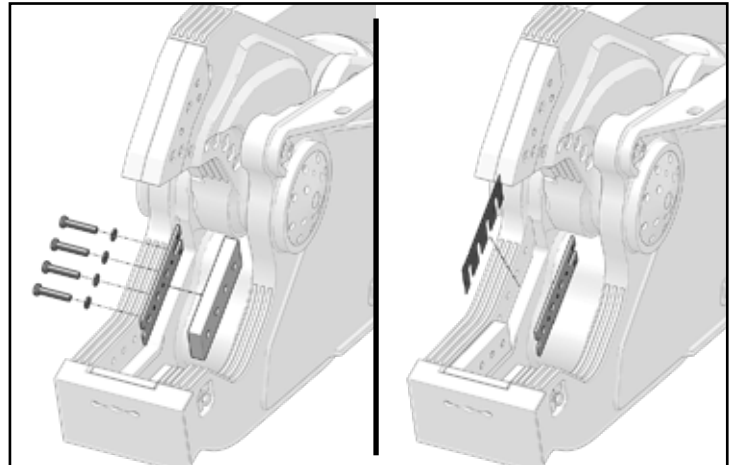

Shimming the Lower Primary Blade  
**FIGURE 27**

Cutting Blade Gap Table	
Model	Gap Specification
MSD1000	0.010" (.254 mm)
MSD1500	
MSD 2000	
MSD 2250	
MSD 2500	
MSD 3000	

### Special Applications

Some applications, such as cutting stainless steel, aluminum or thin material, may require the blade gaps to be shimmed smaller or larger. When using the shear in these special applications, contact LaBounty Customer Service for proper blade gap measurements.

## BLADE ROTATION

Each LaBounty cutting blade has four usable edges. Each blade can be flipped and rotated to use all four edges (see Figure 28 & Figure 29). The blades must be rotated every 80 hours, when the blade edge is rounded to .25" radius or if the blade is damaged. Some special applications will require a more frequent blade change schedule. The blade rotation procedure will help you get the maximum life from your LaBounty blades. Blade rotation is a four step process, which is repeated for the life of the shear. Every 80 hours, you will perform one step in the process.

**Note: Mark which blade flip you have performed on the "80-Hour Inspection Checklist" on page 22.**

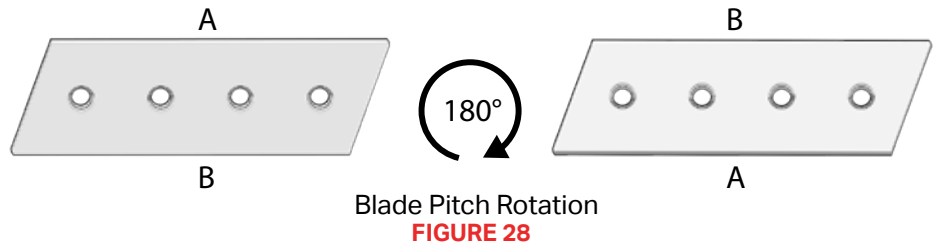

Blade Pitch Rotation  
**FIGURE 28**

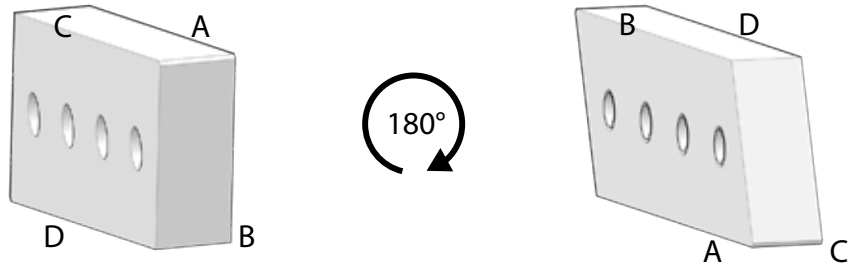

Blade Roll Rotation  
**FIGURE 29**

### ⚠ CAUTION

Wear personal protection equipment at all times. This includes eye protection, hard hat, steel toe shoes, leather gloves and hearing protection.

### ⚠ WARNING

Shear blades are very heavy. Do not remove a blade if its not supported. The blade may fall and cause injury.

### 1<sup>ST</sup> ROTATION

In the first blade rotation, flip the lower and upper blades 180°, end over end (Pitch Rotation). Then, return them to their original blade seats.

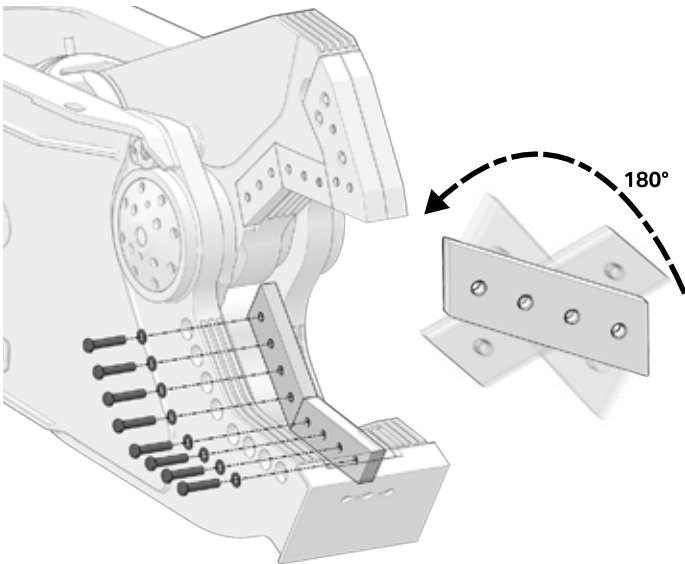

1. Set the shear on the ground. Remove the lower blades. Rotate each lower blade, end over end, 180° (Pitch Rotation). Return them to their original blade seats.

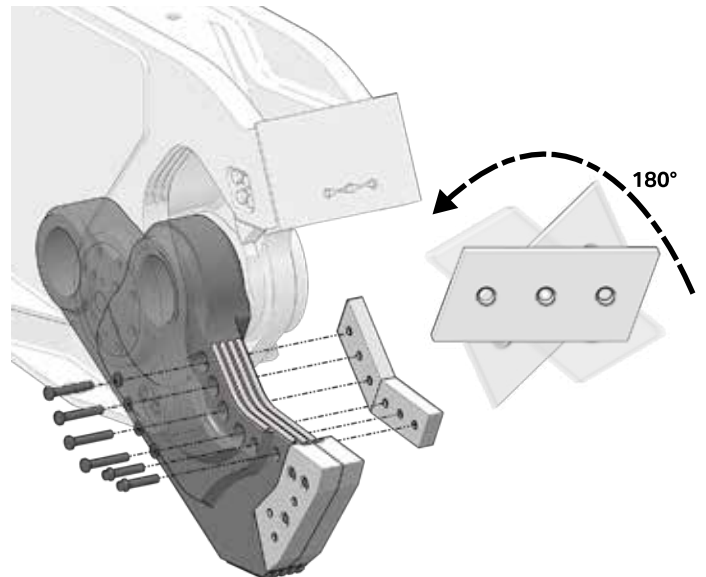

2. Place the shear upside down so the upper is close to the ground. Rotate each upper blade, end over end, 180° (Pitch Rotation). Return them to their original blade seats. Shim as shown in "Measuring & Shimming Blade Gaps" on page 28

## 2<sup>ND</sup> ROTATION

In the second rotation, remove each blade, perform a 180° roll rotation, then move it to a different blade seat. The piercing tip blades will also be rotated. If you are using the shear in a heavy piercing application, rotate or replace the piercing tip blades more frequently.

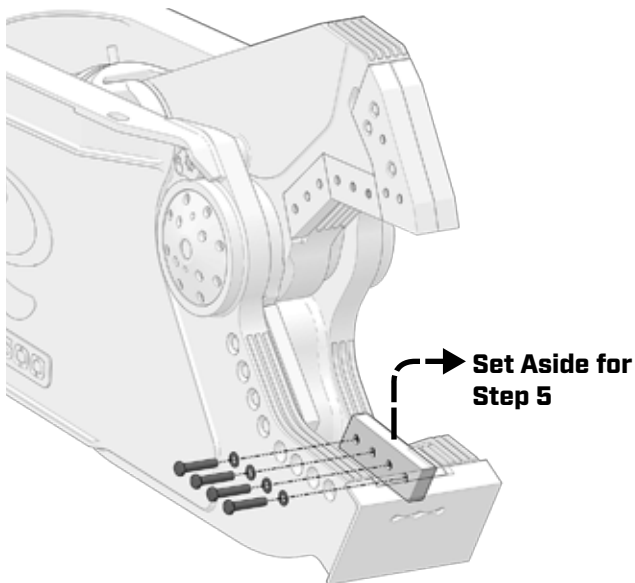

1. Remove the lower secondary blade. Set aside

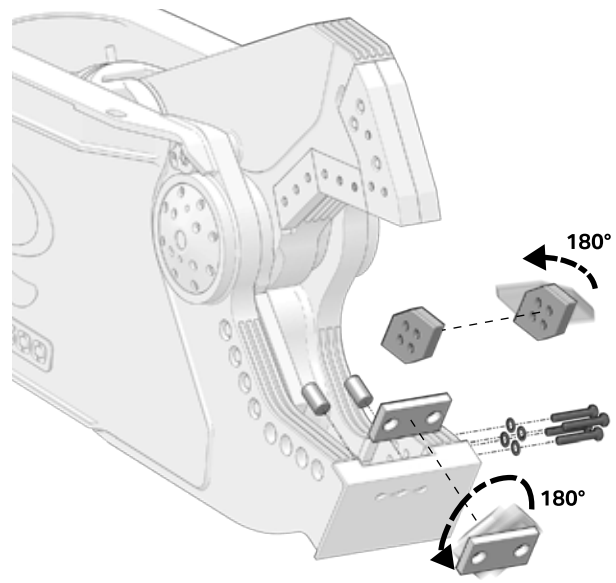

2. Remove the cross blade and the guide blade. Flip each of them, end over end, 180° (Pitch Rotation). Return the blades to their seats and lightly tighten the bolts.

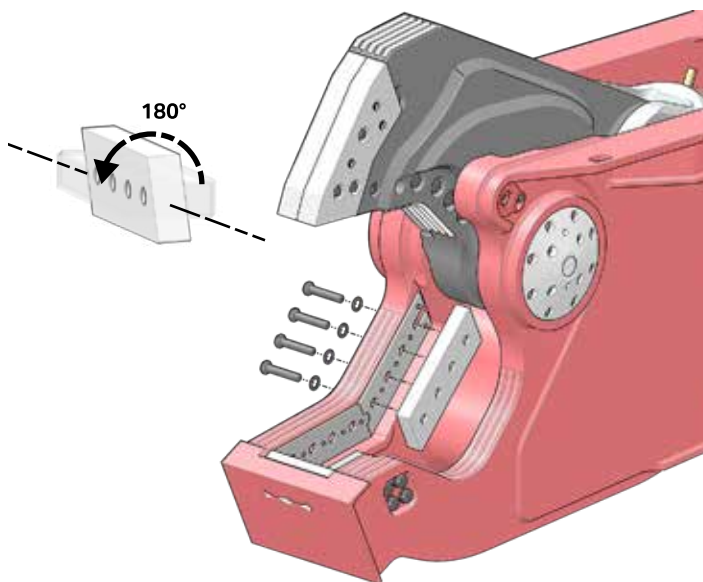

3. Remove the lower primary blade. Rotate the blade, along the long edge, 180° (Roll Rotation).

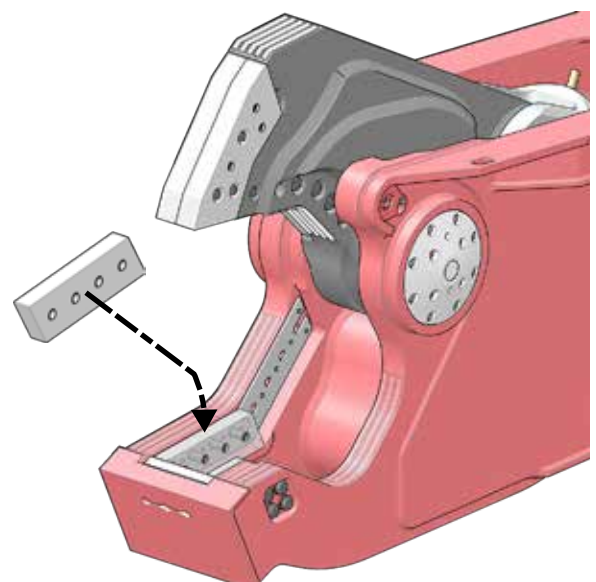

4. Install the lower primary blade into the lower secondary blade seat.



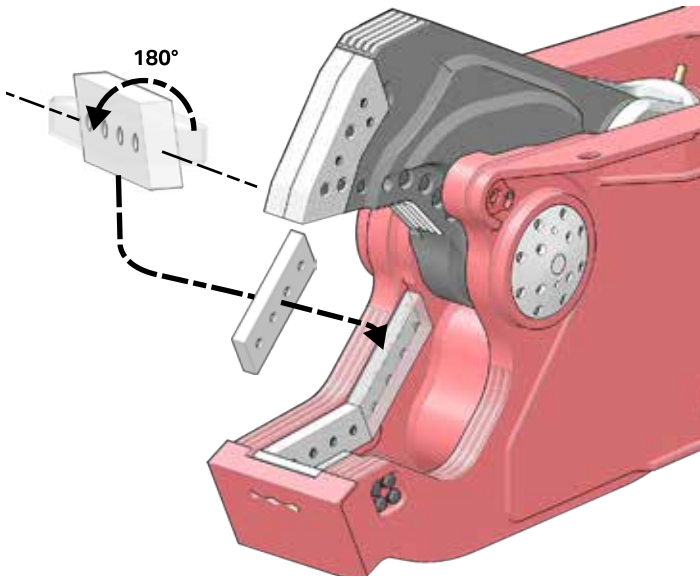

5. Rotate the previously set aside lower secondary blade (step 1), along the long edge, 180° (Roll Rotation). Install the blade into the lower primary blade seat.

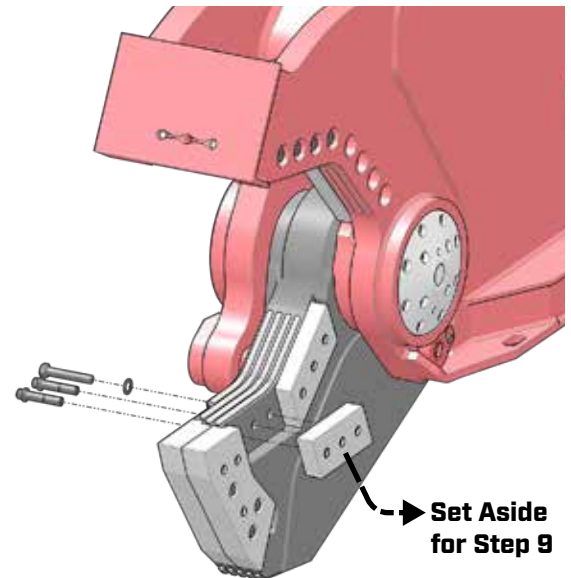

6. Place the shear upside down so that the upper blades are as close to the ground as possible. Remove the upper secondary blade and set aside.

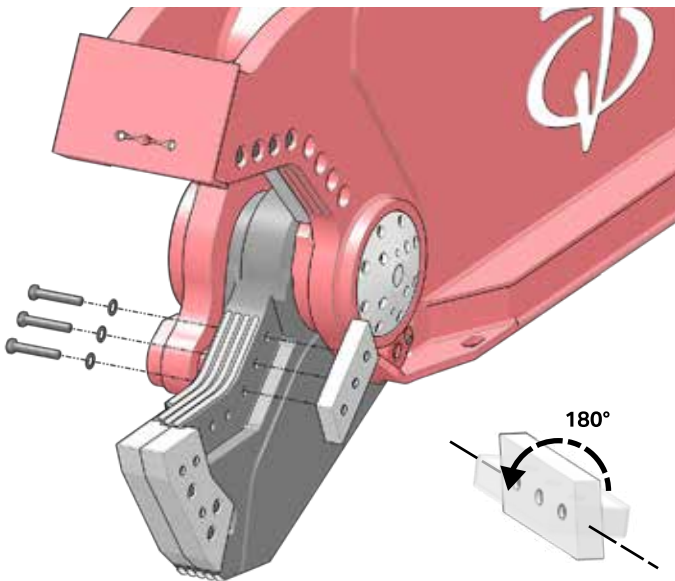

7. Remove the upper primary blade. Rotate the blade, along the long edge, 180° (Roll Rotation).

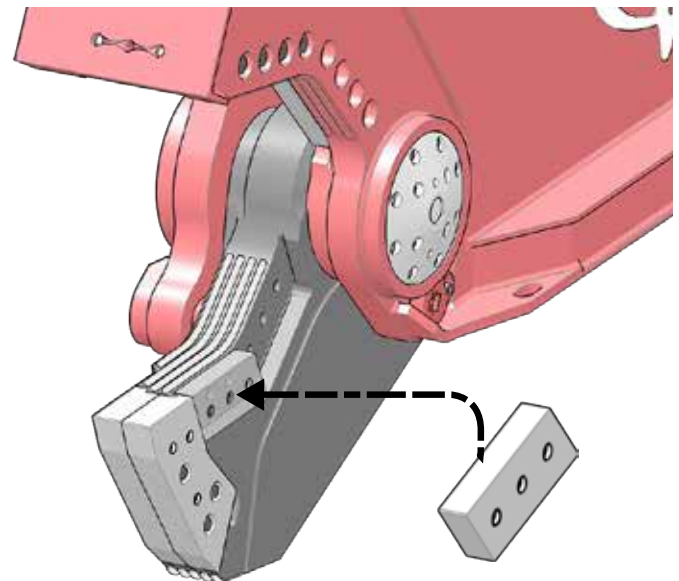

8. Install the rotated blade into the upper secondary blade seat.

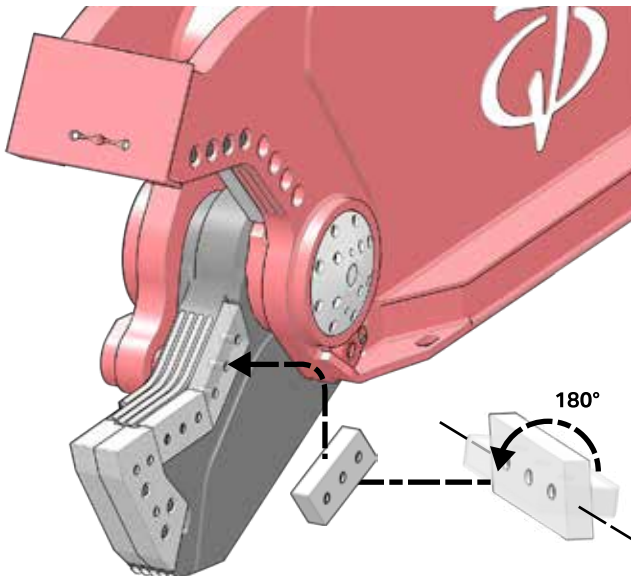

9. Rotate the previously set aside upper primary blade (step 6), along the long edge, 180° (Roll Rotation). Install it into the lower primary blade seat.

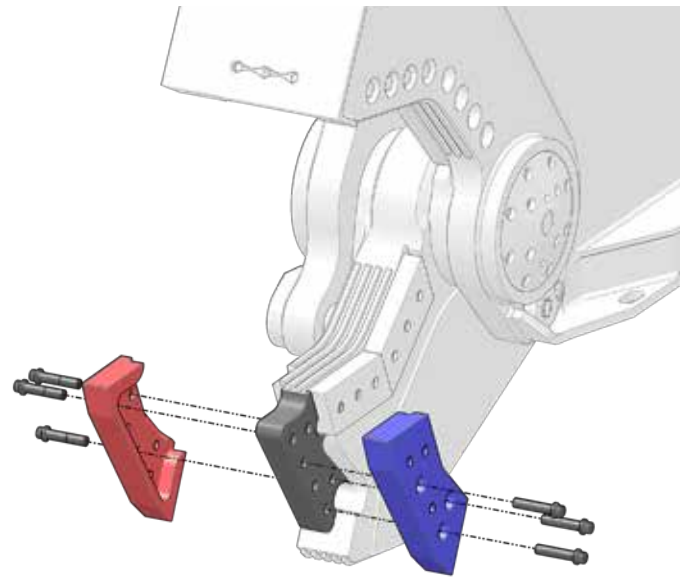

10. With the shear still upside down, remove both piercing tip blades.  
Note: Each piercing tip blade will remain in its blade seat when the bolts are removed. Slide the blades out to remove.

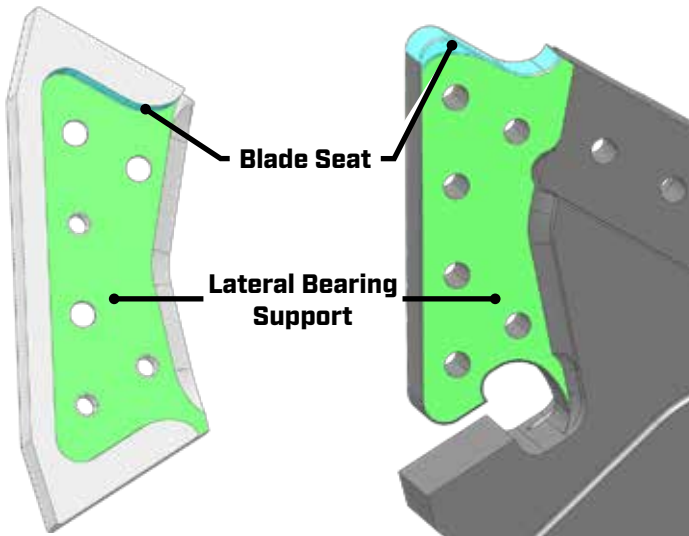

11. The mating surfaces of the piercing tip must be clean to ensure a tight fit. Inspect all mating surfaces on the piercing tip blades and blade seat. Ensure there is no dirt or debris that would prevent a tight fit. Clean all surfaces with a wire brush or a needle scaler, if necessary. Pay particular attention to the surfaces shown.

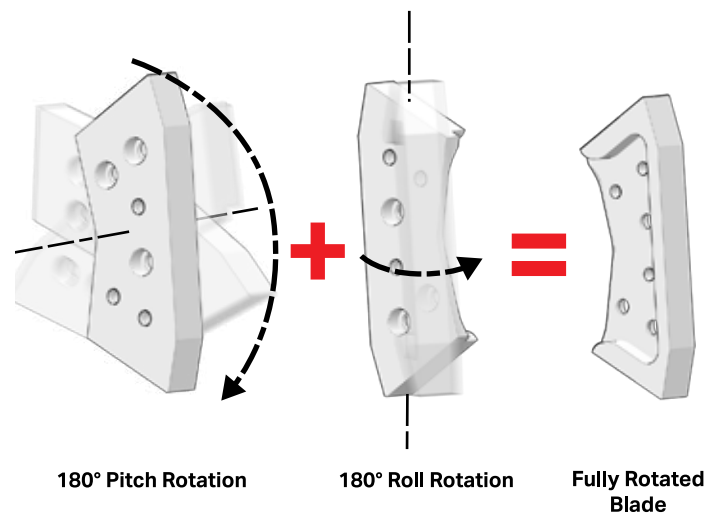

12. Rotate each piercing tip blade 180°, end over end (Pitch Rotation). Then, rotate each blade 180° along the long edge (Roll Rotation). Both piercing tips are now backwards.

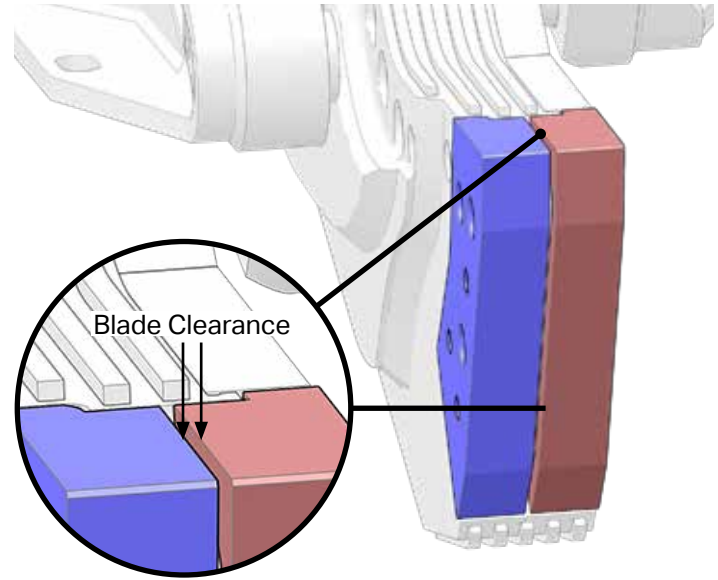
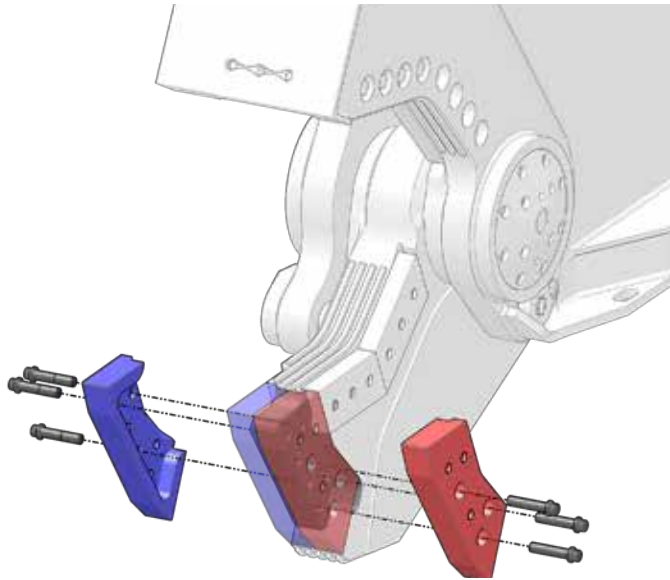

13. Install each piercing tip into the opposite blade seat from which it was removed. Torque bolts to values show in "Inspect / Torque Bolts" on page 25.

14. Measure the clearance between the tip blades. Ensure the clearance is within the specification found in the table below. If there is no clearance, clean the blade and seat as shown in step 11

Piercing Tip Clearance Table	
Model	Clearance
MSD 2250	0.001" - 0.018" (.0254 - .457 mm)
MSD 2500	
MSD 3000	

15. Once installed, shim all cutting blades as shown in "Measuring & Shimming Blade Gaps" on page 28. Then torque the blades as shown in "Inspect / Torque Bolts" on page 25.

### 3<sup>RD</sup> ROTATION

The third blade rotation will be performed exactly the same as the first rotation. After completing the third rotation, order a complete LaBounty blade kit, as all blades will need to be discarded and replaced with new blades during the fourth rotation.

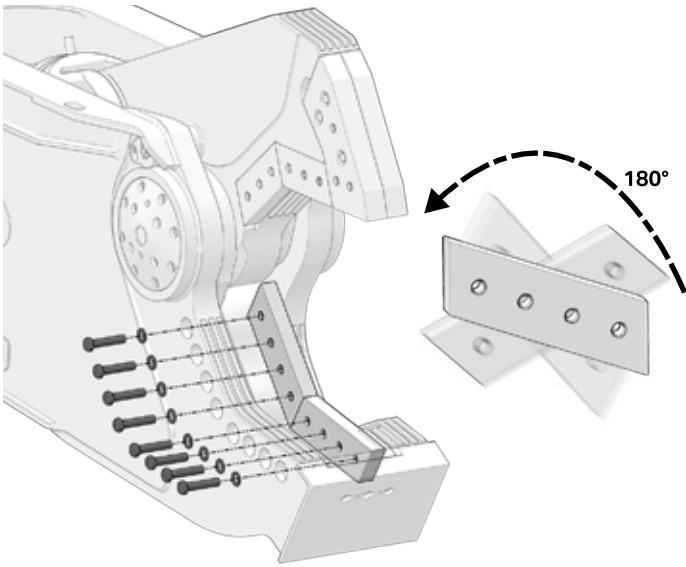

1. Set the shear on the ground, as shown. Remove the lower blades. Rotate each lower blade, end over end, 180° (Pitch Rotation). Return them to their original blade seats.

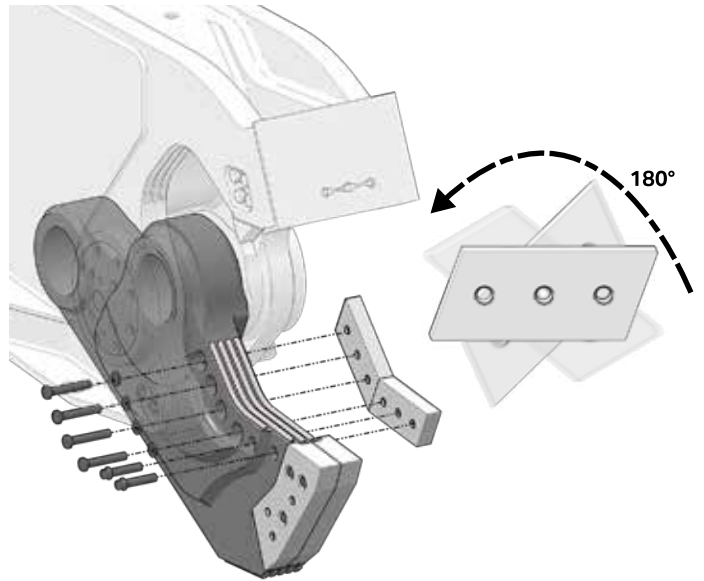

2. Place the shear upside down so that the upper is close to the ground. Rotate each upper blade, end over end, 180° (Pitch Rotation). Return them to their original blade seats. Shim as shown in "Measuring & Shimming Blade Gaps" on page 28.

### 4<sup>TH</sup> ROTATION

All of the cutting surfaces on each blade have now been worn. We must remove and discard the blades, then replace with new blades.

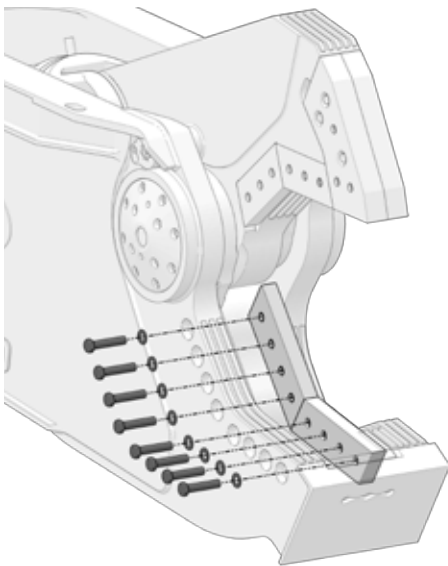

1. Set the shear on the ground, as shown. Remove the lower blades and replace with new blades.

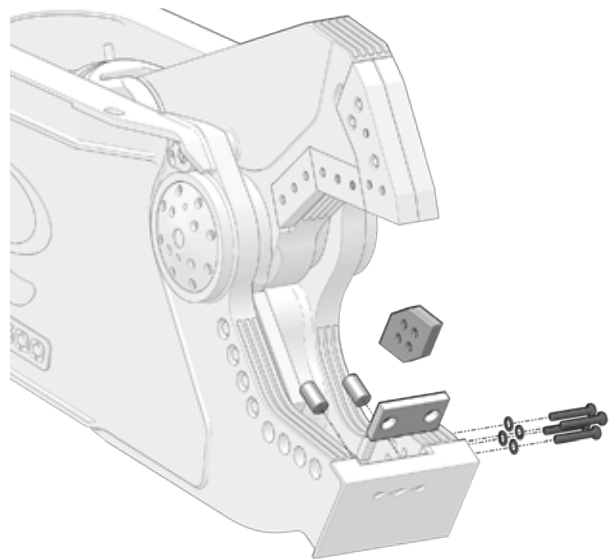

2. Remove the guide and cross blade. Clean the blade seats and replace with new blades.

Note: Do not torque the blade bolts

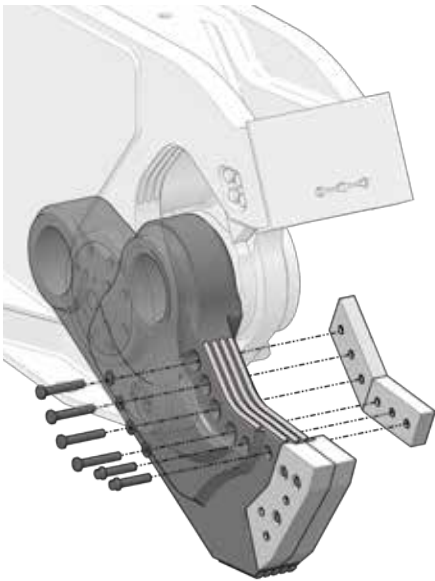

3. Place the shear upside down so that the upper blades are as close to the ground as possible. Remove the upper blades.

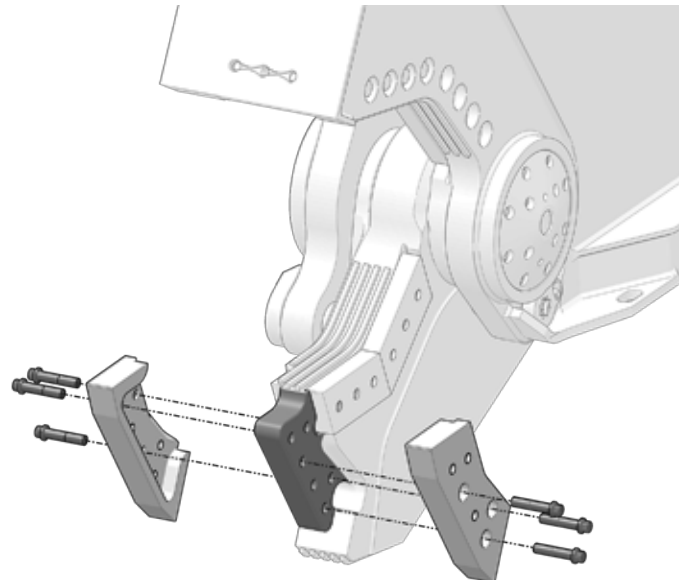

4. With the shear still upside down, remove both piercing tips. Clean the mating surface of the blade seats, as shown in "3rd Rotation" on page 36. Replace with new tips. Replace upper blades at this time.

5. Rotate the attachment so the lower jaw is on the ground. Torque the upper blades and tip as shown in "Inspect / Torque Bolts" on page 25.

## JAW BUILD UP & HARDSURFACING

### NOTICE

Do not use stainless hardsurface rod or other improper build up and hardsurfacing products. Using improper products may result in premature wear or cracking of the base metal.

### CAUTION

Wear personal protection equipment (PPE) at all times. This includes eye protection, hard hat, steel toe shoes, leather gloves and hearing protection that conforms to standards ANSI Z87.1 (Eye and Face Protection), ANSI Z89.1 (Head Protection), ANSI Z41.1 (Foot Protection) and ANSI S12.6 (S3.19) (Hearing Protection).

#### Build Up Recommendations

Choose a build up material that meets the following classifications.

Shielded Metal Arc Welding - Stick Electrodes

- E7018
- E8018-C3

Gas Metal Arc Welding - Solid Wire Electrodes

- ER70S-6

Gas Metal Arc Welding - Flux Cored Electrodes

- E71T-1
- E71T-1M
- E80T1-Ni1
- E80T1-Ni1M

Gas Metal Arc Welding - Metal Powder Cored Electrodes

- E70C-6M
- E80C-Ni1

#### Build Up Instructions

### CAUTION

Wear personal protection equipment (PPE) at all times while welding. Allow only qualified, certified welders to maintain LaBounty products.

1. Disconnect InSite power cable before welding.
2. Thoroughly clean the area to be built up.
3. Preheat the area to 200° F (94° C) to remove moisture.
4. Heat the area to be built up to 400° - 450° F (204° - 233° C).

**Note: Do not exceed 450° F (233° C)**

5. Using AWS E7018 welding rod, make side by side underlayment beads.
6. Relieve stress and remove slag after each pass by peening vigorously with an air operated slag peener.

**Note: Check the temperature often. Maintain 400° - 450° F (204° - 233° C).**

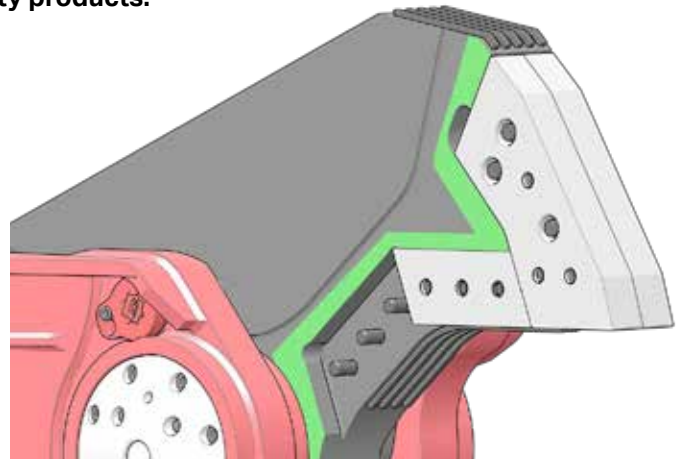

Build Up Example  
**FIGURE 30**

### Upper Jaw

The upper jaw has two areas that must be built up so that they are flush with the upper blades, shown in Figure 31.

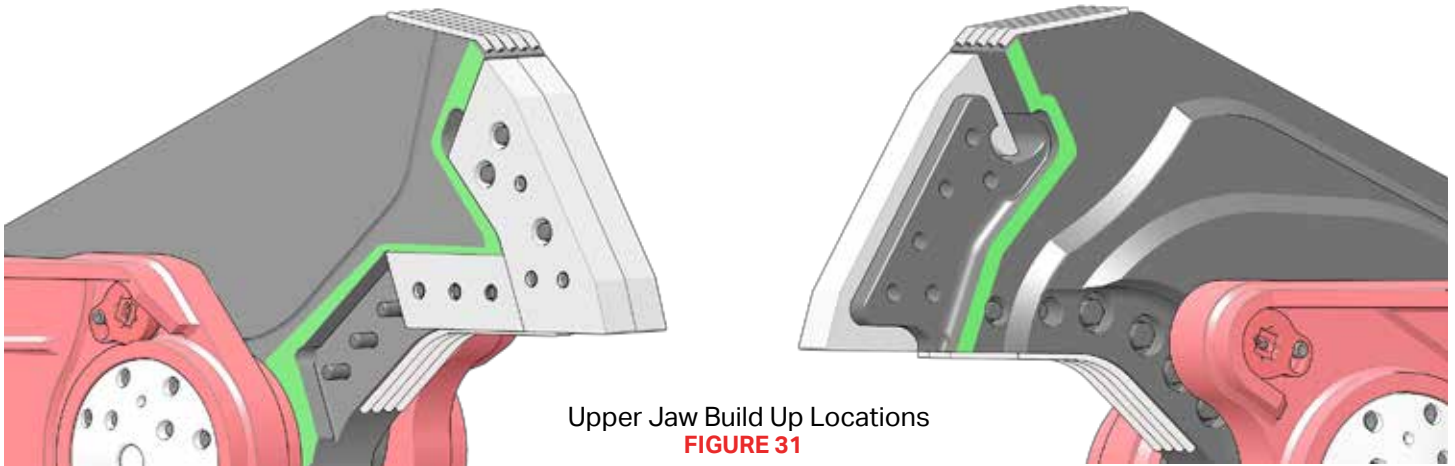

### Lower Jaw

The lower jaw has a number of places that must be built up if worn, as shown in Figure 32. Pay particular attention to the areas around the lower and guide blades, as those areas must be flush with the blade. Use the included guide blade build up template to ensure the build up profile is correct. The lower shear must be grounded when welding to prevent the possibility of electric shock.

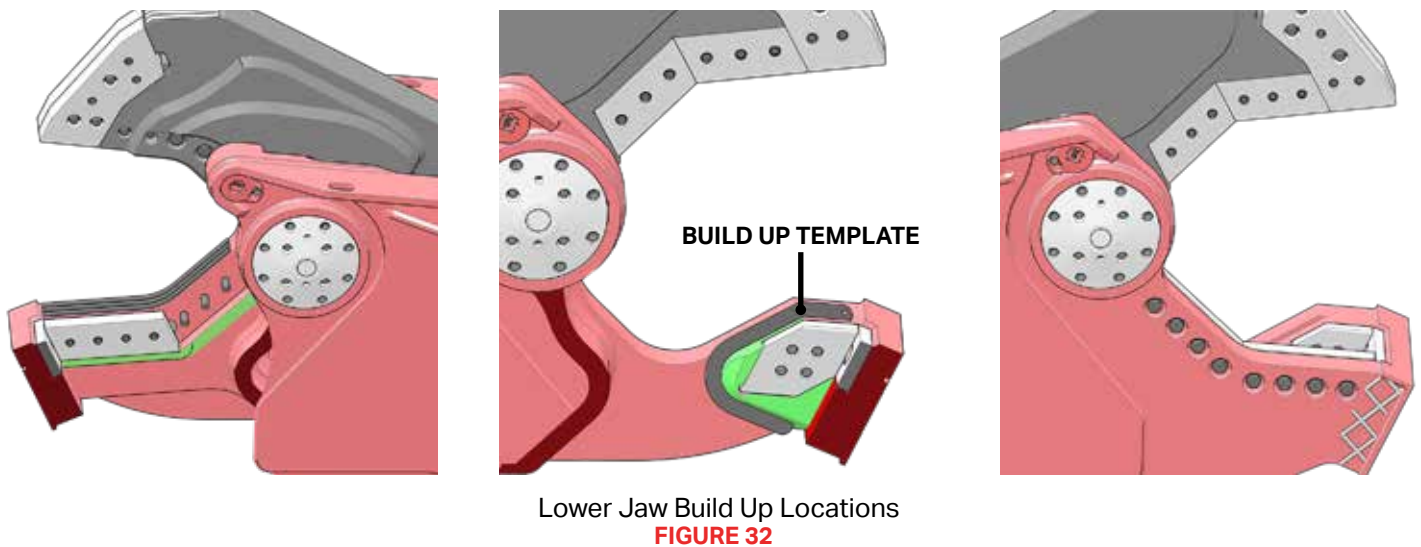

### Hardsurfacing Recommendations

Some attachments have hardsurfacing instead wear bars or plates. Hardsurfacing must be inspected and maintained.

For hardsurfacing, LaBounty recommends;

- Amalloy 814H or equivalent

If you have questions about what hardsurface material to use, contact LaBounty Customer Service at 1-(800) 522-5059.

- Always use hardsurfacing weld material with a chromium content of less than 0.10% and a severe impact-resistance rating, to prevent cracking.
- Apply hardsurfacing directly on top of build up welds. Do not apply hardsurfacing to parent material.
- Remove paint from the area before hardsurfacing.

- When grinding or sanding, wear an approved respirator.
- Remove solvent, paint strippers and other flammable material from the area before hardsurfacing.
- Have a fire extinguisher nearby.
- Do all work in a well ventilated area.
- Disconnect the excavator battery before welding.

### Hardsurface Instructions

#### Build-up

1. Disconnect InSite power cable before welding.
2. Using AWS E7018 welding rod, make side by side underlayment beads.
3. Relieve stress and remove slag after each pass by peening vigorously with an air operated slag peener.

**Note: Check the temperature often. Maintain 300° - 400° F (149° - 205° C) during build-up.**

#### Hardsurface

4. Apply a bead of Amalloy 814H rod directly on top of each underlayment bead.

**Note: Do not apply more than two layers of hard surfacing.**

5. Relieve stress and remove slag after each pass by peening vigorously with an air operated slag peener.
6. Taper the ends of each bead by grinding. Do not undercut the weld.
7. When grinding is complete, peen the area until it is shiny or until the peener cannot dent the weld, about 5-10 minutes.
8. If the temperature has dropped below 400°F (205° C) within 6 inches of the welded area, heat the area up to 400° F (205° C).
9. Wrap the welded area with a heat blanket and allow to cool slowly.

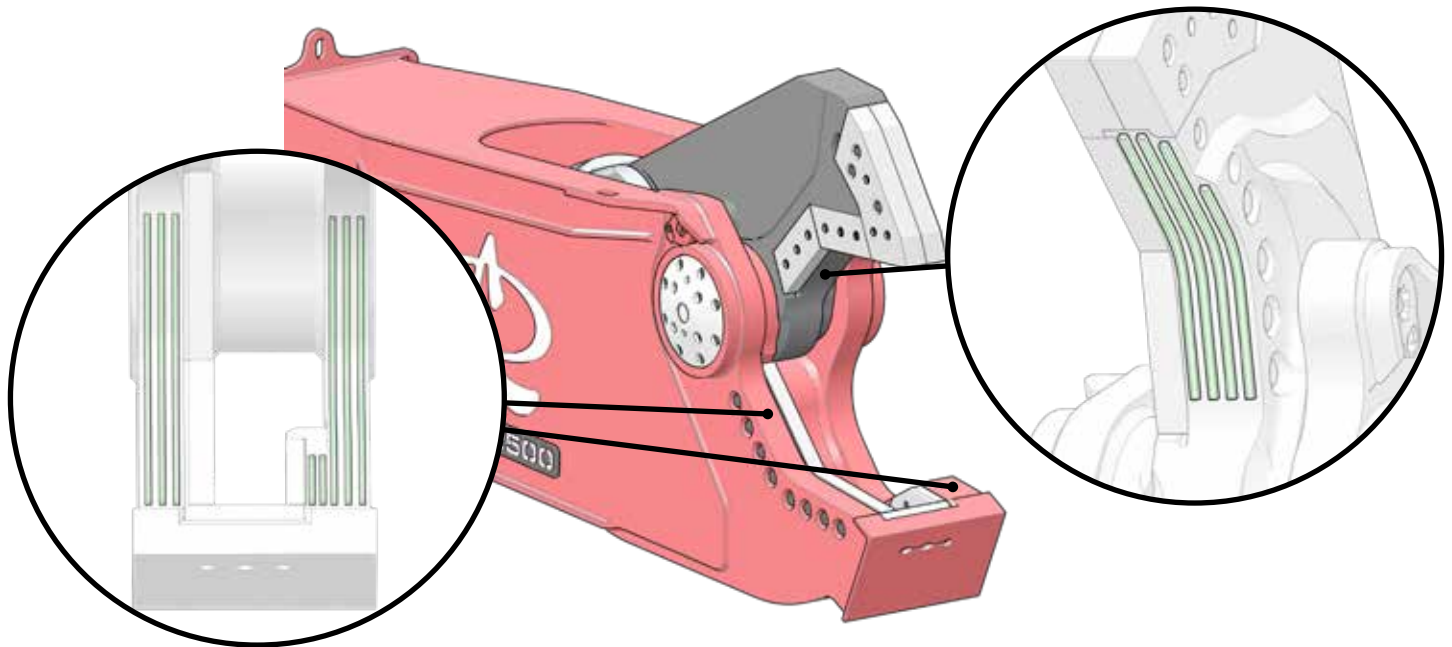

Build Up & Grain Direction  
**FIGURE 33**



## REPLACE WEAR PLATES & BARS

### CAUTION

Wear personal protection equipment (PPE) at all times while welding. Allow only qualified, certified welders to maintain LaBounty products.

#### Inspecting Wear Bars & Wear Plates

1. Measure the thickness of each wear item.
2. Replace when worn down 1/2 of it's original thickness, or as needed.
3. Visually inspect the welds. If the welds show signs of cracks, the wear item must be replaced.
4. Replace wear bars and plates if they are missing.

#### Replace Wear Bars & Wear Plates

1. Preheat the area within 6 inches of the plates to 400° - 450° F (204° - 233° C). Maintain this temperature throughout the process.
2. Using carbon arc gouging, remove the old wear plates or bars from the shear jaw.
3. Grind the surface of the jaw and ensure all weld and carbon residue has been removed and the area is smooth and clean. Build up the area, if necessary.
4. Position the new wear plates or bars on the shear and clamp into position.
5. Weld the wear plates or bars.
6. Stress relieve each pass by peening and grind the welds smooth.
7. Wrap the area with a heat blanket and allow to cool slowly.

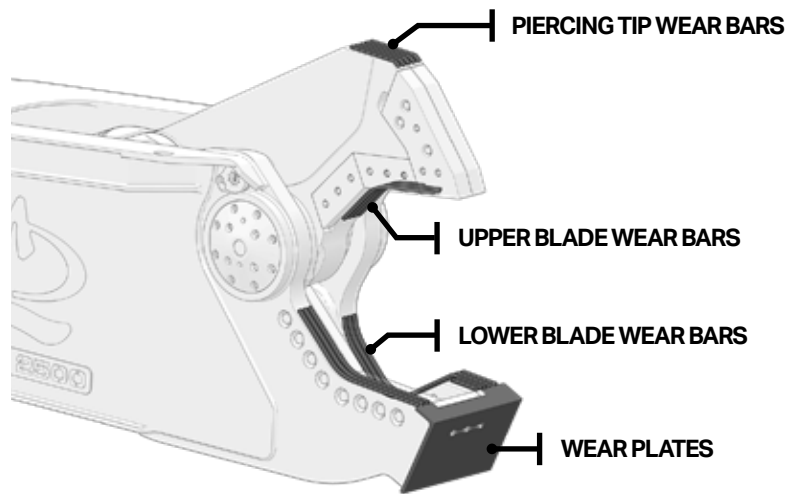

Location of Wear Bars & Plates

FIGURE 34

## SLIDE SCREW ADJUSTMENT

The slide screw keeps the upper jaw in line and cutting properly. There is one screw on each side of the shear and they should be inspected and adjusted every 80 hours.

### DANGER

Do not cycle or move the shear while removing the slide screw by hand. This will result in severe injury.

### WARNING

Keep clear when the shear is in motion. Avoid pinch points, such as the upper shear or the shear cylinder. Severe injury could result.

1. Remove the lock plate bolt and the lock plate.
2. Using a crescent wrench, unscrew the slide screw from the shear body.
3. Inspect the end of the screw that contacts the upper jaw. If the grease channels are worn away, replace the screw.
4. Clean the threads and re-lubricate with 2-EP lithium grease.
5. Apply a layer of grease to where the slide screw comes in contact with the upper shear.
6. Reinsert the slide screw and tighten until the screw begins to touch the upper shear. Reinstall the lock plate.
7. Grease the slide screw, as shown in "Shear Lubrication" on page 23.

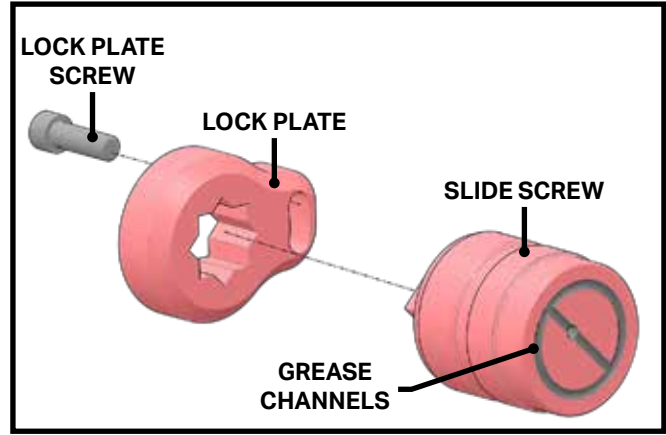
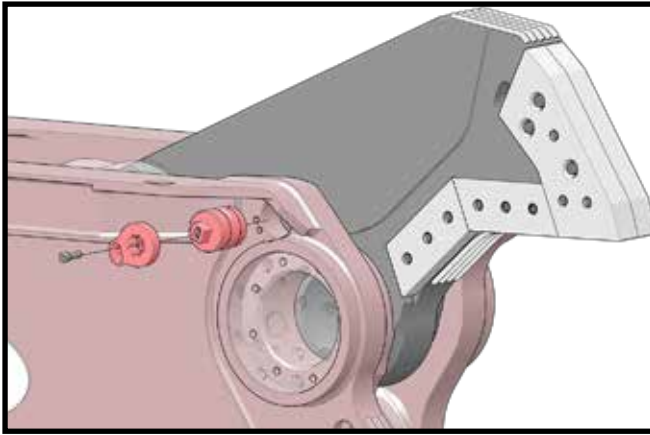

Slide Screw Removal  
**FIGURE 35**

## CHECK THE CYLINDER GAP

1. Fully open the shear jaws.
2. Measure the gap between the rod eye shoulder and the head face, as shown in Figure 36.

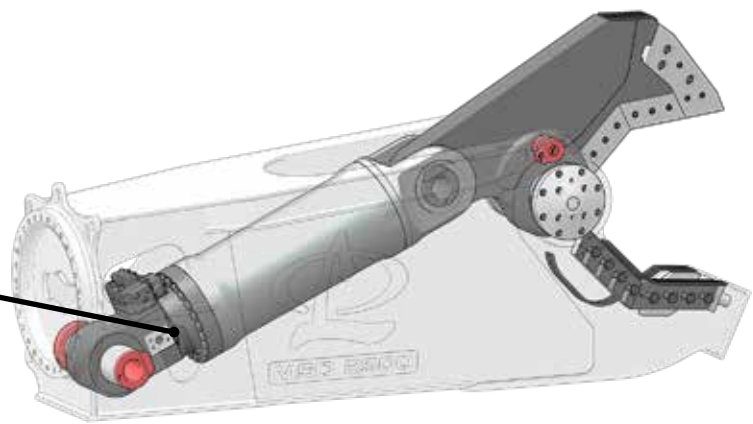
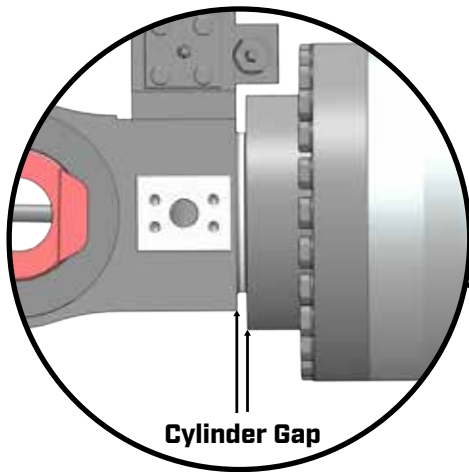

Measuring the Cylinder Gap  
**FIGURE 36**

If the cylinder gap exceeds the value in the "Maximum Cylinder Gap" table, contact the LaBounty Service Department at (218) 834-6901.

Maximum Cylinder Gap Table	
MSD Model	Maximum Cylinder Gap
1500	0.50 inches (13 mm)
2000	1.44 inches (37mm)
2250	0.94 inches (24 mm)
2500	0.56 inches (14 mm)
3000	0.56 inches (14 mm)
4000	0.56 inches (14 mm)
4500	1.00 inches (24.5 mm)

## SPEED VALVE

The speed valve allows the jaws to shift into high speed while closing.

### **WARNING**

Clear all persons and equipment from the area of operation and machine movement. **NEVER** move loads over people or equipment. When viewing the operation of the attachment, maintain a safe distance of at least **75 feet (23 meters)**.

#### Testing the Speed Valve

1. Close the jaws and observe the movement.
2. The jaws closing speed should increase after 1-2 inches of unobstructed movement.
3. If the jaw speed does not increase, adjust the speed valve.

#### Resealing the Poppet

Before adjusting the speed valve, check the poppet valve and reseal if necessary.

### **WARNING**

Relieve pressure before disconnecting hydraulic lines or disassembling hydraulic components. Tighten all connections before reapplying hydraulic pressure. Keep hands and body away from pin holes and nozzles, which can eject fluids under high pressure. Use a piece of cardboard to search for leaks. Escaping fluid under pressure can penetrate the skin and cause serious injury. If ANY fluid is injected into the skin, seek immediate medical attention.

### **WARNING**

**DO NOT** let hydraulic oil get in contact with the skin as it could cause severe burns. Hydraulic oil becomes hot during operation. Wear adequate protective clothing and safety equipment.

### **CAUTION**

Chemicals used on LaBounty Saber Series hydraulic cylinders include hydraulic oil; refer to the excavator operator's manual and have MSDS sheets and proper treatment equipment available.

1. Turn off the excavator and relieve any trapped pressure in the hydraulic system. Lock-out / Tag-out the hydraulic power source.

### **WARNING**

Trapped hydraulic pressure may be present after the base machine is shut off. Extreme caution must be taken when removing hydraulic hoses or lines. Injury or death could result.

2. Slowly unscrew the poppet valve from the pilot valve, in 1/2 turn intervals until the poppet is removed.

Note: Slowly removing the poppet ensures residual hydraulic pressure is relieved from the speed valve.

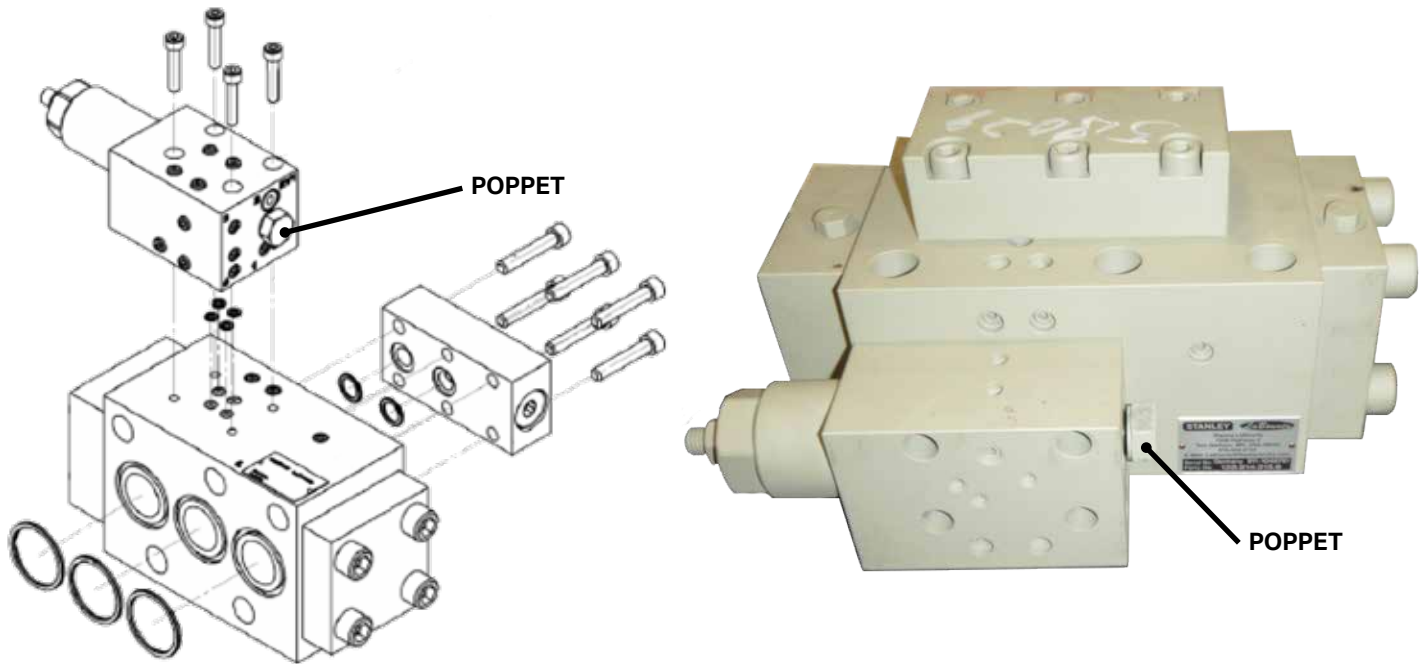

Poppet Location  
FIGURE 37

3. Remove the poppet and the plunger from the pilot valve.

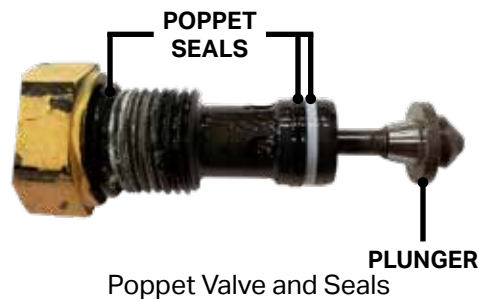

Poppet Valve and Seals  
FIGURE 38

4. Clean and inspect the poppet and plunger to ensure they are not damaged. Ensure the plunger moves freely in the valve. If damaged, replace the poppet valve and seals (part number 513793).
5. Remove and replace the poppet seals (seal kit part number 513794).
6. Install the poppet valve into the pilot valve and torque to 73 ft. lbs. (100 Nm).

### Adjusting the Speed Valve

**Note: Do not adjust the speed valve while the cylinder is moving.**

1. Fully close the shear jaws.
2. Turn the pilot valve adjustment screw all the way counter clockwise.

**Note: Do not turn the pilot valve adjustment screw past the locking nut. This will cause damage to the pilot valve.**

3. Make small adjustments to the pilot valve adjustment screw until the jaws just fail to shift into high speed. This is the minimum setting.
4. Return the shear to the fully open position.
5. From the minimum setting, adjust the pilot valve adjustment screw clockwise half the number of turns required to reach the minimum setting.

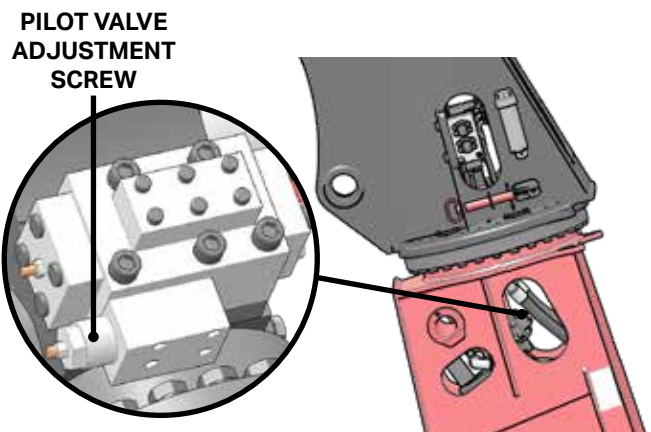

Speed Valve Location  
FIGURE 39

# SPEED VALVE ASSEMBLY ILLUSTRATIONS

## Test Port Locations

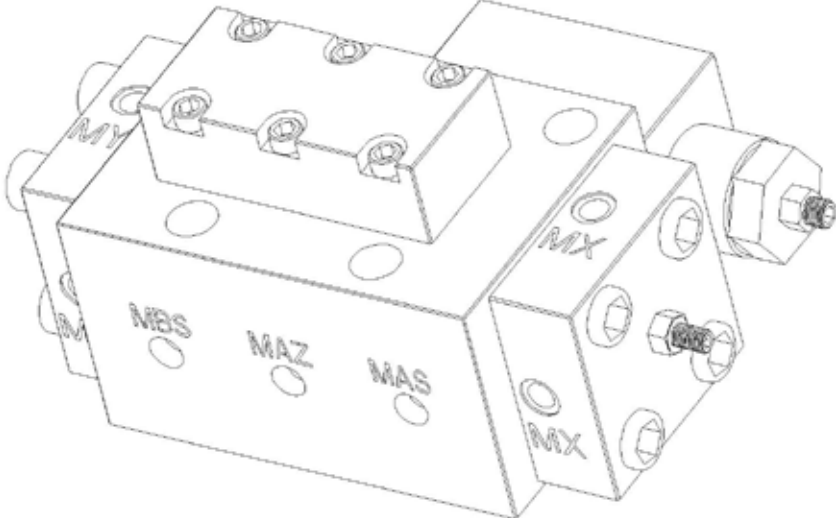

## Main Valve Assembly

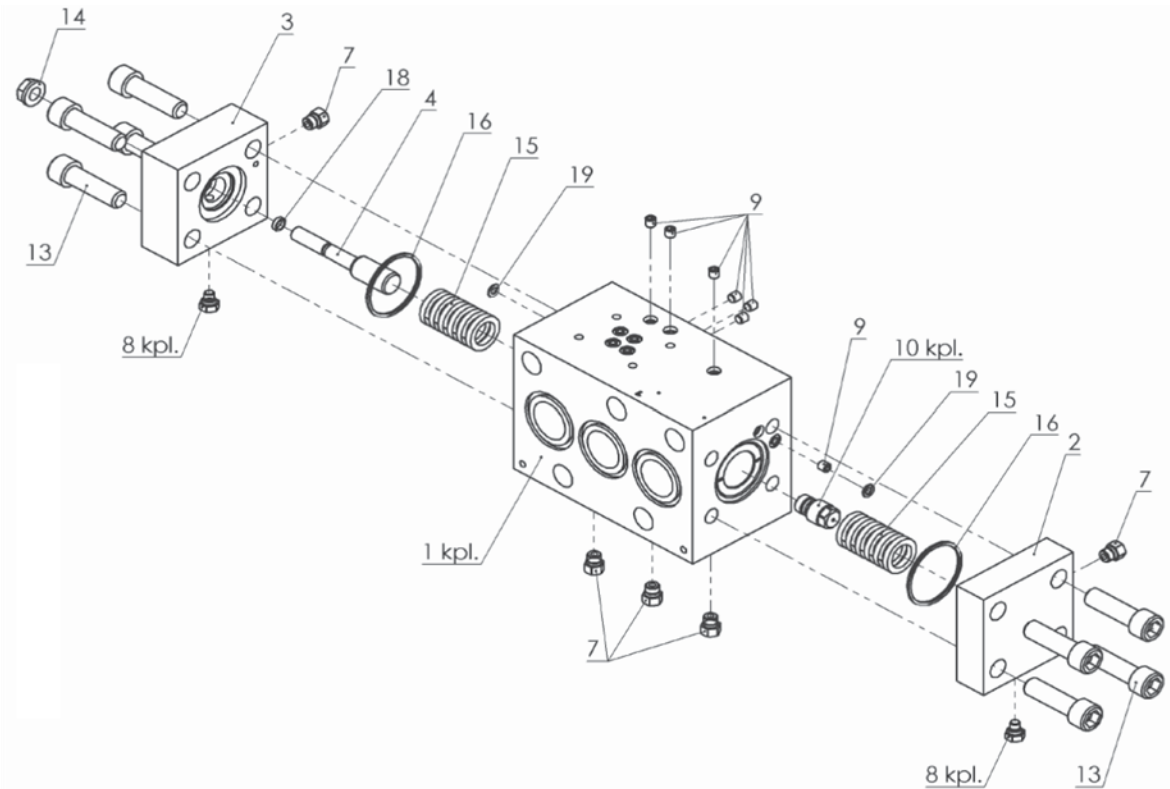

Main Valve Assembly			
Item	Part Number	Qty	Description
1	513876	1	Main Valve Housing
2	511568	1	Valve Cap
3	511569	1	Valve Cap
4	511548	1	End Stop
7	511515	5	Screw Plug Torque to 15 ft. lbs. (20 Nm)
8	513086	2	Screw Plug Torque to 15 ft. lbs. (20 Nm)
9	513087	7	Screw Plug Torque to 7 ft. lbs. (10 Nm)
10	513877	1	Check Valve
13	513878	8	Socket Head Cap screw
14	511504	1	Grommet Nut (Torque to 22 ft. lbs. (30 Nm))
15	511550	2	Spring
16	511503	2	O-Ring Seal
18	511505	1	Thread Seal
19	512347	2	O-Ring Seal

## Pilot Valve Assembly

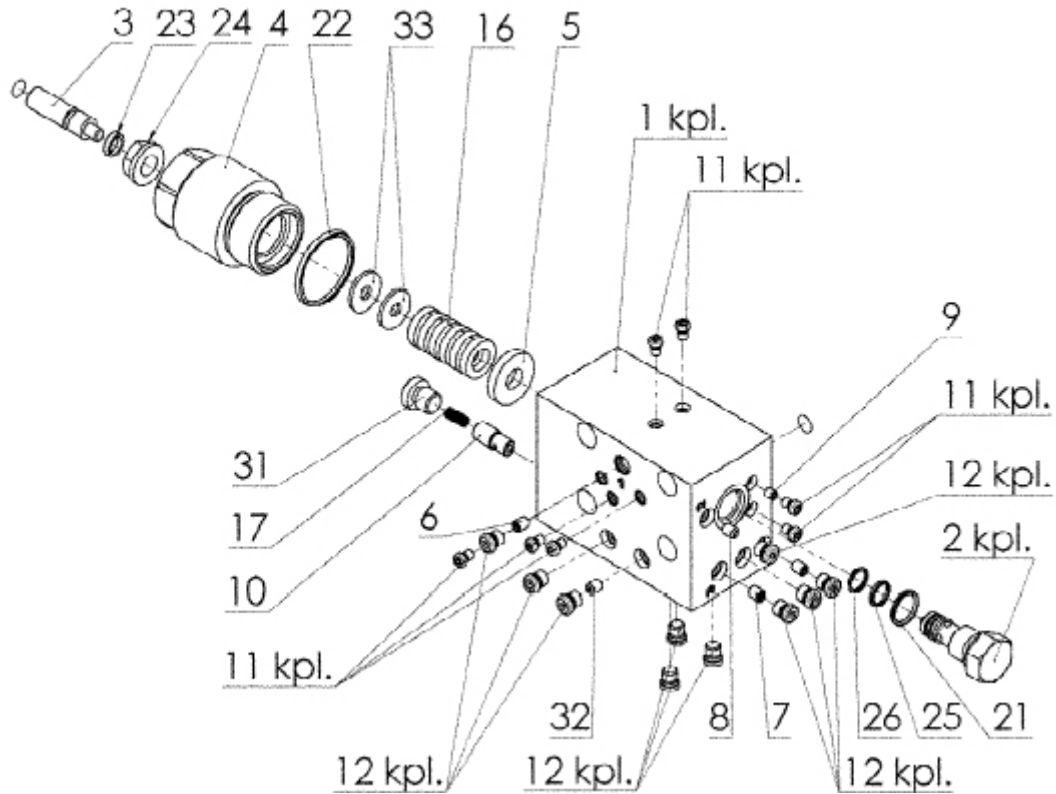

Pilot Valve Assembly			
Item	Part Number	Qty	Description
1	512316	1	Housing
2	512317	1	Valve Seat Torque to 73 ft. lbs. (100 Nm)
3	511555	1	Thread Pin - M12 x 50
4	512318	1	Spring Cap Torque to 162 ft. lbs. (220 Nm)
5	511558	1	Washer - D30 x 5
6	512319	1	Orifice - D1 M6 x 8
7	512320	2	Orifice - D1.2 M6 x 8
8	512321	1	Orifice - D0.5 M6 x 8
9	512322	1	Orifice - D1 M5 x 6
10	511562	1	Valve Seat - D10.1 x 23
11	512323	8	Cap Screw - M5 Torque to 1.5 ft. lbs. (2 Nm)
12	511514	10	Cap Screw - M8 x 1 Torque to 7.5 ft. lbs. (10 Nm)

Pilot Valve Assembly			
Item	Part Number	Qty	Description
16	512324	1	Spring
17	511565	1	Spring
21	511507	1	O-Ring - 15.4 x 2.1
22	512325	1	O-Ring - 36.2 x 3
23	511505	1	Thread Seal Ring - M12
24	511504	1	Seal Nut - M12 Torque to 22 ft. lbs. (30 Nm)
25	511508	1	Quad ring - 10.82 x 1.78
26	511509	1	Support Ring
31	511563	1	Cap Screw - M12 x 1.5 Torque to 18 ft. lbs. (25 Nm)
32	512326	1	Thread Pin - M6 x 8
33	511556	2	Washer - B7.4

## Check Valve Assembly

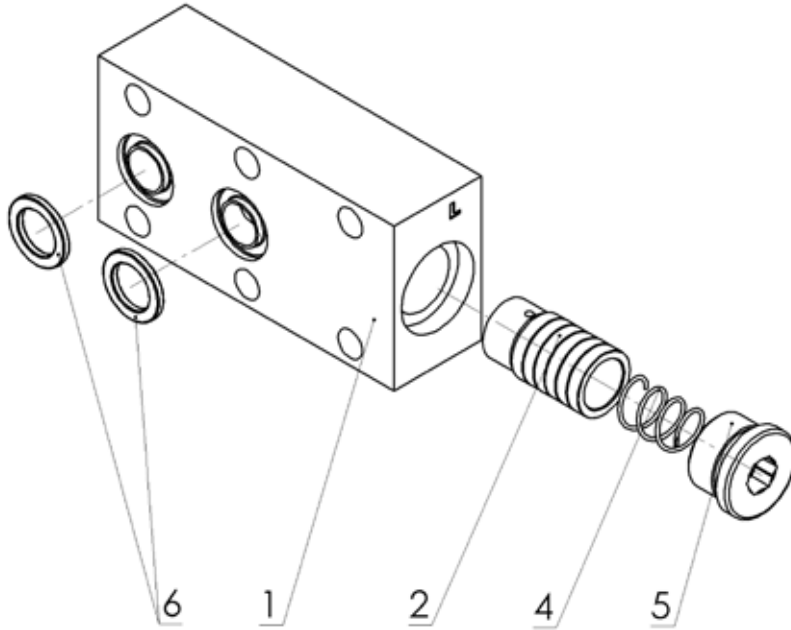

Check Valve Assembly			
Item	Part Number	Qty	Description
1	513875	1	Check Valve Housing
2	511580	1	Plunger
4	511578	1	Spring
5	511579	1	Screw Plug Torque to 103 ft. lbs. (140 Nm)
6	512515	2	O-Ring Seal



# HYDRAULIC SCHEMATICS

## HYDRAULIC SCHEMATIC - STANDARD ROTATING SHEARS

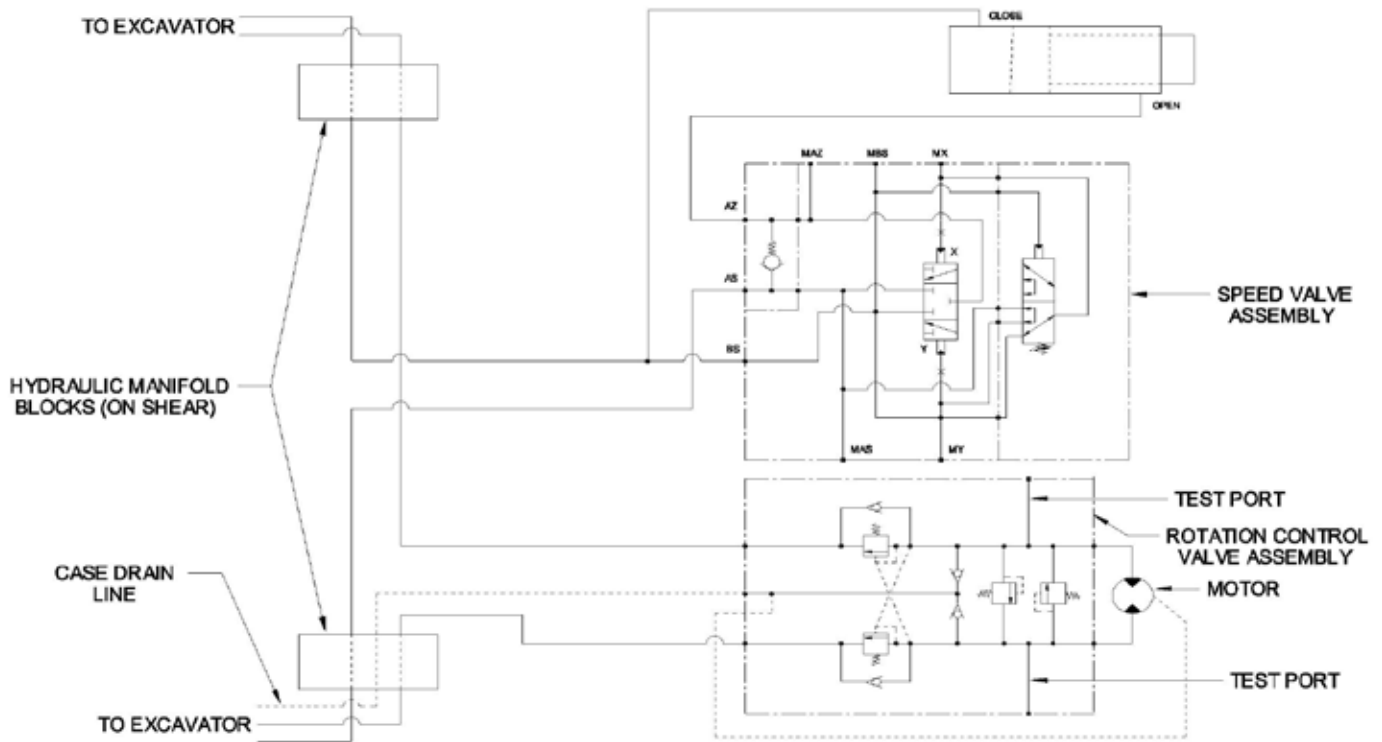

## HYDRAULIC SCHEMATIC - STANDARD NON-ROTATING SHEARS

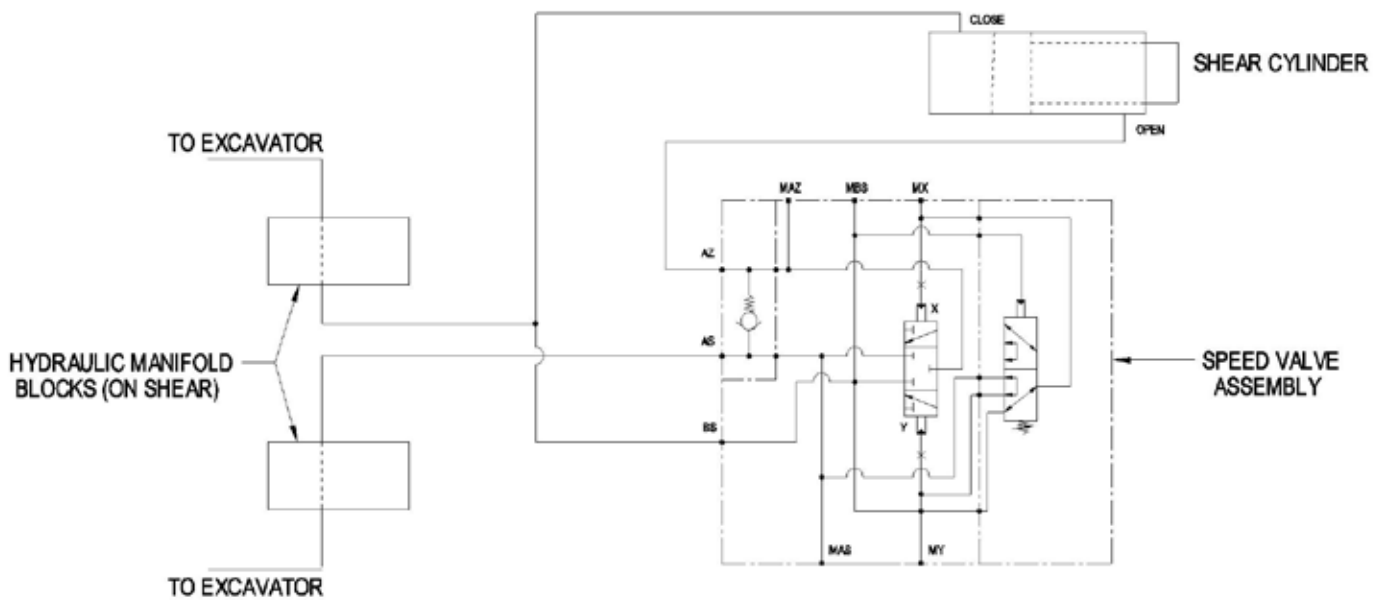







Additional copies of this manual are available by contacting your dealer or the LaBounty parts department, and requesting a CE Operation & Maintenance manual. You must include the attachment model number and serial number.