



MULCHERS FOR  
EXCAVATORS





# M450e

The M450e is a lightweight mulcher for 6-15 ton excavators. The weight is strongly optimized and allows easy handling. In particular, the installed gear motor allows simplified mounting on various excavators as well as rapid changing of carrier units, without installation of additional drain lines.

## Benefits for you:

- + Plug & Mulch
- + Lightweight
- + Simple robust design



### Plug & Mulch

No extra drain line is required. Freewheel and pressure protection are already integrated into the motor.



### Universal connection

Using the adapter plate, the mulcher can be mounted on every position of the excavator arm.



### Stall protection

Counter blades prevent large objects infiltrating and stalling the rotor.



### Wear plates

Can be easily replaced and protect the particularly wear-prone areas in the housing.

TECHNICAL SPECIFICATION	M450E-900	M450E-1090
Working width in [mm]	35 [900]	43 [1100]
Overall width in [mm]	49 [1236]	57 [1441]
Volume flow gpm [l/min]	16-29 [60-110]	16-29 [60-110]
Weight lbs [kg]*	992 [450]	1091 [495]
Tools	20 x UPTs/BCS	24 x BCS

\*Weight is depending on the equipment





The M450e is a hydraulic mulcher for universal use with excavators of 12-20 tons and construction equipment.

**Benefits for you:**

- + Exceptionally simple handling
- + Maximum safety
- + Top shredding quality

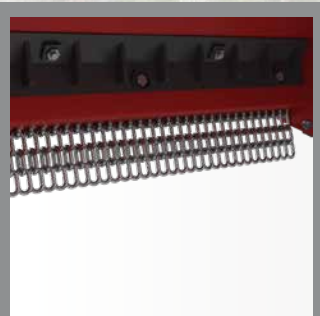

**Stall protection**  
Counter blades prevent large objects infiltrating and stalling the rotor.



**Closed housing**  
The closed housing improves safety by preventing wood and stones from flying out.

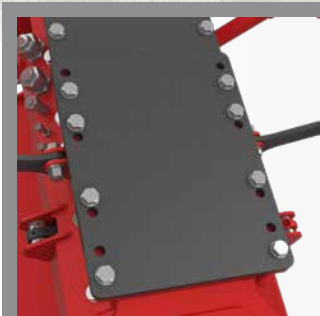

**Flexible mounting**  
A universal plate enables the mulcher to be mounted on a wide variety of carrier vehicles.

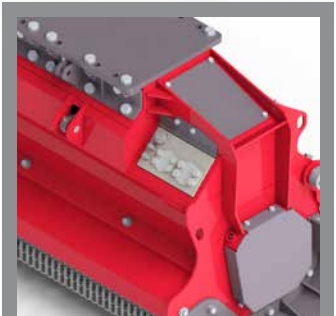

**Variable displacement motor**  
The 80 cc motor with high pressure variable displacement allows individual adjustment with maximum torque.

TECHNICAL SPECIFICATION	M450E-1100
Working width in [mm]	43 [1100]
Overall width in [mm]	54 [1382]
Volume flow gpm [L/min]	21-53 [80-200]
Weight lbs [kg]*	1521 [690]
Tools	30 x HDT / 24 x UPTs / 24 x BCS

\*Weight is depending on the equipment.





# M550e



The M550e is a hydraulic mulcher for universal use with excavators of 18-30 tons and for construction equipment.

#### Benefits for you:

- + High stability and lifetime
- + Reduced power requirement
- + Flexible configurable



#### Coating of the housing

The housing itself with wear resistant liners at critical areas.



#### No hydraulic hoses

No hydraulic hoses at the outside of the housing, which can rip off or get damaged at heavy use.



#### Flexible mounting

A universal plate enables the mulcher to be mounted on a wide variety of carrier vehicles.



#### Two-stage counter blades

Made of highly wear-resistant steel - increases the crushing quality. An additional crushing of the material can be achieved through the counterblades in the flap. (Option)

TECHNICAL SPECIFICATION	M550E-1300
Working width in [mm]	51 [1300]
Overall width in [mm]	66 [1680]
Volume flow gpm [l/min]	21-69 [80-260]
Weight lbs [kg]*	2932 [1330]
Tools	32 x UPTs / 28 x BCS

\*Weight is depending on the equipment





# TECHNICAL DATA

	Working width in [mm]	Overall width in [mm] (x1)	Height in [mm] (y1)	Depth in [mm] (z)	Power class HP	Volume flow gpm [l/min]	Weight* lbs [kg]	Tools
<b>M450e</b>	35 [900]	49 [1236]	26 [656]	27 [678]	max. 90	16-29 [60-110]	992 [450]	20 x UPTs/BCS
	43 [1100]	57 [1441]	26 [656]	27 [678]	max. 90	16-29 [60-110]	1091 [495]	24 x BCS
	43 [1100]	54 [1382]	36 [910]	32 [816]	60-120	21-53 [80-200]	1521 [690]	30 x HDT / 24 x UPTs / 24 x BCS
<b>M550e</b>	51 [1300]	66 [1680]	39 [979]	46 [1161]	max. 250	21-69 [80-260]	2932 [1330]	32 x UPTs / 28 x BCS

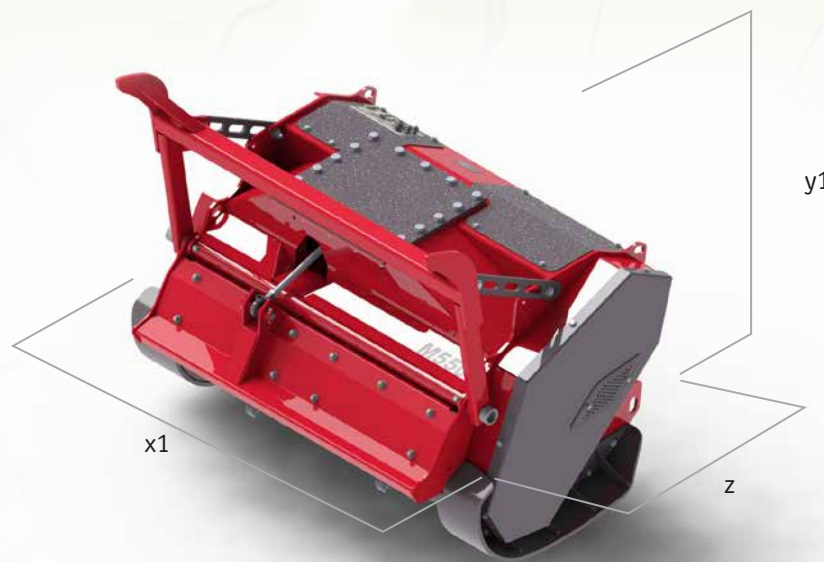

\*Weight is depending on the equipment

# TOOLS

## BCS ROTOR SYSTEM

- + High cutting performance
- + Easy load handling while mulching



BCS02

BCS03

## UPTS ROTOR SYSTEM

- + Best penetration capabilities
- + Reduced fuel consumption



UPTs02

UPTs04

UPTs07

UPTs08

## HDT ROTOR SYSTEM

- + High flexibility
- + First-class mulch quality



HDT01

HDT02

HDT03

HDT04



Other sales and service sites can be found on [www.prinoth.com](http://www.prinoth.com)

PRINOTH GmbH  
Im Branden 15  
88634 Herdwangen  
GERMANY  
Phone: +49 7557 9212 0  
[prinoth.germany@prinoth.com](mailto:prinoth.germany@prinoth.com)

PRINOTH AG  
Brennerstraße 34  
39049 Sterzing (BZ)  
ITALY  
Phone: +39 0472 72 26 22  
[prinoth@prinoth.com](mailto:prinoth@prinoth.com)

PRINOTH Ltd.  
1001, J.-A. Bombardier Street  
Granby Qc J2J 1E9  
CANADA  
Phone: +1 450 776 3600  
[sales.na@prinoth.com](mailto:sales.na@prinoth.com)