

SY75C Excavator



KEY FEATURES

- Engine: Isuzu AU-4LE2X, Tier 4i
- Minimum swing radius for tight job sites
- Auto-deceleration system maximizes efficiency while reducing fuel consumption
- New design offers increased speed while maintaining smooth hydraulic control
- Standard features include two-way auxiliary hydraulics, backfill blade, and a pattern-control change valve to increase productivity and versatility

SPECIFICATIONS

Net Power

54.3 hp / 40.5 kW

Operating Weight

16,050 lb / 7280 kg

Dig Depth

14' 6" / 4450 mm

Bucket Breakout

11,465 lbf / 51 kN

SANY America Inc.

318 Cooper Circle, Peachtree City, GA 30269

Tel: 678-251-2810 | Fax: 770-632-7820

www.sanyamerica.com



**SANY
AMERICA**

SY75C Dimensions & Specifications

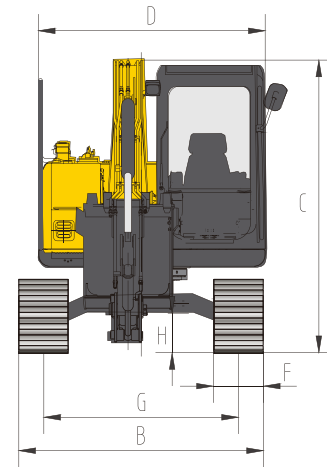
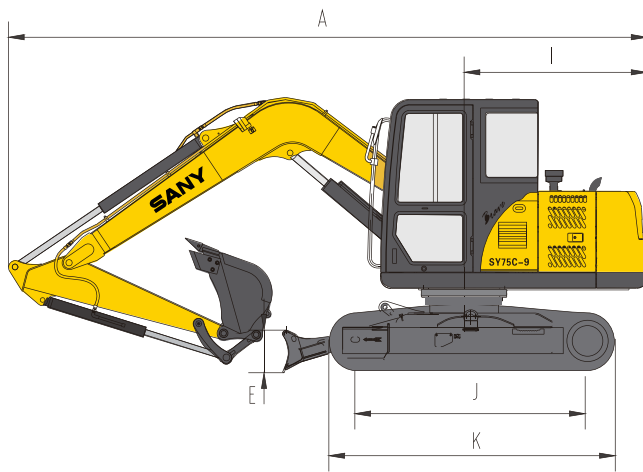

Overall Dimensions

	U.S. (ft - in)	Metric (mm)
A Transport Length	20'	6095
B Transport Width	7' 3"	2220
C Transport Height	8' 7"	2610
D Upper Width	6' 8"	2040
E Blade Plate Height	1' 4"	405
F Std Track Shoe Width	1' 6"	450
G Track Gauge	5' 9"	1750
H Minimum Ground Clearance	1' 3"	380
I Tail Swing Radius	5' 11"	1800
J Length Center Idler to Center Sprocket	7' 2"	2195
K Track Length	9' 3"	2815
Boom Length	12' 3"	3720
Std Arm Length	6' 9"	2050

Machine Parameters

	U.S.	Metric
Operating Weight	16,050 lb	7280 kg
Net Power	54.3 hp	40.5 kW
Engine Max Torque	154.9 lbf / 1500 rpm	210 Nm / 1500 rpm
Swing Speed	10 rpm	10 rpm
Travel Speed	2.7 / 1.5 mph	4.4 / 2.4 km/h
Draw Bar Pull (Tractive Effort)	12,770 lbf	56.8 kN
Max Arm Digging Force	6,744 lbf	30 kN
Max Bucket Digging Force	11,465 lbf	51 kN
Number of Upper Rollers	1	1
Number of Lower Rollers	5	5
Fuel Tank Capacity	39.6 gal	150 liter
Hydraulic Tank Capacity	31.7 gal	120 liter
Cooling System Capacity	3.2 gal	12 liter
Engine Oil Capacity	2.6 gal	10 liter
Ground Pressure (450 mm Shoes)	4.8 psi	33 kPa

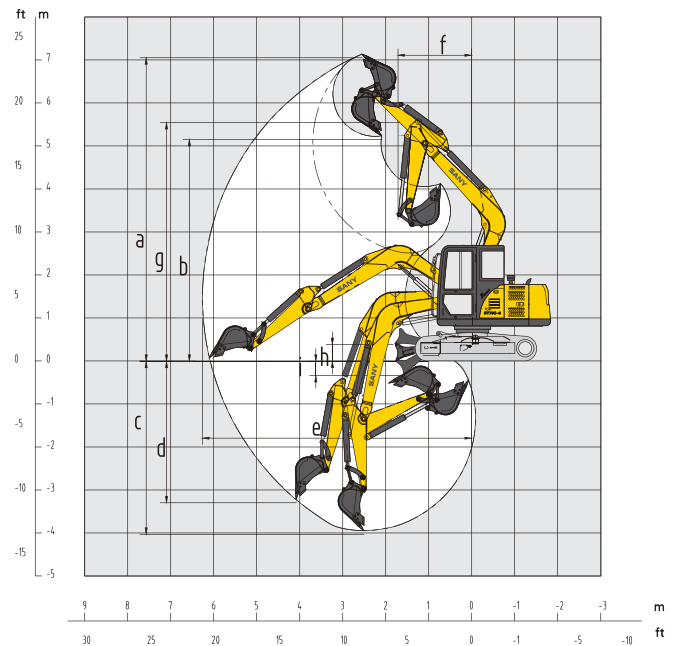

Operating Range

	U.S. (ft - in)	Metric (mm)
a Max Digging Height	24' 4"	7420
b Max Dumping Height	18' 0"	5495
c Max Digging Depth	14' 7"	4450
d Max Vertical Wall Digging Depth	12' 7"	3840
e Max Digging Reach	21' 11"	6660
f Min Swing Radius	5' 8"	1720
g Max Height at Minimum Swing Radius	18' 2"	5550